

# PHILIPS

Data handbook



Electronic  
components  
and materials

## Electron tubes

Part 3 January 1975

Special Quality tubes

Miscellaneous devices



# ELECTRON TUBES

Part 3

January 1975

---

Special Quality tubes

---

Miscellaneous devices

---

Index

---



**Argentina**

FAPESA I.y.C.  
Av. Crovara 2550  
Tel. 652-7438/7478  
BUENOS AIRES

**Australia**

Philips Industries Ltd.  
Elcoma Division  
67-71 Mars Road  
Tel. 42 1261  
LANE COVE, 2066, N.S.W.

**Austria**

Österreichische Philips  
Bauelemente Industrie G.m.b.H.  
Zieglergasse 6  
Tel. 93 26 22  
A-1072 VIENNA

**Belgium**

M.B.L.F.  
80, rue des Deux Gares  
Tel. 23 00 00  
B-1070 BRUSSELS

**Brazil**

IBRAPH: S.A.  
Av. Paulista 2073-S/Loja  
Tel. 278-1111  
SAO PAULO, SP.

**Canada**

Philips Electron Devices  
116 Vanderhoof Ave.  
Tel. 425-5161  
TORONTO 17, Ontario

**Chile**

Philips Chilena S.A.  
Av. Santa Maria 0760  
Tel. 39-40 01  
SANTIAGO

**Colombia**

SADAPE S.A.  
Calle 19, No. 5-51  
Tel. 422-175  
BOGOTA D.E. 1

**Denmark**

Miniwatt A/S  
Emdrupvej 115A  
Tel. (01) 69 16 22  
DK-2400 KØBENHAVN NV

**Finland**

Oy Philips Ab  
Elcoma Division  
Kaivokatu 8  
Tel. 1 72 71  
SF-00100 HELSINKI 10

**France**

R.T.C.  
La Radiotechnique-Compelec  
130 Avenue Ledru Rollin  
Tel. 357-69-30  
F-75540 PARIS 11

**Germany**

Valvo G.m.b.H.  
Valvo Haus  
Burchardstrasse 19  
Tel. (040) 3296-1  
D-2 HAMBURG 1

**Greece**

Philips S.A. Hellónique  
Elcoma Division  
52, Av. Syngrou  
Tel. 915 311  
ATHENS

**Hong Kong**

Philips Hong Kong Ltd.  
Components Dept.  
11th FL., Din Wai Ind. Bldg  
49 Hoi Yuen Rd  
Tel. K-42 72 32  
KWUNTONG

**India**

INBELEC Div. of  
Philips India Ltd.  
Band Box House  
254-D, Dr. Annie Besant Rd  
Tel. 457 311-5  
Prabhadevi, BOMBAY-25-DD

**Indonesia**

P.T. Philips-Ralin Electronics  
Elcoma Division  
Djalan Gadjah Mada 18  
Tel. 44 163  
DJAKARTA

**Ireland**

Philips Electrical (Ireland) Ltd.  
Newstead, Clonskeagh  
Tel. 69 33 55  
DUBLIN 14

**Italy**

Philips S.p.A.  
Sezione Elcoma  
Piazza IV Novembre 3  
Tel. 69 94  
I-20124 MILANO

**Japan**

NIHON PHILIPS  
32nd Fl., World Trade Center Bldg.  
5, 3-chome, Shiba Hamamatsu-cho  
Minato-ku  
Tel. (435) 5204-5  
TOKYO

**Mexico**

Electrónica S.A. de C.V.  
Varsovia No. 36  
Tel. 5-33-11-80  
MEXICO 6, D.F.

**Netherlands**

Philips Nederland B.V.  
Afd. Flonco  
Boschdijk 525  
Tel. (040) 79 33 33  
NL-4510 EINDHOVEN

**New Zealand**

EDAC Ltd.  
70-72 Kingsford Smith Street  
Tel. 873 159  
WELLINGTON

**Norway**

Electronica A.S.  
Middelthunsgate 27  
Tel. 46 39 70  
OSLO 3

**Peru**

CADESA  
Jr. Ilo, No. 216  
Apartado 10132  
Tel. 27 73 17  
LIMA

**Philippines**

EDAC  
Philips Industrial Dev. Inc.  
2246 Pasong Tamo Street  
Tel. 88 94 53 (to 56)  
MAKATI-RIZAL

**Portugal**

Philips Portuguesa S.A.R.L.  
Av. Eng. Duharte Pacheco 6  
Tel. 68 31 21  
LISBOA 1

**Singapore**

Philips Singapore Private Ltd.  
Elcoma Div.  
P.O. Box 340, Toa Payoh Central P.O.,  
Lorong 1, Toa Payoh  
Tel. 53 88 11  
SINGAPORE 12

**South Africa**

EDAC (Pty.) Ltd.  
South Park Lane  
New Doornfontein  
Tel. 24/6701-2  
JOHANNESBURG

**Spain**

COPRESA S.A.  
Balmes 22  
Tel. 329 63 12  
BARCELONA 7

**Sweden**

ELCOMA A.B.  
Lidingövägen 50  
Tel. 08/67 97 80  
S-10 250 STOCKHOLM 27

**Switzerland**

Philips A.G.  
Edenstrasse 20  
Tel. 01/44 22 11  
CH-8027 ZUERICH

**Taiwan**

Philips Taiwan Ltd.  
3rd FL., San Min Building  
57-1, Chung Shan N. Rd, Section 2  
P.O. Box 22978  
Tel. 553101-5  
TAIPEI

**Turkey**

Türk Philips Ticaret A.S.  
EMET Department  
Gümissuyu Cad. 78-80  
Tel. 45.32.50  
Beyoğlu, ISTANBUL

**United Kingdom**

Mullard Ltd.  
Mullard House  
Torrington Place  
Tel. 01-580 6633  
LONDON WC1E 7HD

**United States**

North American Philips  
Electronic Component Corp.  
230, Duffy Avenue  
Tel. (516)931-6200  
HICKSVILLE, N.Y. 11802

**Uruguay**

Luziflectron S.A.  
Rondeau 1567, piso 5  
Tel. 9 43 21  
MONTEVIDEO

**Venezuela**

C.A. Philips Venezolana  
Elcoma Dept.  
Av. Principal de los Ruices  
Edif. Centro Colgate, Apdo 1167  
Tel. 36.05.11  
CARACAS



# DATA HANDBOOK SYSTEM

Our Data Handbook System is a comprehensive source of information on electronic components, subassemblies and materials; it is made up of three series of handbooks each comprising several parts.

**ELECTRON TUBES**

**BLUE**

**SEMICONDUCTORS AND INTEGRATED CIRCUITS**

**RED**

**COMPONENTS AND MATERIALS**

**GREEN**

The several parts contain all pertinent data available at the time of publication, and each is revised and reissued periodically.

Where ratings or specifications differ from those published in the preceding edition they are pointed out by arrows. Where application information is given it is advisory and does not form part of the product specification.

If you need confirmation that the published data about any of our products are the latest available, please contact our representative. He is at your service and will be glad to answer your inquiries.

---

This information is furnished for guidance, and with no guarantee as to its accuracy or completeness; its publication conveys no licence under any patent or other right, nor does the publisher assume liability for any consequence of its use; specifications and availability of goods mentioned in it are subject to change without notice; it is not to be reproduced in any way, in whole or in part without the written consent of the publisher.

---

# ELECTRON TUBES (BLUE SERIES)

This series consists of the following parts, issued on the dates indicated.

- |                |  |                                  |
|----------------|--|----------------------------------|
| <b>Part 1a</b> | <b>Transmitting tubes for communications</b> | <b>April 1973</b>                |
|                | <b>and Tubes for r.f. heating</b>            | <b>Types PB2/500 ÷ TBW15/125</b> |
| <b>Part 1b</b> | <b>Transmitting tubes for communication</b>  | <b>August 1974</b>               |
|                | <b>Tubes for r.f. heating</b>                |                                  |
|                | <b>Amplifier circuit assemblies</b>          |                                  |
| <b>Part 2</b>  | <b>Microwave products</b>                    | <b>October 1974</b>              |
|                | Communication magnetrons                     | Diodes                           |
|                | Magnetrons for micro-wave heating            | Triodes                          |
|                | Klystrons                                    | T-R Switches                     |
|                | Traveling-wave tubes                         | Microwave Semiconductor devices  |
|                |  | Isolators Circulators            |
| <b>Part 3</b>  | <b>Special Quality tubes;</b>                | <b>January 1974</b>              |
|                | <b>Miscellaneous devices</b>                 |                                  |
| <b>Part 4</b>  | <b>Receiving tubes</b>                       | <b>September 1973</b>            |
| <b>Part 5a</b> | <b>Cathode-ray tubes</b>                     | <b>November 1973</b>             |
| <b>Part 5b</b> | <b>Camera tubes; Image intensifier tubes</b> | <b>December 1973</b>             |
| <b>Part 6</b>  | <b>Products for nuclear technology</b>       | <b>January 1974</b>              |
|                | <b>Photodiodes</b>                           |                                  |
|                | Photomultiplier tubes                        | Neutron tubes                    |
|                | Channel electron multipliers                 | Photo diodes                     |
|                | Geiger-Mueller tubes                         |                                  |
| <b>Part 7</b>  | <b>Gas-filled tubes</b>                      | <b>February 1974</b>             |
|                | Voltage stabilizing and reference tubes      | Thyratrons                       |
|                | Counter, selector, and indicator tubes       | Ignitrons                        |
|                | Trigger tubes                                | Industrial rectifying tubes      |
|                | Switching diodes                             | High-voltage rectifying tubes    |
| <b>Part 8</b>  | <b>T.V. Picture tubes</b>                    | <b>May 1974</b>                  |

# COMPONENTS AND MATERIALS (GREEN SERIES)

These series consists of the following parts, issued on the dates indicated.

## Part 1 Functional units, Input/output devices,

### Electro-mechanical components, Peripheral devices

June 1974

High noise immunity logic FZ/30-Series  
Circuit blocks 40-Series and CSA70  
Counter modules 50-Series  
Norbits 60-Series, 61-Series

Circuit blocks 90-Series  
Input/output devices  
Electro-mechanical components  
Peripheral devices

## Part 2a Resistors

Fixed resistors  
Variable resistors  
Voltage dependent resistors (VDR)  
Light dependent resistors (LDR)

September 1974

Negative temperature coefficient  
thermistors (NTC)  
Positive temperature coefficient  
thermistors (PTC)  
Test switches

## Part 2b Capacitors

Electrolytic capacitors  
Paper capacitors and film capacitors

December 1974

Ceramic capacitors  
Variable capacitors

## Part 3 Radio, Audio, Television

FM tuners  
Loudspeakers  
Television tuners, aerial input  
assemblies

June 1973

Components for black and white TV  
Components for colour television  
Deflection assemblies for camera  
tubes

## Part 4a Soft ferrites

Ferrites for radio, audio and television  
Small coils

October 1973

Ferroxcube potcores and square cores  
Ferroxcube transformer cores

## Part 4b Piezoelectric ceramics, Permanent magnet materials

October 1973

## Part 5 Ferrite core memory products

Ferroxcube memory cores  
Matrix planes and stacks

January 1974

Core memory systems

## Part 6 Electric motors and accessories

Small synchronous motors  
Stepper motors

March 1974

Miniature direct current motors

## Part 7 Circuit blocks

Circuit blocks 100 kHz-Series  
Circuit blocks-1-Series  
Circuit blocks 10-Series

September 1971

Circuit blocks for ferrite core  
memory drive

# SEMICONDUCTORS AND INTEGRATED CIRCUITS (RED SERIES)

This series consists of the following parts, issued on the dates indicated.

## Part 1a Rectifier diodes and thyristors

June 1974

Rectifier diodes  
Voltage regulator diodes ( $> 1,5$  W)  
Transient suppressor diodes

Thyristors, diacs, triacs  
Rectifier stacks

## Part 1b Diodes

July 1974

Small signal germanium diodes  
Small signal silicon diodes  
Special diodes

Voltage regulator diodes ( $< 1,5$  W)  
Voltage reference diodes  
Tuner diodes

## Part 2 Low frequency transistors

July 1974

## Part 3 High frequency and switching transistors

October 1974

## Part 4a Special semiconductors

November 1974

Transmitting transistors  
Microwave devices  
Field-effect transistors

Dual transistors  
Microminiature devices for  
thick- and thin-film circuits

## Part 4b Devices for opto-electronics

December 1974

Photosensitive diodes and transistors  
Light emitting diodes  
Photocouplers

Infra-red sensitive devices  
Photoconductive devices

## Part 5 Linear integrated circuits

July 1973

## Part 6 Digital integrated circuits

April 1974

DTL (FC family)  
CML (GX family)

MOS (FD family)  
MOS (FE family)

Special Quality tubes



**PREFACE**

Part 3 of our Electron Tubes series will appear much less frequently than most other volumes because interest in Special Quality tubes is now on the decline. Semiconductor products have taken over the functions previously performed by these vacuum tubes: new equipment design is based on semiconductor technology.

Good servicing practice makes the availability of replacement tubes a necessity during the lifetime of existing equipment. For us, as manufacturers of tubes, this means that the demand for Special Quality tubes will gradually decrease. Some types will be available for quite a long time, others will rapidly reach uneconomic levels of production and finally become obsolescent.

By labelling the first page of a set of data "Maintenance type" or "Obsolescent type" we have indicated the status of the tube at the time of going to press. The labelling procedure will, of course, continue after this volume has been printed and more types will become obsolescent before the next edition appears.

We strongly recommend our customers to consult their equipment part lists and to contact our local sales office to ascertain future tube deliveries.

To be independent of future supply uncertainties we advise customers to build up a stock of Special Quality tubes sufficient for their planned equipment lifetime maintenance. They, better than anyone else, know the importance of the equipment: the cost of spare tubes is only a fraction of that value.

Some devices are labelled

Maintenance type

Obsolescent type

or

Obsolete type

Maintenance type - Available for equipment maintenance  
No longer recommended for equipment production.

Obsolescent type - Available until present stocks are exhausted.

Obsolete type - No longer available.







---

---

# GENERAL OPERATIONAL RECOMMENDATIONS SPECIAL QUALITY TUBES



## 1. GENERAL

Deviations from these directives will be stated on the individual data sheets. If applications are considered not referred to in the data of the relevant tube type extra care should be taken with circuit design to avoid that the tube is overloaded due to unfavourable operating conditions.

Also in the circuit design use might be made of tube characteristics not controlled by the manufacturer. When at a later date batches of tubes are delivered which show different values for these characteristics this may result in unsatisfactory performance of the equipment.

## 2. NOMINAL AND SPREAD VALUES OF TUBE CHARACTERISTICS

Tube data not stated as maximum or minimum values apply to a nominal tube. Equipment design should be based on the characteristics as stated in the data sheets.

With measurements carried out with a small number of tubes and in particular with new tube types it should be taken into account that average and spread values may differ from those obtained at larger quantities.

## 3. SPREAD AND VARIATION OF OPERATING CONDITIONS

Parameter values which define the operating conditions may be subject to spread and/or variation.

3.1 Spread. Spread of a parameter value will result in individual values permanently deviating from the average value. The nominal value is the average of such a number of individual values taken at random that an increase of the number will have a negligible influence on the average value.

3.2 Variation. Variation of a parameter value is the change of value occurring as a function of time.

The nominal value is the average value calculated over a period such that a prolongation of that period will have a negligible influence on the average value.

---

---

#### 4. LIMITING VALUES

Limiting values should be used in accordance with the applicable rating system as defined by I.E.C. publication 134.

Reference may be made to one of the following 3 rating systems.

- 4.1 Absolute maximum rating system. Absolute maximum ratings are limiting values of operating and environmental conditions applicable to any electronic device of a specified type as defined by its published data, and should not be exceeded under the worst probable conditions.

These values are chosen by the device manufacturer to provide acceptable serviceability of the device, taking no responsibility for equipment variations, environmental variations, and the effects of changes in operating conditions due to variations in the characteristics of the device under consideration and of all other electronic devices in the equipment.

The equipment manufacturer should design so that, initially and throughout life, no absolute-maximum value for the intended service is exceeded with any device under the worst probable operating conditions with respect to supply voltage variation, equipment components variation, equipment control adjustment, load variations, signal variation, environmental conditions, and variations in characteristics of the device under consideration and of all other electronic devices in the equipment.

- 4.2 Design-maximum rating system. Design-maximum ratings are limiting values of operating and environmental conditions applicable to a bogey electronic device of a specified type as defined by its published data, and should not be exceeded under the worst probable conditions.

These values are chosen by the device manufacturer to provide acceptable serviceability of the device, taking responsibility for the effects of changes in operating conditions due to variations in the characteristics of the electronic device under consideration.

The equipment manufacturer should design so that, initially and throughout life, no design-maximum value for the intended service is exceeded with a bogey device under the worst probable operating conditions with respect to supply-voltage variation, equipment component variation, variation in characteristics of all other devices in the equipment, equipment control adjustment, load variation, signal variation and environmental conditions.

- 4.3 Design-centre rating system. Design-centre ratings are limiting values of operating and environmental conditions applicable to a bogey electronic device of a specified type as defined by its published data, and should not be exceeded under normal conditions.

---

---

These values are chosen by the device manufacturer to provide acceptable serviceability of the device in average applications, taking responsibility for normal changes in operating conditions due to rated supply-voltage variation, equipment component variation, equipment control adjustment, load variation, signal variation, environmental conditions, and variations in the characteristics of all electronic devices.

The equipment manufacturer should design so that, initially, no design-centre value for the intended service is exceeded with a bogey electronic device in equipment operating at the stated normal supply-voltage.

4.4 In addition to the limiting values given in the individual data sheets the directives in the following paragraphs should be observed.

## 5. ELECTRODE VOLTAGE

Two limiting values of electrode voltage are given

a)  $V_{a_0}$ ,  $V_{g_{20}}$  etc.

These values are continuously permitted at zero anode current and with cold cathode. They are also permitted as peak voltage during operation when a D.C. voltage in combination with a superimposed A.C. voltage are present at the electrode provided that the peak value coincides with approx. zero electrode current.

b)  $V_a$ ,  $V_{g_2}$  etc.

These values are D.C. components of the electrode voltages and are continuously permitted.

In circuits with automatic gain control the D.C. component may exceed the published limiting value with 20% provided that the increase of voltage is solely resulting from the gain control and that the maximum voltage coincides with approximately zero electrode current.

## 6. ELECTRODE CURRENT

The limiting values  $I_a$ ,  $I_{g_2}$  etc. are the D.C. components of the electrode currents calculated over 20 ms.

If no specific pulse ratings apply a peak value  $2xI_a$ ,  $I_{g_2}$  etc. is permitted for 10 ms maximum.

## 7. ELECTRODE DISSIPATION

The limiting values  $W_a$ ,  $W_{g_2}$  etc. are the average values at an averaging time of 1 s. If for audio output tubes a limiting value  $W_{g_{2p}}$  is given this value applies to operation with speech and music excitation and should not be exceeded if measured with a sinusoidal signal and at maximum output. If load values vary during operation care should be taken not to exceed the limiting values of  $W_a$  and  $W_{g_2}$ .

---

---

## 8. HEATER VOLTAGE

The average heater voltage should be the specified nominal value. Variation of the heater voltage exceeding the range of  $V_f \text{ nom.} \pm 5\%$  will shorten the tube life.

## 9. SUPPLY VOLTAGE

If design centre ratings apply the variation of supply voltage should not exceed the range of the nominal value  $\pm 10\%$ .

## 10. RESISTANCE VALUES

If design centre ratings apply the spread of resistance values should be limited such that with all other conditions nominal no electrode voltages or currents will exceed the range of their nominal values  $\pm 5\%$ .

## 11. HEATER CATHODE CIRCUIT

Limiting values of  $V_{kf}$  apply to the positive and negative D.C. component of the voltage between the cathode and any of the heater terminals.

The limiting peak value is 2 times the rated D.C. value with a maximum of 315 V.

At the published values only the risk of breakdown is considered. No conclusions with respect to hum should be drawn from this figure.

To minimise the influence of variation and spread of the leakage current between heater and cathode the resistance of the external heater to cathode circuit should not exceed 20 k $\Omega$  in R.F. circuits where frequency stability or preservation of wave form is required and in A.F. circuits with low signal level.

However, when the D.C. value of  $V_{kf}$  is at least 3 times the RMS value of the heater voltage an external resistance between heater and cathode of maximum 220 k $\Omega$  can be used provided that the hum voltage which may then occur across the cathode resistor can be accepted for the application considered.

## 12. SUPPRESSOR GRID CIRCUIT

The voltage of the suppressor grid with respect to the cathode should not be positive and should not exceed 35 V.

The external resistance in the suppressor grid circuit should not exceed 5 k $\Omega$ .

---

---

### 13. CONTROL GRID CIRCUIT

In the interest of low hum and noise the resistance in the control grid circuit should be as low as possible.

The limiting value of the grid resistance given in the data sheets is chosen so that the negative grid current which may occur during life will not result in unacceptable tube operation.

If only the limiting value of the resistance for fixed bias operation is given and stabilizing elements are used in the circuit, this limiting value may be multiplied by the D.C. feedback factor obtained by these stabilizing elements to a maximum of 20 M $\Omega$ .

### 14. SHOCK AND VIBRATION

The conditions specified under "shock and vibration resistance" are test conditions applied to assess the mechanical quality of the tube.

These conditions are not intended to be used as normal operating conditions.

### 15. LIFE

In the interest of a satisfactory life performance and especially where long life is required the tube should be operated under the conditions quoted under "operating conditions". Spread and variation of operating conditions should be limited as much as possible. In this respect the operation with high cathode resistor values and positive grid bias is to be preferred.

Variation of heater voltage should not exceed the limits indicated in item 8 or if applicable, the limiting values specified in the individual tube data sheets.

### 16. HUM

A.F. application. If in the data an equivalent hum voltage on the control grid is given this value applies to the following conditions:

1. The frequency of the heater voltage is 50 c/s + 3% harmonics 500 c/s.
2. The hum voltage is measured as the equivalent RMS value with a filter of 45-550 c/s with a straight response curve.
3. The value of the impedance in the control grid circuit ( $Z_{g1}$ ) does not exceed the value published with respect to hum.
4. The impedance in the cathode circuit is as specified with respect to hum. If no value is given the hum voltage across the cathode resistor is considered to be negligible.
5. The heater terminals and supply leads are screened with respect to the other electrode terminals unto the tube bottom.
6. The A.C. voltage between cathode and heater does not exceed the value corresponding with the method of earthing of the heater circuit specified with respect to hum.

---

---

## 17. MICROPHONY

The performance of an equipment with respect to microphony is defined by the following conditions:

1. The microphony performance of the relevant tube type.
2. The acceleration applied to the tube during operation.
3. The A.F. amplification between the input of the tube and the output of the applied circuit.

In many applications a tube is subject to accelerations applied via the tube socket or, however to a less extent, via the surrounding air.

The acceleration may be produced by a loudspeaker or by the operation of a motor or of a switch.

Measurements to reduce the acceleration should be directed to mechanical or acoustical isolation of the tube.

If mechanical isolation is required the application of a flexible tube holder is advised.

## 18. ENVIRONMENTAL CONDITIONS

- 18.1 Atmospheric pressure. Ratings apply to operation at normal atmospheric pressure at altitudes below 3000 m.

In order to avoid the risk of external flashovers it is advised to consult us if tubes have to be operated at lower pressures.

- 18.2 Bulb and base temperature. The bulb and the base temperature are defined as the highest temperature at any place on the bulb or the base.

The base temperature should not exceed 165 °C.

If the maximum permitted base or bulb temperature is exceeded life performance may deteriorate. Adequate cooling should therefore be observed and may be obtained by convection, radiation or conduction.

A tube mounted in free air may be cooled by convection and by radiation. In order to obtain the most efficient cooling a free circulation of air should be assured around the tube and neighbouring bodies should be maintained at low temperature.

These neighbouring bodies should preferably approach the condition of a perfect black body.

With the design of screening- or retaining devices free circulation of cooling air should be permitted and reflection of heat back on to the bulb must be avoided.

Where the forementioned requirements cannot be met due to mechanical limitation or high altitude or where the temperature of the air available for circulation is too high, forced air cooling or conduction can be adopted. In some cases it may be necessary to reduce the electrode dissipation.

If a good thermal contact can be maintained between the glass surface of the tube and the heat conducting mass on which it is mounted and if this mass is at a sufficiently low temperature, cooling by air circulation may not be necessary. This method is particularly suitable for tubes with flying leads when the mechanical arrangements are not likely to allow free air cooling.



- 
- 
- 18.3 Flashover. To avoid insulation breakdown due to ionization or tracking at high electrode voltages adequate ventilation is required.  
High voltage terminals should not have sharp or pointed edges.

## 19. MOUNTING AND WIRING

- 19.1 Mounting position. A tube may be mounted in any position. The vertical position however, is recommended.

- 19.2 Pins and sockets. Subminiature tubes employ semi-rigid pins.

To ensure that these pins are straight before insertion into the tube socket use may be made of a pin straightening tool. It is recommended both in wired and in printed circuits to use sockets with floating contacts. The connections to these floating contacts should be as flexible as possible.

Where the floating contacts are rigidly attached to the contact tags, a wiring jig should be used to ensure that the socket contacts are in the correct position to receive a tube after the socket has been wired. The use of too stiff wiring will destroy the advantage provided by the float of the contacts and may hold the contact so far out of position as to result in damage of the tube base.

No connections should be made to a pin marked i.c.

- 19.3 Flexible leads. Where tubes with flexible leads are employed without plug in sockets and are held in position by means of the envelope, such support should not cause undue stress on the leads.

- 19.4 Soldering. Where the leads are connected by soldering they should not be sharply bent close to the glass. It should also be avoided that the glass to metal seal is overheated.

The leads therefore should not be soldered nearer than 5 mm to the glass and use may be made of a thermal shunt between the glass and the soldering point.

- 19.5 Magnetic and electrostatic fields. To avoid unwanted effects of magnetic or electrostatic fields a tube should be positioned or shielded as to reduce such effects to a minimum.

- 19.6 Retaining devices. If measures are required to prevent a tube being shaken out of the holder a retaining device may be used.

Care should then be taken not to exceed the maximum permitted bulb temperature.

- 19.7 Floating electrodes. All tube electrodes should have a D.C. connection to the cathode. An interruption of the D.C. connection between cathode and earth or heater and earth may introduce heater-cathode breakdown and should be avoided.



## S.Q. TUBE

Special quality pentode designed for use as A.F. and R.F. amplifier, output tube, oscillator a.o.

## QUICK REFERENCE DATA

Life test	10 000 hours
Base	Loctal
Heating	Indirect A.C. or D.C. Series or parallel supply
Heater voltage	$V_f$ 20 V
Heater current	$I_f$ 125 mA
Anode current	$I_a$ 16 mA
Mutual conductance	S 6.5 mA/V
Equivalent noise resistance	$R_{eq}$ 1200 $\Omega$
Hum voltage	$V_{geq}$ 10 $\mu V_{RMS}$

## DIMENSIONS AND CONNECTIONS

Dimensions in mm

Base: Loctal

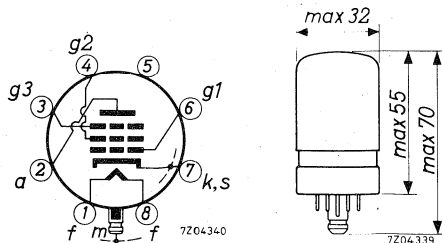

## CHARACTERISTICS

Column I Nominal value or setting of the tube

II Range values for equipment design: Initial spread

III Range values for equipment design: End of life

		I	II	III	
Heater voltage	$V_f$	20			V
Heater current	$I_f$	125	120 - 130		mA
Anode supply voltage	$V_{ba}$	225			V
Grid No. 2 supply voltage	$V_{bg_2}$	155			V
Grid No. 3 voltage	$V_{g_3}$	0			V
Cathode resistor	$R_k$	250			$\Omega$
Anode current	$I_a$	16	13.5 - 19	min. 11.5	mA
Grid No. 2 current	$I_{g_2}$	3	2 - 4		mA
Mutual conductance	S	6.5	5.5 - 7.8	min. 4.5	mA/V
Internal resistance	$R_i$	250	min. 200		$k\Omega$
Amplification factor	$\mu_{g_2g_1}$	19			
<u>Negative grid current</u>	$-I_g$		max. 0.5	max. 1.0	$\mu A$
<u>Output power</u>	$W_o$	1.5			W
Anode load resistance $R_{a\sim} = 10 k\Omega$					
Total distortion $d_{tot} = 10 \%$					
<u>Cathode heating time</u>		26	19 - 33		sec
Anode current $I_a = 4$ mA					
<u>Equivalent noise resistance</u>					
R. F.	$R_{eq}$	1200	max. 2000		$\Omega$
R. F. connected as triode	$R_{eq}$	650			$\Omega$
A. F. (500 - 3000 Hz)	$R_{eq}$	5000			$\Omega$

**CHARACTERISTICS** (continued)

		II	III	
<u>Insulation between cathode and heater</u>	$I_{kf}$	max. 0.5	max. 1.0	$\mu A$
Voltage between cathode and heater $V_{kf} = 50$ V (cathode positive)				
<u>Insulation between two electrodes</u>	$R_{ins}$	min. 1000	min. 300	$M\Omega$
Voltage between electrodes $V = 50$ V				
<u>Hum voltage</u>	$V_{geq}$	max. 10		$\mu V_{RMS}$
Grid No. 1 resistor $R_{g1} = 500$ k $\Omega$				
Cathode by-pass capacitor $C_k = 100$ $\mu F$				
Heater centre earthed				

**CAPACITANCES**

		I	II	
Grid No. 1 to grid No. 2, grid No. 3, cathode, heater and screen	$C_{g1/g2g3kfs}$	8.5	7.5 - 9.5	pF
Grid No. 1 to grid No. 2, grid No. 3, cathode, heater and screen	$C_{g1/g2g3kfs}$	10.5		pF
Cathode current $I_k = 19$ mA				
Anode to grid No. 2, grid No. 3, cathode, heater and screen	$C_{a/g2g3kfs}$	6.0	4.5 - 7.7	pF
Grid No. 1 and anode to grid No. 3, grid No. 2, cathode, heater and screen	$C_{g1a/g3g2kfs}$		max. 16	pF
Anode to grid No. 1	$C_{ag1}$	14	max. 18	mpF
Grid No. 1 to grid No. 2	$C_{g1g2}$	3		pF
Grid No. 2 to grid No. 3	$C_{g2g3}$	2.2		pF
Grid No. 1 to cathode and screen	$C_{g1/ks}$	4.5		pF
Anode to grid No. 3	$C_{ag3}$	1.2		pF
Grid No. 1 to heater	$C_{g1f}$	20	max. 40	mpF
Anode to heater	$C_{af}$	120		mpF
Cathode and screen to heater	$C_{ks/f}$	7		pF

**CAPACITANCES** (continued)

As triode (Grid No. 2 and grid No. 3 connected to anode)

	I	II	
Grid No. 1 to cathode, heater and screen	5	max. 6	pF
Anode, grid No. 2 and grid No. 3 to cathode, heater and screen	7.5	max. 9	pF
Anode, grid No. 2 and grid No. 3 to grid No. 1	3.2	max. 4	pF

**LIFE**

Production samples are tested to be within the end of life values (column III) under the following conditions during 10 000 hours.

Heater voltage	$V_f$	20	V
Anode supply voltage	$V_{ba}$	225	V
Grid No. 2 supply voltage	$V_{bg_2}$	155	V
Grid No. 3 voltage	$V_{g_3}$	0	V
Cathode resistor	$R_k$	250	$\Omega$

**LIMITING VALUES** Design centre rating system.

Anode voltage	$V_{a_0}$	max.	550	V
	$V_a$	max.	300	V
Anode dissipation	$W_a$	max.	4	W
	$V_{g_3}$	max.	550	V
Grid No. 3 voltage	$V_{g_3}$	max.	300	V
	$W_{g_3}$	max.	1	W
Grid No. 3 dissipation	$V_{g_2}$	max.	550	V
	$V_{g_2}$	max.	300	V
Grid No. 2 voltage	$W_{g_2}$	max.	1	W
	$W_{a+g_2+g_3}$	max.	5	W
Dissipation of anode, grid No. 2 and grid No. 3 (triode connected)	$-V_{g_1}$	max.	100	V
Grid No. 1 voltage	$W_{g_1}$	max.	50	mW
Grid No. 1 dissipation	$I_k$	max.	30	mA
Cathode current				

**LIMITING VALUES** (continued)

Grid No. 1 resistor	$R_{g1}$	max.	0.5 $M\Omega$
Anode dissipation > 1.5 W			
Grid No. 1 resistor	$R_{g1}$	max.	3 $M\Omega$
Anode dissipation < 1.5 W			
Voltage between cathode and heater	$V_{kf}$	max.	120 V
Bulb temperature (Metal envelope)	$t_{bulb}$	max.	120 $^{\circ}C$

Heater voltage: The average heater voltage should be 20 V.

Variations of the heater voltage exceeding the range of 19 V to 21 V will shorten the tube life.

The tolerance of heater current (column II) should be taken into account.



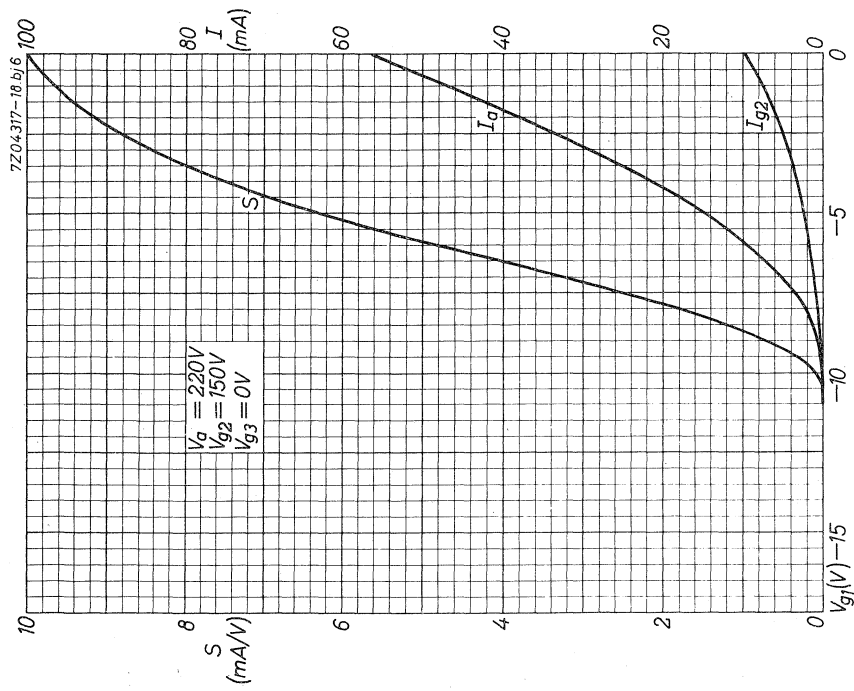
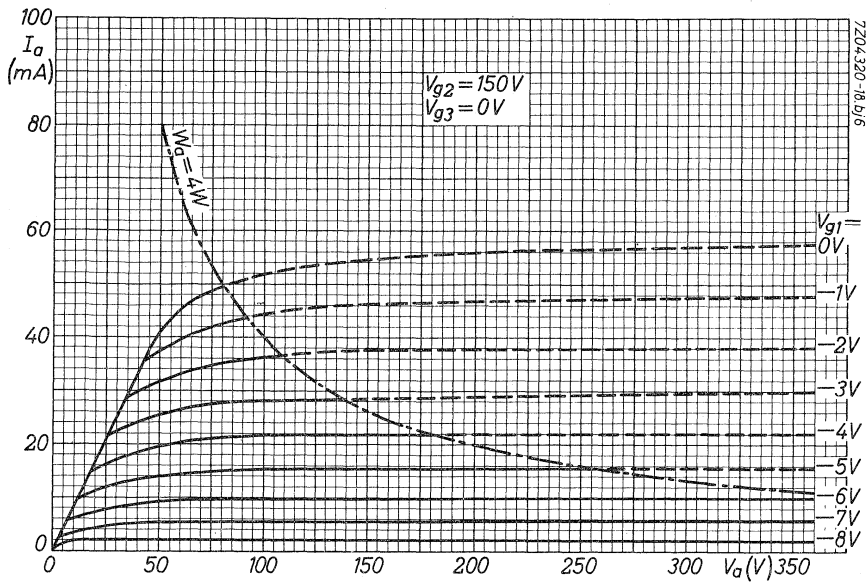

## S.Q. TUBE

Special quality pentode designed for use as wide band amplifier

### QUICK REFERENCE DATA

Life test	10 000 hours	
Low interface resistance		
Base	Noval. Gold plated pins	
Heating	Indirect A.C. or D.C.; Parallel supply	
Heater voltage	$V_f$	6.3 V
Heater current	$I_f$	315 mA
Anode current	$I_a$	22 mA
Mutual conductance	S	35 mA/V
Equivalent noise resistance	$R_{eq}$	150 $\Omega$

### DIMENSIONS AND CONNECTIONS

Dimensions in mm

Base: Noval

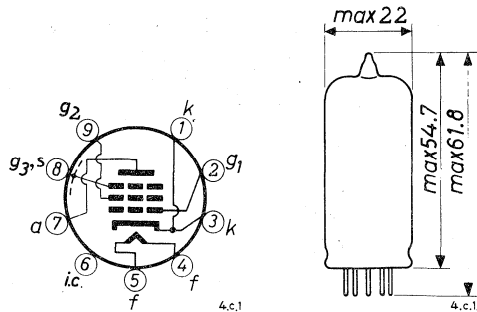

**CHARACTERISTICS**

Column I Nominal value or setting of the tube

II Range values for equipment design: Initial spread

III Range values for equipment design: End of life

		I	II	III	
Heater voltage	$V_f$	6.3			V
Heater current	$I_f$	315	299	331	mA
Anode supply voltage	$V_{ba}$	190			V
Grid No.2 supply voltage	$V_{bg_2}$	160			V
Grid No.3 voltage	$V_{g_3}$	0			V
Grid No.1 supply voltage	$+V_{bg_1}$	10			V
Cathode resistor	$R_k$	400			$\Omega$
Anode current	$I_a$	22	21 - 23	min. 20	mA
Grid No.2 current	$I_{g_2}$	6.0	5.4 - 6.6		mA
Internal resistance	$R_i$	120			k $\Omega$
Mutual conductance	$S$	35	30 - 40	min. 24.5	mA/V
Amplification factor	$\mu_{g_2g_1}$	80			
<u>Negative grid current</u>	$-I_{g_1}$		max. 0.3	max. 1.0	$\mu A$
<u>Equivalent noise resistance</u>	$R_{eq}$	150			$\Omega$
<u>Input resistance</u>	$R_{g_1}$	1			k $\Omega$
Frequency = 100 MHz pin No.1 connected to pin No.3					
$\frac{S}{2\pi} \cdot \frac{1}{C_{g_1}(\text{hot}) + C_a + 5 \text{ pF}}$		230			MHz
<u>Noise factor</u>	$F$	7			dB
Frequency = 100 MHz (Adapted to minimum noise)					
<u>Phase angle of slope</u>	$\varphi_s$	22			$^\circ$
Frequency = 100 MHz					

**CHARACTERISTICS** (continued)

<u>As triode</u> (grid No.2 connected to anode)		I	II	
Anode supply voltage	$V_{ba}$	160		V
Grid No.3 voltage	$V_{g3}$	0		V
Grid No.1 supply voltage	$+V_{bg1}$	10		V
Cathode resistor	$R_k$	470		$\Omega$
Anode current	$I_a$	24		mA
Mutual conductance	$S$	41		mA/V
Amplification factor	$\mu$	77		
Internal resistance	$R_i$	1.9		k $\Omega$
<u>Equivalent noise resistance</u>	$R_{eq}$	65		$\Omega$
<u>Insulation resistance between anode and other electrodes</u> Voltage between electrodes = 300 V	$R_{ins}$		min. 500	M $\Omega$
<u>Insulation resistance between grid No.1 and other electrodes</u> Voltage between electrodes = 50 V	$R_{ins}$		min. 200	M $\Omega$
<u>Leakage current between cathode and heater</u> Voltage between cathode and heater = 100 V	$I_{kf}$		max. 5	$\mu$ A
<b>CAPACITANCES</b>				
<u>Without external shield.</u>				
Grid No.1 to grid No.2, grid No.3, cathode, heater and screen	$C_{g1/g2g3kfs}$	10	9- 11	pF
Grid No.1 to grid No.2, grid No.3, cathode, heater and screen Cathode current = 28 mA	$C_{g1/g2g3kfs}$	17		pF
Anode to grid No.2, grid No.3, cathode, heater and screen	$C_{a/g2g3kfs}$	2.1	1.8- 2.4	pF

**CAPACITANCES** (continued)

		I	II	
Anode to grid No.1	$C_{ag_1}$		max. 40	mpF
Anode to cathode	$C_{ak}$		max. 50	mpF
Anode to cathode and grid No.2	$C_{a/kg_2}$	0.32	0.28-0.36	pF
Anode to cathode, grid No.2 and grid No.3	$C_{a/kg_2g_3}$	2.0	1.7- 2.3	pF
Anode to heater	$C_{af}$		max. 100	mpF
Grid No.1 to cathode	$C_{g_1k}$	6.8	6.1- 7.5	pF
Grid No.1 to cathode and grid No.2	$C_{g_1/kg_2}$	9.5	8.5-10.5	pF
Grid No.1 to cathode, grid No.2 and grid No.3	$C_{g_1/kg_2g_3}$	10	9- 11	pF
<u>With external shield</u>				
Grid No.1 to grid No.2, grid No.3, cathode, heater and screen	$C_{g_1/g_2g_3kfs}$	10.1	9.1-11.1	pF
Grid No.1 to grid No.2, grid No.3, cathode, heater and screen Cathode current = 28 mA	$C_{g_1/g_2g_3kfs}$	17.1		pF
Anode to grid No.2, grid No.3, cathode, heater and screen	$C_{a/g_2g_3kfs}$	3.3	2.9- 3.7	pF
Anode to grid No.1	$C_{ag_1}$		max. 35	mpF
<u>As triode. Without external shield.</u>				
Grid No.3 connected to cathode				
Grid No.1 to grid No.3, cathode, heater and screen	$C_{g_1/g_3kfs}$	7.3		pF
Anode and grid No.2 to grid No.3, cathode, heater and screen	$C_{ag_2/g_3kfs}$	3.1		pF
Anode and grid No.2 to grid No.1	$C_{ag_2/g_1}$	2.7		pF
<u>As triode. Without external shield</u>				
Grid No.3 connected to anode				
Grid No.1 to cathode, heater and screen	$C_{g_1/kfs}$	6.7		pF
Anode, grid No.2 and grid No.3 to cathode, heater and screen	$C_{ag_2g_3/kfs}$	1.0		pF
Anode, grid No.2 and grid No.3 to grid No.1	$C_{ag_2g_3/g_1}$	3.3		pF

**LIFE**

Production samples are tested to be within the end of life values (column III) during 10 000 hours.

**LIMITING VALUES** (Design centre rating system, if not otherwise specified)

Anode voltage		$V_{a0}$	max.	400 V
		$V_a$	max.	220 V
Anode dissipation	Des. centre	$W_a$	max.	4.2 W
	Abs. max.	$W_a$	max.	4.5 W
Grid No.2 voltage		$V_{g20}$	max.	400 V
		$V_{g2}$	max.	180 V
Grid No.2 dissipation	Des. centre	$W_{g2}$	max.	1.0 W <sup>1)</sup>
	Abs. max.	$W_{g2}$	max.	1.1 W <sup>1)</sup>
Anode plus grid No.2 dissipation (triode connected)		$W_{a+g2}$	max.	4.5 W
Grid No.1 voltage		$-V_{g1}$	max.	30 V
		$+V_{g1}$	max.	0 V
Cathode current	Des. centre	$I_k$	max.	30 mA
	Abs. max.	$I_k$	max.	33 mA
Grid resistor (Automatic bias)		$R_{g1}$	max.	0.5 M $\Omega$
Voltage between cathode and heater				
cathode positive		$V_{kf}$	max.	120 V
cathode negative		$V_{kf}$	max.	60 V
Bulb temperature	Abs. max.	$t_{bulb}$	max.	190 °C

Heater voltage: The average heater voltage should be 6.3 V.

Variations of the heater voltage exceeding the range of 6.0 V to 6.6 V will shorten the tube life.

The tolerance of heater current (column II) should be taken into account.

<sup>1)</sup> Care should be taken not to exceed the rated  $W_{g2}$  values due to switching of positive supply voltages.

If the cathode is shunted by a capacitance > 10  $\mu$ F a series resistor of minimum 1 k $\Omega$  should be inserted in the grid No.1 lead.

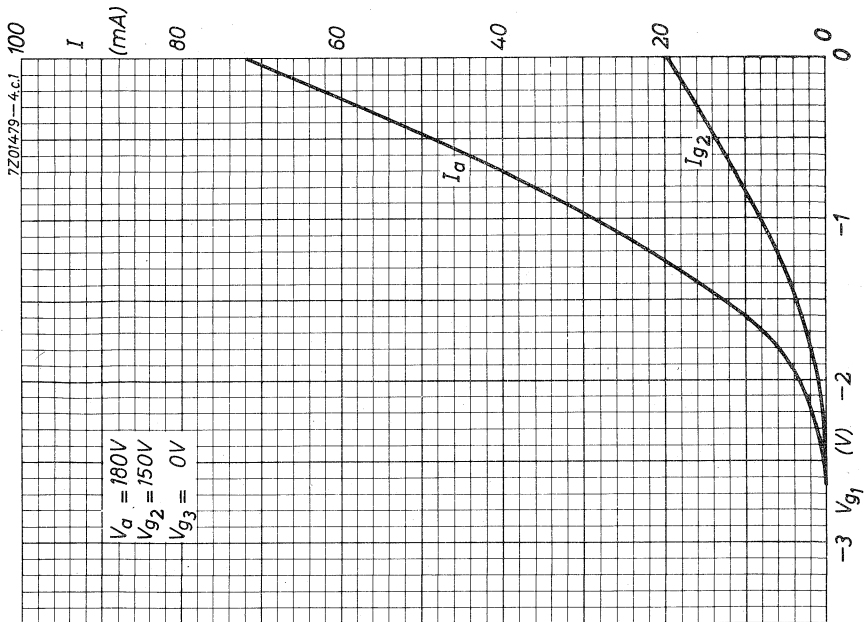
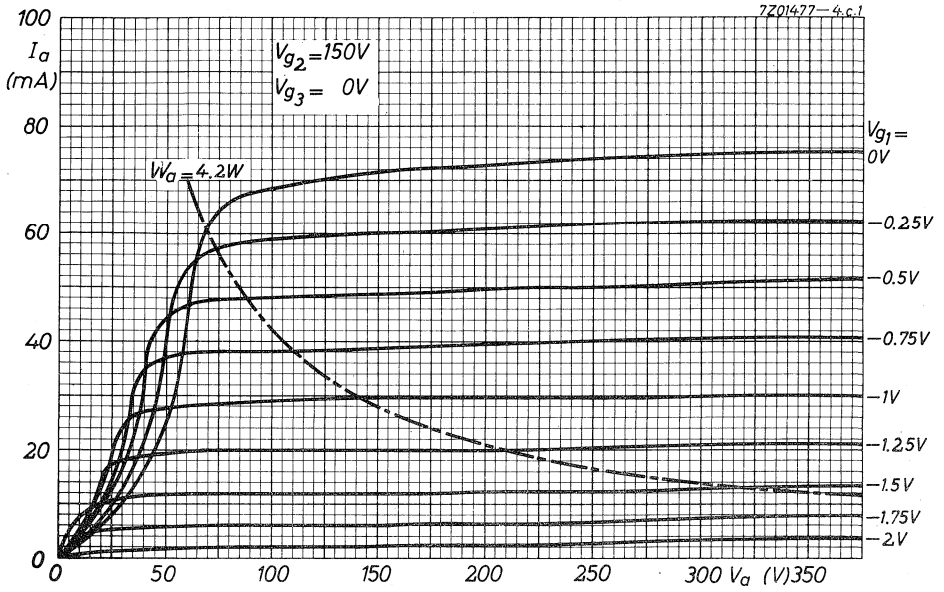



## S.Q. INDICATOR TUBE

High-input impedance, special-quality indicator tube for indication of the output level of flip flops in computer circuits etc.

QUICK REFERENCE DATA		
Life test	10 000 hours	
Mechanical quality	Shock and vibration resistant	
Base	Subminiature	
Heating	Direct	
	A. C. or D. C.; parallel supply	
Filament voltage	$V_f$	1.0 V
Filament current	$I_f$	30 mA
"On"-"off" control voltage	$\Delta V$	min. 1.4 V

### DIMENSIONS AND CONNECTIONS

Dimensions in mm ←

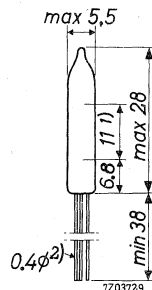
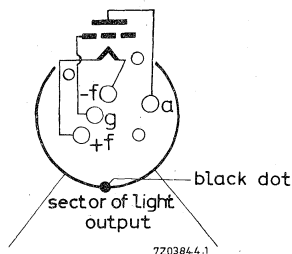

Connections should not be soldered nearer than 5 mm from the seal.  
 Leads should not be bent nearer than 1.5 mm from the seal.  
 The axis of the light output indicated by a black dot.

1) Length of the light bar.

2) Leads without letter indication are cut at the outer surface of the seal.

**CHARACTERISTICS**

- Column I Nominal value or setting of the tube
- II Range values for equipment design: Initial spread
- III Range values for equipment design: End of life

	I	II	III	
Filament voltage	$V_f$ 1.0			V
Filament current	$I_f$ 30	24-36		mA
Anode voltage	$V_a$ 50			V
Grid resistor	$R_g$ 100			k $\Omega$
Grid supply voltage <sup>1)</sup> (maximum light output)	$V_{bg}$ 0			V
Anode current	$I_a$ 585	430-740	min. 250	$\mu$ A
Zero light output is ensured when grid supply voltage <sup>1) 2)</sup> is below	$V_{bg}$ -3	-3	-3	V
Anode current at $V_{bg} = -3$ V <sup>2)</sup>	$I_a$	max. 5	max. 5	$\mu$ A
Insulation resistance between two electrodes Voltage between two electrodes = 50 V	$R_{ins}$	min.100		M $\Omega$

**SHOCK RESISTANCE**

The tube has been subjected 5 times in each of 4 positions to an acceleration of 500 g in an NRL shock machine with the hammer lifted over an angle of 30°. These test conditions should not be considered as normal operating conditions.

**LIFE**

Production samples are checked for the end of life values (column III) under the following conditions during 10 000 hours:

Filament voltage	$V_f$	1.0	V <sub>RMS</sub>
Anode voltage	$V_a$	50	V
Grid supply voltage	$V_{bg}$	0	V <sup>1)</sup>
Grid resistor	$R_g$	100	k $\Omega$

1) Voltage with respect to the midtap of the filament transformer.

2) The residual electron current may be concentrated on one spot which then may be visible in dark surroundings. This effect cannot be mistaken for the indicator being in the "on" condition.

**LIMITING VALUES** (Absolute max. rating system)

Anode voltage	$V_{a0}$	max.	100 V
	$V_a$	max.	65 V
Anode current	$I_a$	max.	850 $\mu$ A
Grid supply voltage, $R_g = 100\text{ k}\Omega \pm 10\%$	$V_{bg}$	max.	0 V
	$V_{bg}$	max.	6 V
Grid voltage	$-V_g$	max.	50 V
		max.	1.1 M $\Omega$
Grid resistor	$R_g$	min.	0.09 M $\Omega$

Filament voltage: The average filament voltage should be 1.0 V.

Variations exceeding 0 or - 10 % from nominal will shorten tube life.

**APPLICATION NOTE**

The visibility of the phosphorescent light produced by the anode when the indicator tube is "on" depends on the grid voltage prevailing in that condition and the illumination level of the surroundings. With  $V_g = -3$  V for zero light output ("off" condition of the tube), the visibility is best when  $\Delta V = 3$  V ( $\Delta V$  is the difference between the "high" and "low" voltages of the flip-flop) but an unambiguous indication is still obtained at  $\Delta V = 1.4$  V under nominal conditions and a low level of ambient light. With still smaller values of drive voltage a pre-amplifier is required.

Figs.1 and 2 show typical arrangements for negative and positive logic, respectively.

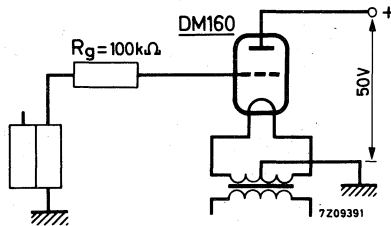

Fig.1 Digital read-out circuit with DM160 connected to negative logic circuit which uses flip-flops equipped with p-n-p transistors. This circuit can be used for all types of flip-flops with p-n-p transistors with the "high" level near zero volt and a "low" level below -3 volt.

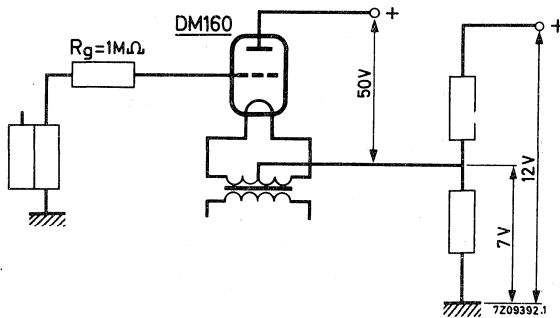

Fig.2 Digital read-out circuit with DM160 connected to positive logic circuit which uses a type of flip-flops equipped with n-p-n transistors and of which the "high" output level may be above +7.5 V and the "low" level near 0 V.  $R_g$  protects the tube against too large anode currents and too large positive grid currents when the grid supply voltage exceeds the cathode potential.

When the minimum of  $\Delta V$  lies below 3 V the spread in the "high" level of the flip-flop will give rise to an extra spread in the brightness of the phosphorescent light. When undesirable this spread may be reduced by clamping the grid voltage, see Fig.3.

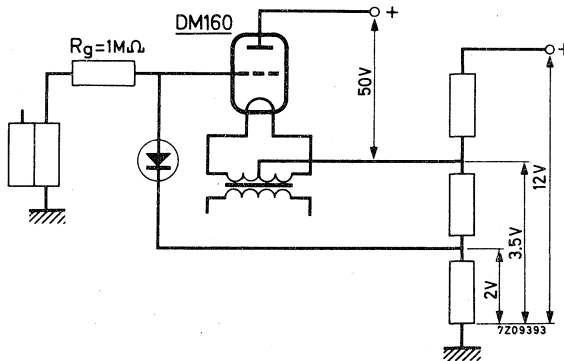
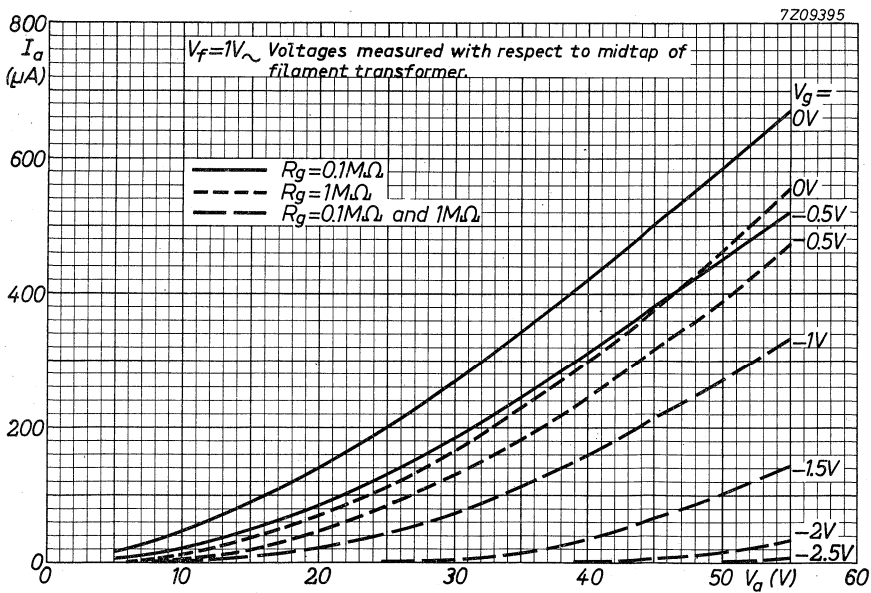
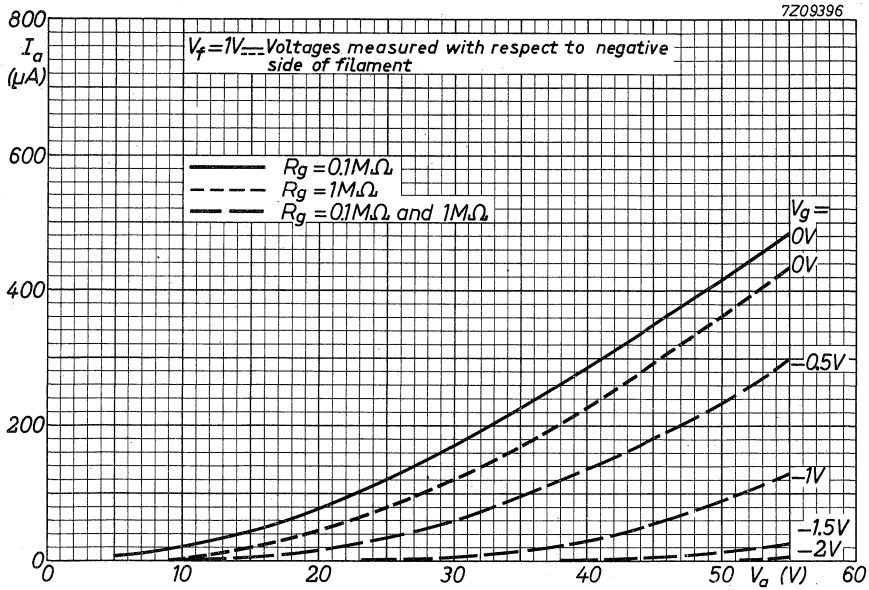
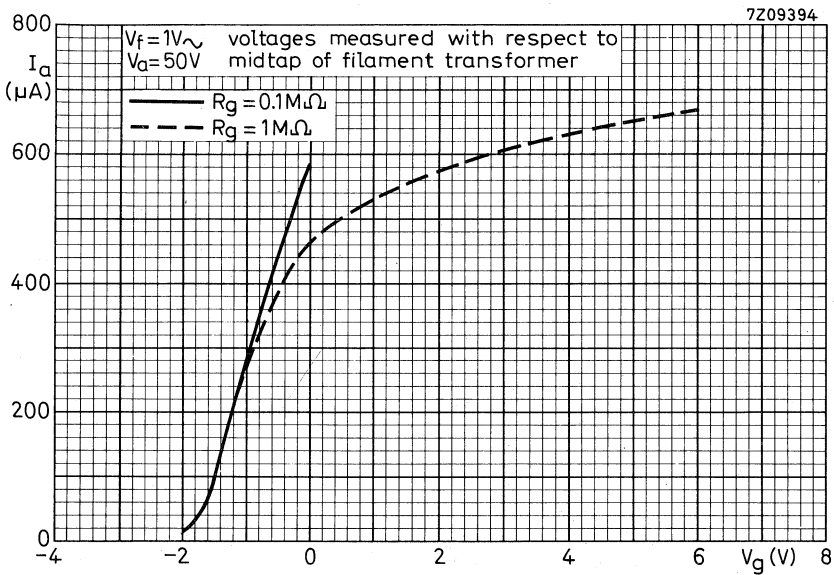

Fig.3 As Fig.2; but for a type of flip-flop with a "high" voltage level between +2.0 V and +7.0 V and "low" level between 0 V and +0.5 V; with clamping of the grid voltage.





## S.Q. TUBE

Special quality pentode designed for use as wide band output tube.

### QUICK REFERENCE DATA

Life test	10 000 hours	
Low interface resistance		
Mechanical quality	Shock and vibration resistant	
Base	Magnoval. Gold plated pins	
Heating	Indirect A.C. or D.C.; Parallel supply	
Heater voltage	$V_f$	6.3 $V \pm 5\%$
Heater current	$I_f$	600 mA
Anode current	$I_a$	50 mA
Mutual conductance	$S$	45 mA/V

### DIMENSIONS AND CONNECTIONS

Dimensions in mm

Base: Magnoval

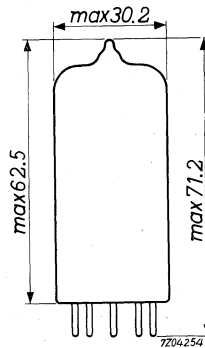
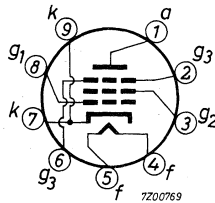

## CHARACTERISTICS

Column I Nominal value or setting of the tube

II Range values for equipment design: Initial spread

III Range values for equipment design: End of life

		I	II	III	
Heater voltage	$V_f$	6.3			V
Heater current	$I_f$	600			mA
Anode voltage	$V_a$	125			V
Grid No.3 voltage	$V_{g3}$	0			V
Grid No.2 voltage	$V_{g2}$	125			V
Grid No.1 voltage	$-V_{g1}$	3			V
Anode current	$I_a$	50			mA
Grid No.2 current	$I_{g2}$	5.5			mA
Mutual conductance	S	45			mA/V
Internal resistance	$R_i$	20			$k\Omega$
Amplification factor	$\mu_{g2g1}$	30			
Input resistance	$R_{g1}$	1			$k\Omega$
Frequency = 50 MHz					
Anode supply voltage	$V_{ba}$	140			V
Grid No.3 voltage	$V_{g3}$	0			V
Grid No.2 supply voltage	$V_{bg2}$	140			V
Grid No.1 supply voltage	$+V_{bg1}$	12			V
Cathode resistor	$R_k$	270			$\Omega$
Anode current	$I_a$	50	48 - 52		mA
Grid No.2 current	$I_{g2}$	5.5	4.5 - 6.5		mA
Grid No.1 to cathode voltage	$-V_{g1k}$	3.0	2.3 - 3.7	1.8	V
Mutual conductance	S	45	38 - 52	$\Delta S =$ max. 25%	mA/V
Negative grid current	$-I_g$			2	$\mu A$



**CHARACTERISTICS** (continued)

As triode (grid No.2 connected to anode)

Anode voltage	$V_a$	125	V
Grid No.1 voltage	$-V_{g1}$	3	V
Anode current	$I_a$	55.5	mA
Mutual conductance	S	50	mA/V
Internal resistance	$R_i$	600	$\Omega$
Amplification factor	$\mu$	30	

**CAPACITANCES**

Pentode connected

		I		II		
		With shield	Without shield	With shield	Without shield	
Anode to grid No.3, grid No.2, cathode and heater	$C_{a/g_3g_2kf}$	6.5	5.8- 7.2	4.0	3.6- 4.4	pF
Grid No.1 to grid No.3, grid No.2, cathode and heater	$C_{g_1/g_3g_2kf}$	18	15- 21	18	15- 20	pF
Grid No.1 to grid No.3, grid No.2, cathode and heater	$C_{g_1/g_3g_2kf}$	28		28		pF
Cathode current $I_k = 55.5$ mA						
Anode to grid No.1	$C_{ag_1}$	80	max. 120	110	max. 150	mpF

Triode connected (grid No.2 connected to anode)

Anode to grid No.3, cathode and heater	$C_{a/g_3kf}$	10.5	9.4-11.6	7.8	7.0- 8.6	pF
Grid No.1 to grid No.3, cathode and heater	$C_{g_1/g_3kf}$	11.8	10-13.6	11.8	10-13.6	pF
Anode to grid No.1	$C_{ag_1}$	6.2	5.5- 6.9	6.3	5.6- 7.0	pF
Cathode to heater	$C_{kf}$	6.0		6.0		pF

**SHOCK AND VIBRATION RESISTANCE**

The following test conditions are applied to assess the mechanical quality of the tube. These conditions are not intended to be used as normal operating conditions.

Shock

The tube is subjected 5 times in each of 4 positions to an acceleration of 500 g supplied by an NRL shock machine with the hammer lifted over an angle of 30°.

Vibration

The tube is subjected during 32 hours in each of 3 positions to a vibration frequency of 50 Hz with an acceleration of 2.5 g.

**LIMITING VALUES** (Absolute max. rating system)

Anode voltage	$V_{a_0}$	max.	400 V
	$V_a$	max.	200 V
Anode dissipation	$W_a$	max.	10 W
Grid No.2 voltage	$V_{g_{20}}$	max.	350 V
	$V_{g_2}$	max.	175 V
Grid No.2 dissipation	$W_{g_2}$	max.	1.5 W
Grid No.1 voltage, negative	$-V_{g_1}$	max.	55 V
	positive	$V_{g_1}$	max.
Cathode current	$I_k$	max.	75 mA
Grid No.1 resistor	$R_{g_1}$	max.	125 k $\Omega$
Voltage between cathode and heater	$V_{kf}$	max.	200 V
Bulb temperature	$t_{bulb}$	max.	180 °C

In applications where a long life is not required,  $I_k$  max. can be increased to 100 mA and  $t_{bulb}$  max. to 220 °C

**OPERATING CONDITIONS**

Anode supply voltage	$V_{ba}$	140 V
Grid No.2 supply voltage	$V_{bg2}$	140 V
Grid No.3 voltage	$V_{g3}$	0 V
Grid No.1 supply voltage	$+V_{bg1}$	12 V
Cathode resistor	$R_k$	270 $\Omega$
Anode current	$I_a$	50 mA
Grid No.2 current	$I_{g2}$	5.5 mA
Mutual conductance	$S$	45 mA/V

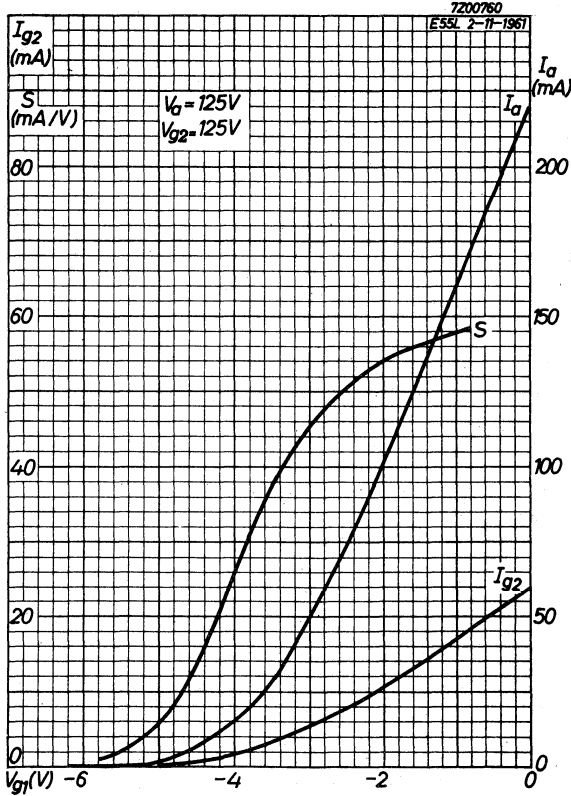

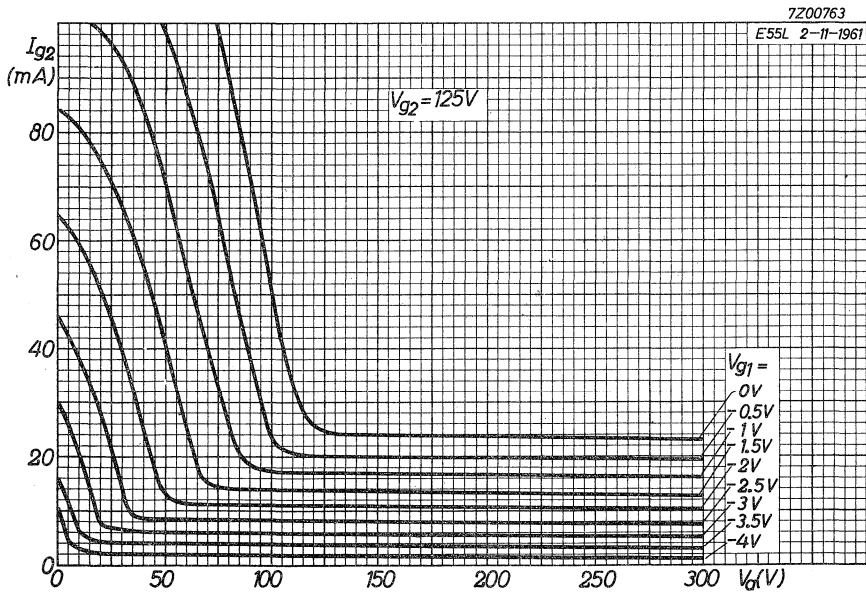
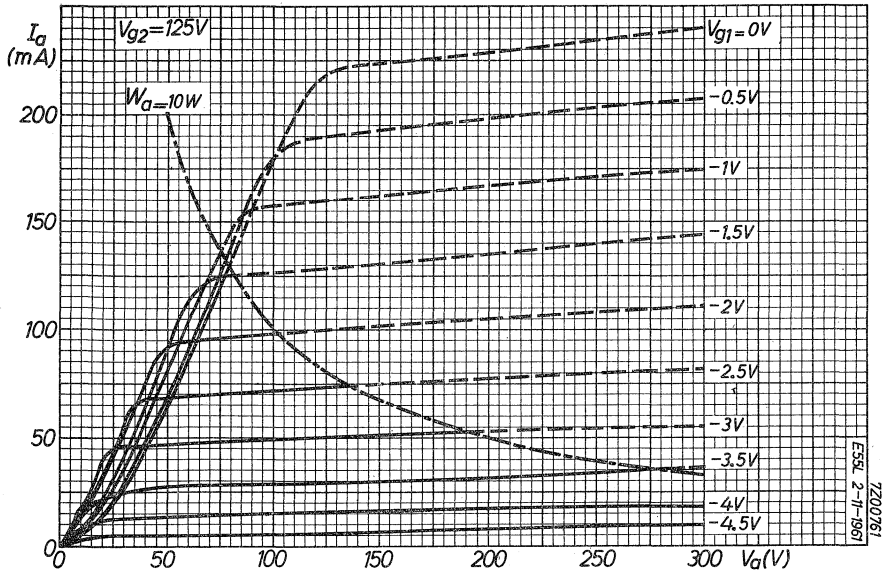

## S.Q. TUBE

Special quality double triode designed for use as A.F. and D.C. amplifier.

QUICK REFERENCE DATA	
Life test	10 000 hours Low interface resistance after long periods of operation under cut-off conditions
Mechanical quality	Shock and vibration resistant
Base	Noval. Gold plated pins
Heating	Indirect A.C. or D.C. Series or parallel supply
Heater voltage	$V_f$ 12.6 6.3 V
Heater current	$I_f$ 0.3 0.6 A
Anode voltage	$V_a$ 250 V
Grid voltage	$V_g$ -5.5 V
Mutual conductance	$S$ 2.7 mA/V

### DIMENSIONS AND CONNECTIONS

Dimensions in mm

Base: Noval

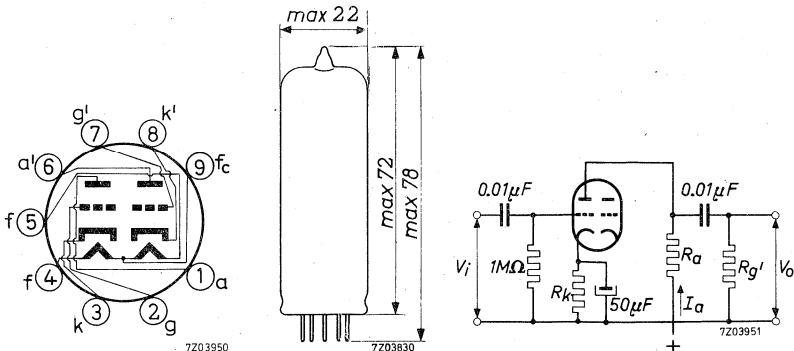

Fig. 1

## CHARACTERISTICS

Column I Nominal value or setting of the tube

II Range values for equipment design: Initial spread

III Range values for equipment design: End of life

		I	II	III	
Heater voltage	$V_f$	12.6			V
Heater current	$I_f$	300	285 - 315		mA
Anode voltage	$V_a$	250			V
Cathode resistor	$R_k$	920			$\Omega$
Anode current	$I_a$	6.0	5.4 - 6.6	min. 4.3	mA
Transconductance	S	2.7	2.2 - 3.2	min. 1.8	mA/V
Amplification factor	$\mu$	27			
Internal resistance	$R_i$	10	min. 7		k $\Omega$
Negative grid current	$-I_g$		max. 0.5	max. 1.0	$\mu$ A
<u>Difference in anode current of two sections</u>	$ I_a - I_a' $		max. 3.0		mA
Anode voltage	$V_a$	250			V
Negative grid voltage	$-V_g$	5.5			V
<u>Cut-off voltage</u>	$-V_g$	17			V
Anode voltage	$V_a$	250			V
Anode resistor	$R_a$	1			M $\Omega$
Anode current	$I_a$		max. 15		$\mu$ A
<u>Hum voltage</u>	$V_g$		max. 75		$\mu$ V <sub>RMS</sub>
Grid resistor $R_g = 0.5$ M $\Omega$					
<u>Leakage current between cathode and heater</u>	$I_{kf}$		max. 12		$\mu$ A
Voltage between cathode and heater $V_{kf} = 120$ V					
Cathode heating time		16	max. 23		sec
Cathode cooling time			min. 13		sec

## CAPACITANCES

		External screen		Without external screen		
		I	II	I	II	
Anode to cathode and heater	$C_{a/kf}$	3.5	2.8 - 4.2	0.45		pF
Grid to cathode and heater	$C_{g/kf}$	2.6	1.9 - 3.3	2.4		pF
Anode to grid	$C_{ag}$	3.0	2.4 - 3.6	3.1		pF
Grid to heater	$C_{gf}$		max. 0.23		max. 0.23	pF
Cathode to heater	$C_{kf}$	4.8		4.8		pF
Anode to cathode and heater	$C_{a'/k'f}$	3.0	2.3 - 3.7	0.55		pF
Grid to cathode and heater	$C_{g'/k'f}$	2.6	1.9 - 3.3	2.4		pF
Anode to grid	$C_{a'g'}$	3.0	2.4 - 3.6	3.0		pF
Grid to heater	$C_{g'f}$		max. 0.23		max. 0.23	pF
Cathode to heater	$C_{k'f}$	4.8		4.8		pF
Anode to anode other section	$C_{aa'}$	1.3	0.9 - 1.7	1.45		pF
Grid to grid other section	$C_{gg'}$		max. 13		max. 13	mpF
Anode to grid other section	$C_{ag'}$		max. 0.1		max. 0.1	pF
Grid to anode other section	$C_{ga'}$		max. 65		max. 65	mpF

## SHOCK AND VIBRATION RESISTANCE

The following test conditions are applied to assess the mechanical quality of the tube. These conditions are not intended to be used as normal operating conditions.

Shock

The tube is subjected 5 times in each of 4 positions to an acceleration of 500 g supplied by an NRL shock machine with the hammer lifted over an angle of 30°.

Vibration

The tube is subjected during 32 hours in each of 3 positions to a vibration frequency of 50 Hz with an acceleration of 2.5 g.

## LIFE

Production samples are tested to be within the end of life values (column III) under the following conditions during 10 000 hours.

Heater voltage	$V_f$	6.3 V
Anode voltage	$V_a$	250 V
Cathode resistor	$R_k$	920 $\Omega$

## LIMITING VALUES (Absolute max. rating system)

Anode voltage	$V_{a0}$	max.	600 V
	$V_a$	max.	300 V
Anode dissipation	$W_a$	max.	2 W
Cathode current	$I_k$	max.	12 mA
Cathode current peak value	$I_{kp}$	max.	150 mA
Grid current peak value max.			30 mA
Duty factor max.			0.005
Pulse duration max.			10 $\mu$ s
Cathode current peak value	$I_{kp}$	max.	30 mA
Grid current peak value max.			2 mA
Duty factor max.			0.2
Pulse duration max.			400 $\mu$ s
Grid voltage	$-V_g$	max.	200 V
Grid current, average value	$I_g$	max.	0.3 mA
peak value	$I_{gp}$	max.	30 mA
Voltage between cathode and heater	$V_{kf}$	max.	120 V
Bulb temperature	$t_{bulb}$	max.	170 $^{\circ}$ C
Grid resistor (automatic bias)	$R_g$	max.	1 M $\Omega$
Grid resistor (fixed bias)	$R_g$	max.	0.5 M $\Omega$

Heater voltage. The average heater voltage should be 6.3 V or 12.6 V. Variations of the heater voltage exceeding the range of 6.0 V to 6.6 V or 12.0 to 13.2 V will shorten the tube life. The tolerance of heater current (column II) should be taken into account.



## OPERATING CHARACTERISTICS

Resistance coupled A.F. amplifier. Fig.1 page 1

Anode supply voltage	$V_{ba}$	200	250	300	350	400	V
Anode resistor	$R_a$	47	47	47	47	47	k $\Omega$
Cathode resistor	$R_k$	1.2	1.2	1.2	1.2	1.2	k $\Omega$
Grid resistor	$R_{g'}$	0.15	0.15	0.15	0.15	0.15	M $\Omega$
Anode current	$I_a$	1.86	2.45	3.15	3.80	4.40	mA
Voltage gain	$V_o/V_i$	18.5	18.5	18.5	18.5	18.5	
Output voltage at $+I_g = 0.3 \mu A$	$V_o$	20	30	40	50	60	V <sub>RMS</sub>
Total distortion 1)	$d_{tot}$	3.3	3.8	4.0	4.1	4.2	%
Anode supply voltage	$V_{ba}$	200	250	300	350	400	V
Anode resistor	$R_a$	100	100	100	100	100	k $\Omega$
Cathode resistor	$R_k$	2.2	2.2	2.2	2.2	2.2	k $\Omega$
Grid resistor	$R_{g'}$	0.33	0.33	0.33	0.33	0.33	M $\Omega$
Anode current	$I_a$	1.00	1.30	1.65	1.95	2.30	mA
Voltage gain	$V_o/V_i$	20	20	20	20	20	
Output voltage at $+I_g = 0.3 \mu A$	$V_o$	22	32	42	52	63	V <sub>RMS</sub>
Total distortion 1)	$d_{tot}$	3.1	3.4	3.5	3.6	3.7	%
Anode supply voltage	$V_{ba}$	200	250	300	350	400	V
Anode resistor	$R_a$	220	220	220	220	220	k $\Omega$
Cathode resistor	$R_k$	3.9	3.9	3.9	3.9	3.9	k $\Omega$
Grid resistor	$R_{g'}$	0.68	0.68	0.68	0.68	0.68	M $\Omega$
Anode current	$I_a$	0.52	0.67	0.83	0.99	1.15	mA
Voltage gain	$V_o/V_i$	21	21	21	21	21	
Output voltage at $+I_g = 0.3 \mu A$	$V_o$	19	29	38	47	58	V <sub>RMS</sub>
Total distortion 1)	$d_{tot}$	2.3	2.6	3.0	3.1	3.2	%

1) At lower output voltages the distortion is proportionally lower.

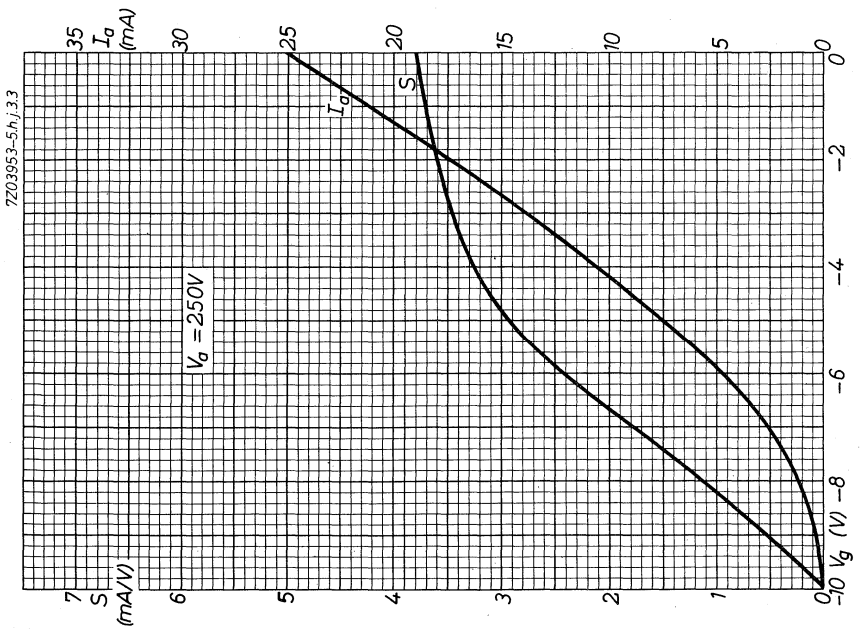
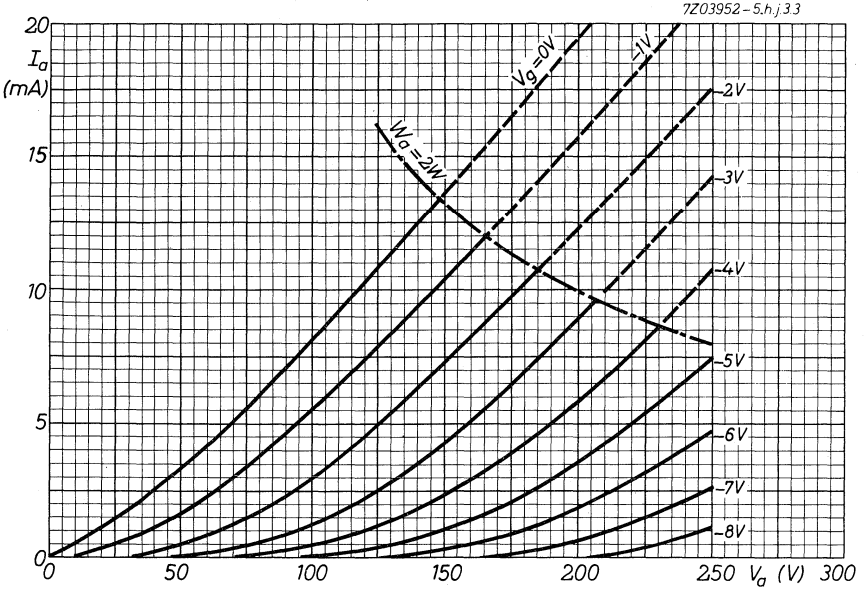

## S.Q. TUBE

Special quality triode-pentode

The pentode section is designed for use as mixer and R.F. or A.F. amplifier. The triode section is designed for use as oscillator (max. freq. 300 MHz) multivibrator or blocking oscillator.

### QUICK REFERENCE DATA

Life test	10 000 hours	
Low interface resistance		
Mechanical quality	Shock and vibration resistant	
Base	Noval. Gold plated pins	
Heating	Indirect A.C. or D.C.; parallel supply	
Heater voltage	$V_f$	6.3 V
Heater current	$I_f$	330 mA
Pentode: Anode current	$I_a$	10 mA
Mutual conductance	S	6.2 mA/V
Amplification factor	$\mu$	40
Triode: Anode current	$I_a$	14 mA
Mutual conductance	S	5 mA/V
Amplification factor	$\mu$	18

### DIMENSIONS AND CONNECTIONS

Dimensions in mm

Base: Noval

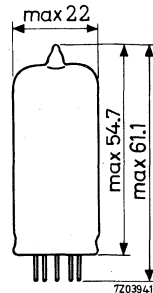
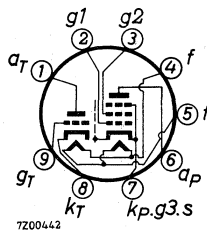

## CHARACTERISTICS

- Column I Nominal value or setting of the tube  
 II Range values for equipment design: Initial spread  
 III Range values for equipment design: End of life

		I	II	III	
Heater voltage	$V_f$	6.3			V
Heater current	$I_f$	330	313 - 347		mA
<u>Pentode section</u>					
Anode supply voltage	$V_{ba}$	170			V
Grid No.2 supply voltage	$V_{bg_2}$	170			V
Cathode resistor	$R_k$	155			$\Omega$
Anode current	$I_a$	10	7.5 - 12.5	min. 6	mA
Grid No.2 current	$I_{g_2}$	2.8	1.55 - 4.05		mA
Mutual conductance	S	6.2	5.2 - 7.2	min. 4.3	mA/V
Amplification factor grid No.2 to grid No.1	$\mu_{g_2g_1}$	40			
Internal resistance	$R_i$	0.4	min. 0.26		M $\Omega$
Negative grid No.1 current	$-I_{g_1}$		max. 0.5	max. 1.0	$\mu A$
<u>Triode section</u>					
Anode supply voltage	$V_{ba}$	100			V
Cathode resistor	$R_k$	120			$\Omega$
Anode current	$I_a$	14	10 - 18	min. 8.4	mA
Mutual conductance	S	5.0	4 - 6	min. 3.5	mA/V
Amplification factor	$\mu$	18			
Negative grid current	$-I_g$		max. 0.5	max. 1.0	$\mu A$

**CAPACITANCES** Without external shieldPentodeGrid No.1 to grid No.2, grid No.3  
cathode, heater and screen $C_{g1/g2g3kfs}$ 

I

5.6

II

5.2 - 6

pF

Anode to grid No.2, grid No.3  
cathode, heater and screen $C_{a/g2g3kfs}$ 

3.4

3 - 3.8

pF

Anode to grid No.1

 $C_{ag1}$ 

max. 25

mpF

Grid No.1 to heater

 $C_{g1f}$ 

max.0.16

pF

TriodeGrid to cathode (triode), cathode (pentode)  
grid No.3, heater and screen $C_{g/k_Tk_pg3fs}$ 

2.5

2.2 - 2.8

pF

Anode to cathode (triode), cathode (pentode)  
grid No.3, heater and screen $C_{a/k_Tk_pg3fs}$ 

1.5

1.2 - 1.8

pF

Anode to grid

 $C_{ag}$ 

1.5

1.2 - 1.8

pF

Grid to heater

 $C_{gf}$ 

max.0.22

pF

Pentode to triode

Anode (pentode) to anode (triode)

 $C_{aP-aT}$ 

max.0.07

pF

Anode (pentode) to grid (triode)

 $C_{aP-gT}$ 

max.0.02

pF

Grid No.1 (pentode) to anode (triode)

 $C_{g1P-aT}$ 

max.0.16

pF

**MICROPHONY**

The pentode section can be used without special precautions against microphony in circuits where an input voltage of more than 50 mV is required for an output of 50 mW.

**SHOCK AND VIBRATION RESISTANCE**

The following test conditions are applied to assess the mechanical quality of the tube. These conditions are not intended to be used as normal operating conditions.

Shock

The tube is subjected 5 times in each of 4 positions to an acceleration of 500 g supplied by an NRL shock machine with the hammer lifted over an angle of 30°.

Vibration

The tube is subjected during 32 hours in each of 3 positions to a vibration frequency of 50 Hz with an acceleration of 2.5 g.

**LIFE**

Production samples are tested to be within the end of life values (column III) under the following conditions during 10 000 hours.

Pentode section

$$V_{ba} = 170 \text{ V}$$

$$V_{bg_2} = 170 \text{ V}$$

$$R_k = 155 \ \Omega$$

Triode section

$$V_{ba} = 100 \text{ V}$$

$$R_k = 120 \ \Omega$$

**LIMITING VALUES** (Absolute max. rating system)Pentode section

Anode voltage	$V_{a_0}$	max. 550 V
	$V_a$	max. 275 V
Anode dissipation	$W_a$	max. 2.15 W
Grid No.2 voltage	$V_{g_{20}}$	max. 550 V
Grid No.2 voltage:		
Cathode current > 10 mA	$V_{g_2}$	max. 200 V
Cathode current < 10 mA	$V_{g_2}$	max. 225 V
Grid No.2 dissipation:		
Anode dissipation > 1.2 W	$W_{g_2}$	max. 0.7 W
Anode dissipation < 1.2 W	$W_{g_2}$	max. 0.8 W
Grid No.1 dissipation	$W_{g_1}$	max. 0.1 W
Negative grid No.1 voltage	$-V_{g_1}$	max. 100 V
Cathode current	$I_k$	max. 18 mA
Voltage between cathode and heater	$V_{kf}$	max. 100 V
Grid resistor (fixed bias)	$R_{g_1}$	max. 0.5 M $\Omega$

**LIMITING VALUES** (Absolute max. rating system) (continued)Triode section

Anode voltage	$V_{a0}$	max. 550 V
	$V_a$	max. 275 V
Anode dissipation	$W_a$	max. 1.75 W
Grid dissipation	$W_g$	max. 0.1 W
Grid, voltage, peak value	$V_{gp}$	max. 30 V
Duty factor max. 0.04		
Pulse duration max. 0.8 ms		
Grid voltage	$-V_g$	max. 100 V
Cathode current	$I_k$	max. 18 mA
Cathode current peak value	$I_{kp}$	max. 100 mA
Duty factor max. 0.04		
Pulse duration max. 0.8 ms		
Voltage between cathode and heater	$V_{kf}$	max. 100 V
Grid resistor (fixed bias)	$R_g$	max. 0.5 M $\Omega$
Bulb temperature	$t_{bulb}$	max. 170 °C

Heater voltage: The average heater voltage should be 6.3 V.

Variation of the heater voltage exceeding the range of 6.0 V to 6.6 V will shorten the tube life.

The tolerance of heater current (column II) should be taken into account.



## OPERATING CHARACTERISTICS

### Pentode section as R.F. amplifier

Anode supply voltage	$V_{ba}$	170 V
Grid No.2 supply voltage	$V_{bg_2}$	170 V
Cathode resistor	$R_k$	155 $\Omega$
Anode current	$I_a$	10 mA
Grid No.2 current	$I_{g_2}$	2.8 mA
Mutual conductance	$S$	6.2 mA/V
Amplification factor grid No.2 to grid No.1	$\mu_{g_2g_1}$	40
Internal resistance	$R_i$	0.4 $M\Omega$
Input resistance at 50 MHz	$r_{g_1}$	10 $k\Omega$
Equivalent noise resistance	$R_{eq}$	1.5 $k\Omega$

### Pentode section as mixer

Anode supply voltage	$V_{ba}$	170 V
Grid No.2 supply voltage	$V_{bg_2}$	170 V
Grid No.1 resistor	$R_{g_1}$	0.1 $M\Omega$
Cathode resistor	$R_k$	330 $\Omega$
Oscillator voltage	$V_{osc}$	3.5 $V_{RMS}$
Anode current	$I_a$	8 mA
Grid No.2 current	$I_{g_2}$	2.5 mA
Grid No.1 current	$I_{g_1}$	12 $\mu A$
Conversion conductance	$S_c$	2.4 mA/V
Internal resistance	$R_i$	0.5 $M\Omega$

### Triode as oscillator

Operation in Colpitts circuit is recommended.

Operation in Hartley circuit is not recommended.



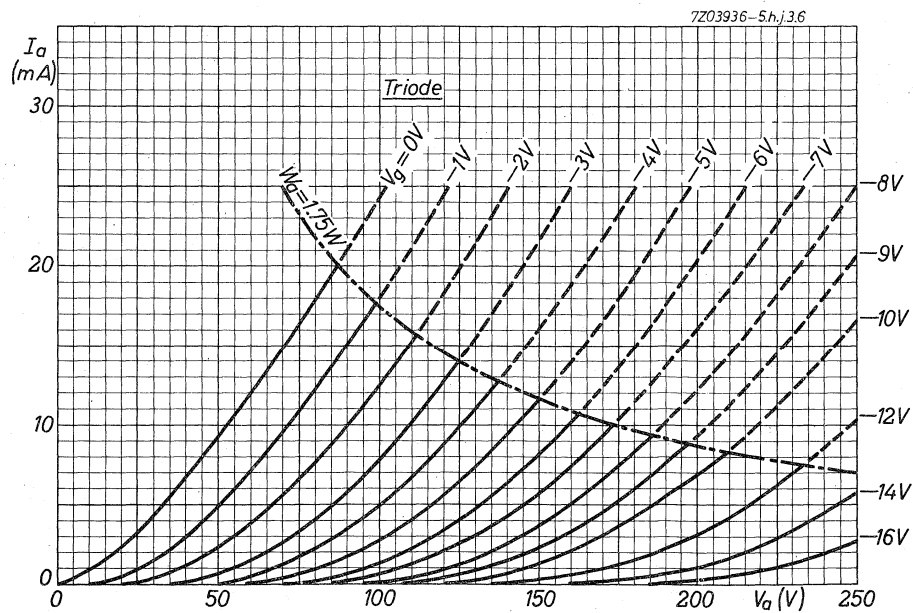
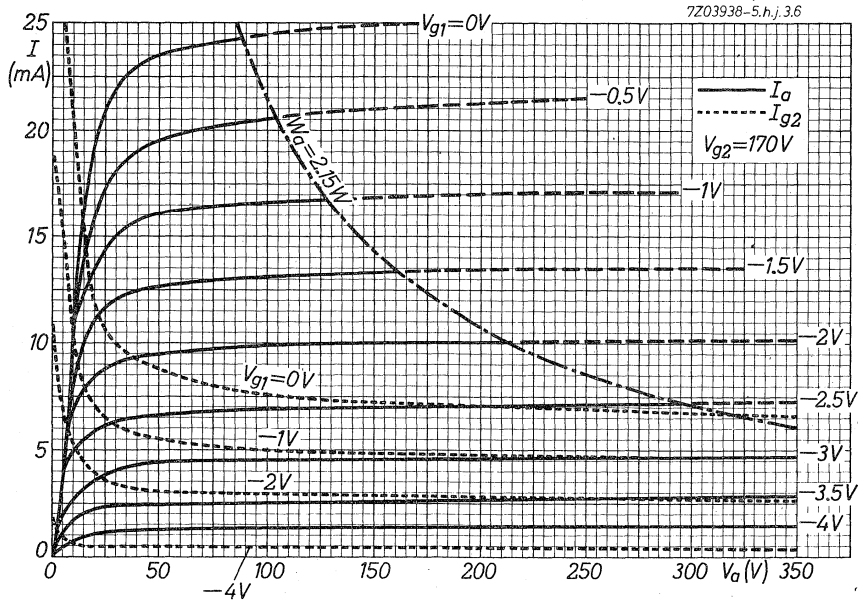

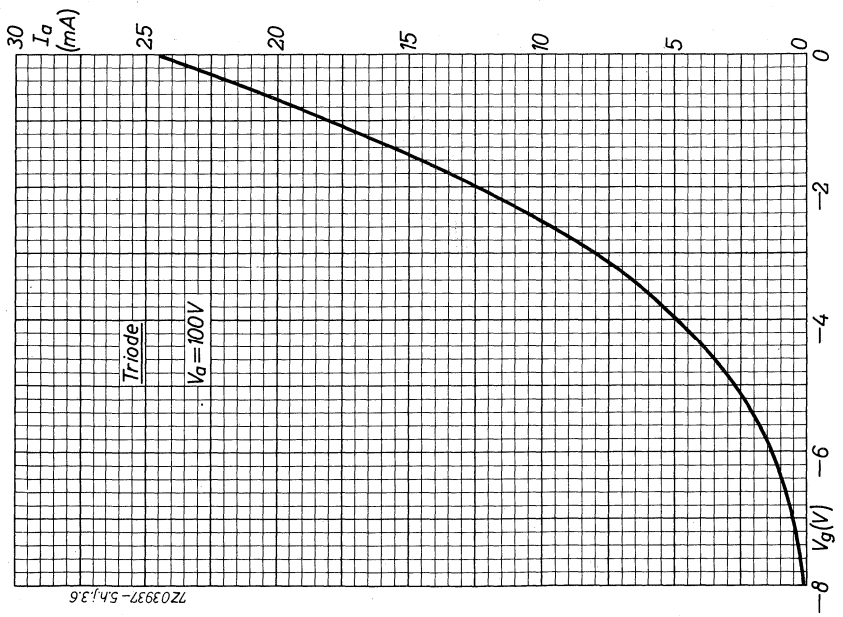
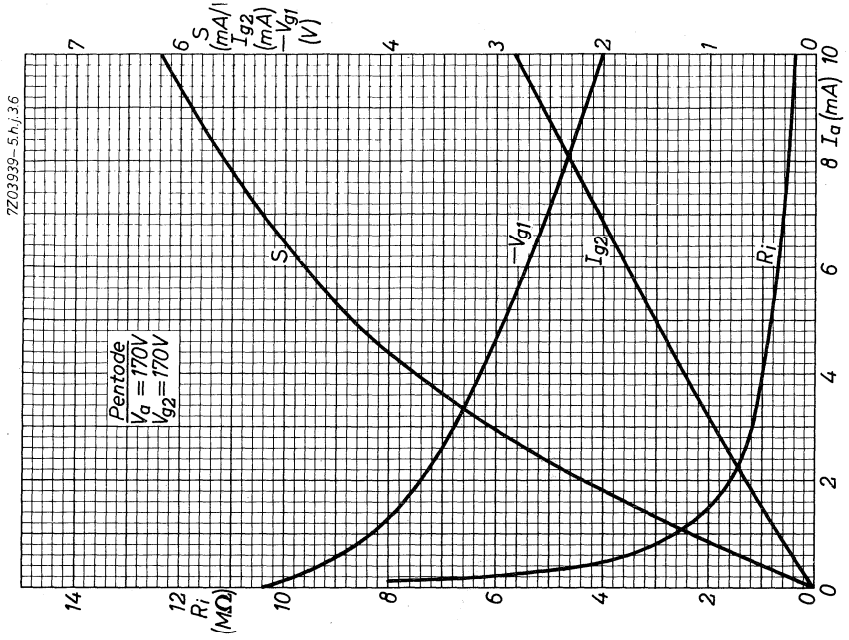

## S.Q. TUBE

Special quality pentode designed for use as amplifier.

QUICK REFERENCE DATA	
Life test	10 000 hours
Low interface resistance	
Mechanical quality	Shock and vibration resistant
Base	Noval. Gold plated pins
Heating	Indirect A.C. or D.C. Series or parallel supply
Heater voltage	$V_f$ 6.3 V
Heater current	$I_f$ 300 mA
Anode current	$I_a$ 3 mA
Mutual conductance	$S$ 1.85 mA/V
Equivalent noise resistance (A.F.)	$R_{eq}$ 40 k $\Omega$
Hum voltage	$V_{g1}$ max. 5 $\mu V_{RMS}$

### DIMENSIONS AND CONNECTIONS

Dimensions in mm

Base: Noval

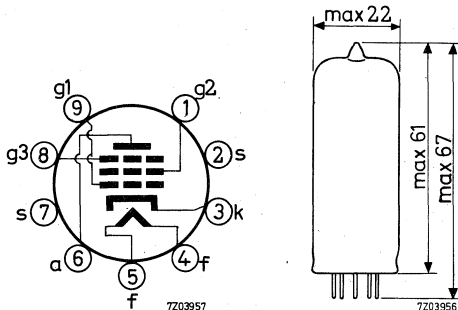

**CHARACTERISTICS**

Column I Nominal value or setting of the tube

II Range values for equipment design: Initial spread

III Range values for equipment design: End of life

		I	II	III	
Heater voltage	$V_f$	6.3			V
Heater current	$I_f$	300	285- 315		mA
Anode voltage	$V_a$	250			V
Grid No.3 voltage	$V_{g_3}$	0			V
Grid No.2 voltage	$V_{g_2}$	100			V
Cathode resistor	$R_k$	550			$\Omega$
Anode current	$I_a$	3	2.5- 3.5	min. 2.0	mA
Grid No.2 current	$I_{g_2}$	0.65	0.45-0.85	min. 0.35	mA
Mutual conductance	S	1.85	1.5- 2.2	min. 1.2	mA/V
Internal resistance	$R_i$	1.5	min. 1.0		M $\Omega$
Amplification factor grid No.2 to grid No.1	$\mu_{g_2g_1}$	25			
<u>Equivalent noise resistance</u>	$R_{eq}$		max. 40		k $\Omega$
Frequency 0-10 kHz					
Grid No.1 resistor $R_{g_1} = 0 \Omega$					
<u>Negative grid No.1 current</u>	$-I_{g_1}$		max. 0.1	max. 0.2	$\mu A$
<u>Cut off voltage</u>	$-V_{g_1}$	7.5			V
Anode voltage	$V_a$	250			V
Grid No.3 voltage	$V_{g_3}$	0			V
Grid No.2 voltage	$V_{g_2}$	100			V
Anode current	$I_a$		max. 20		$\mu A$
<u>Hum voltage</u>	$V_{g_1}$		max. 5		$\mu V_{RMS}$
Grid resistor $R_{g_1} = 1 M\Omega$					
Cathode resistor bypassed					
<u>Leakage current between cathode and heater</u>			max. 12		$\mu A$

Voltage between cathode and  
heater  $V_{kf} = 120 V$

**CAPACITANCES** With external shield

	I	II	
Anode to grid No.2, grid No.3, cathode and heater	$C_{a/g_2g_3kf}$ 7.3	6.8-7.8	pF
Grid No.1 to grid No.2, grid No.3, cathode and heater	$C_{g_1/g_2g_3kf}$ 5.0	4.5-5.5	pF
Anode to grid No.1	$C_{ag_1}$	max. 25	mpF
Grid No.1 to heater	$C_{g_1f}$	max. 2	mpF
Cathode to heater	$C_{kf}$ 3.7		pF

**SHOCK AND VIBRATION RESISTANCE**

The following test conditions are applied to assess the mechanical quality of the tube. These conditions are not intended to be used as normal operating conditions.

Shock

The tube is subjected 5 times in each of 4 positions to an acceleration of 500 g supplied by an NRL shock machine with the hammer lifted over an angle of 30°.

Vibration

The tube is subjected during 32 hours in each of 3 positions to a vibration frequency of 50 Hz with an acceleration of 2.5 g.

**LIFE**

Production samples are tested to be within the end of life values (column III) under the following conditions during 10 000 hours.

Anode voltage	$V_a$	250	V
Grid No.3 voltage	$V_{g_3}$	0	V
Grid No.2 voltage	$V_{g_2}$	100	V
Cathode resistor	$R_k$	550	$\Omega$

## LIMITING VALUES (Absolute max. rating system)

Anode voltage	$V_{a0}$ $V_a$	max. 600 V max. 300 V
Anode dissipation	$W_a$	max. 1.3 W
Grid No.2 voltage	$V_{g2_0}$ $V_{g2}$	max. 600 V max. 200 V
Grid No.2 dissipation	$W_{g2}$	max. 0.4 W
Negative grid No.3 voltage	$-V_{g3}$	max. 100 V
Negative grid No.1 voltage	$-V_{g1}$	max. 100 V
Cathode current	$I_k$	max. 9 mA
Voltage between cathode and heater		
Cathode positive	$V_{kf}$ (k pos)	max. 120 V
Cathode negative	$V_{kf}$ (k neg)	max. 60 V
Grid No.1 resistor	$R_{g1}$	See curve on page G
Bulb temperature		max. 170 °C

Heater voltage: The average heater voltage should be 6.3 V.

Variations of the heater voltage exceeding the range of 6.0 V to 6.6 V will shorten the tube life.

The tolerance of heater current (column II) should be taken into account.

## OPERATING CHARACTERISTICS

Resistance coupled A.F. amplifier

Anode supply voltage	$V_{ba}$	100	200	250	300	400	V
Grid No.2 supply voltage	$V_{bg_2}$	100	200	250	300	400	V
Anode resistor	$R_a$	0.22	0.22	0.22	0.22	0.22	M $\Omega$
Grid No.2 resistor	$R_{g_2}$	1.0	1.2	1.2	1.2	1.2	M $\Omega$
Cathode resistor	$R_k$	3.3	1.8	1.5	1.2	1.0	k $\Omega$
Grid No.1 resistor	$R_{g_1}$	1	1	1	1	1	M $\Omega$
Grid resistor next stage	$R_{g_1'}$	0.68	0.68	0.68	0.68	0.68	M $\Omega$
Anode current	$I_a$	0.29	0.61	0.80	0.98	1.37	mA
Grid No.2 current	$I_{g_2}$	0.07	0.13	0.17	0.20	0.28	mA
Gain	$V_o/V_i$	120	165	175	190	200	
Output voltage at $+I_g = 0.3 \mu A$	$V_o$	8	20	25	30	40	V <sub>RMS</sub>
Total distortion	$d_{tot}$	1.7	1.6	1.4	1.1	0.9	%

Electrometer pentode

Heater voltage	$V_f$	4.5	V
Anode voltage	$V_a$	40	V
Grid No.3 voltage	$V_{g_3}$	0	V
Grid No.2 voltage	$V_{g_2}$	40	V
Negative grid No.1 voltage	$-V_{g_1}$	2.15	V
Anode current	$I_a$	40	$\mu A$
Grid No.2 current	$I_{g_2}$	9	$\mu A$
Negative grid No.1 current	$-I_{g_1}$	max. $10^{-10}$	A

7Z03964-5.h.j.6

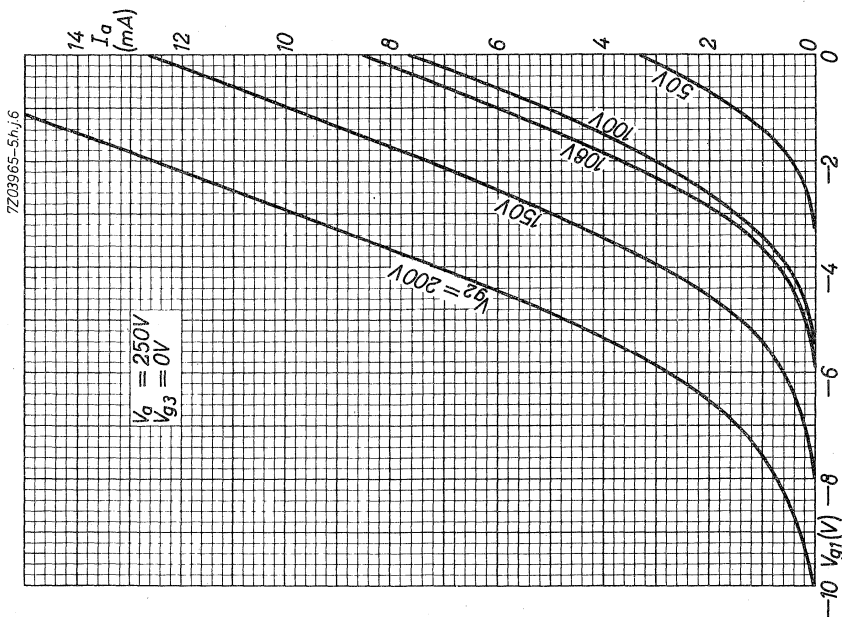
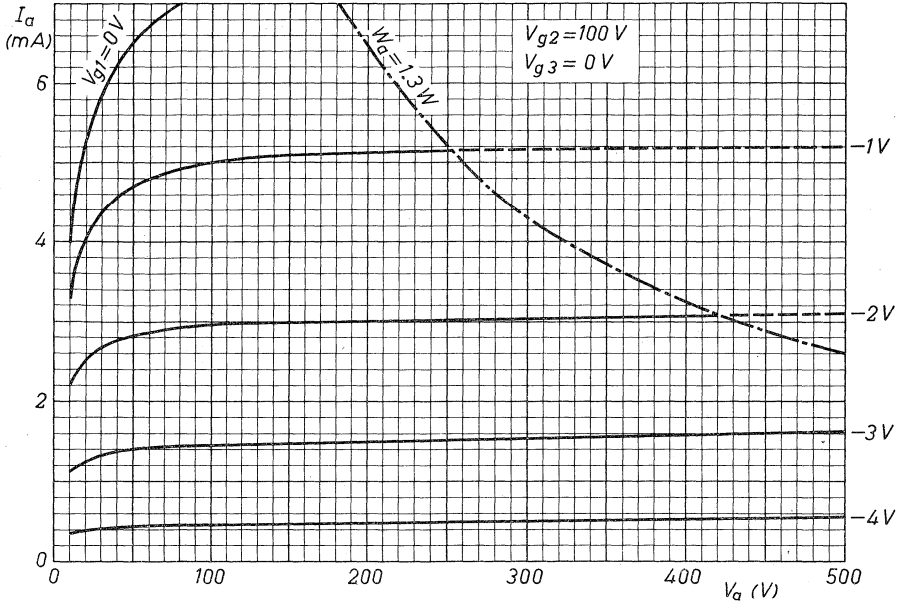



## S.Q. TUBE

Special quality output pentode

## QUICK REFERENCE DATA

Life test	10 000 hours	
Low interface resistance		
Mechanical quality	Shock and vibration resistant	
Base	Noval. Gold plated pins	
Heating	Indirect A. C. or D. C. Series or parallel supply	
Heater voltage	$V_f$	6.3 V
Heater current	$I_f$	700 mA
Anode current	$I_a$	30 mA
Output power, one tube	$W_o$	2.7 W
two tubes class AB	$W_o$	5.7 W

## DIMENSIONS AND CONNECTIONS

Dimensions in mm

Base: Noval

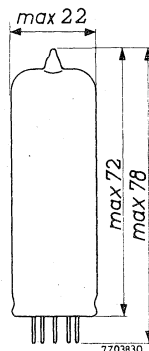
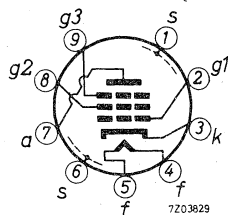

## CHARACTERISTICS

Column I Nominal value or setting of the tube

II Range values for equipment design: Initial spread

III Range values for equipment design: End of life

		I	II	III	
Heater voltage	$V_f$	6.3			V
Heater current	$I_f$	700	665 - 735		mA
Anode voltage	$V_a$	200			V
Grid No. 3 voltage	$V_{g3}$	0			V
Grid No. 2 voltage	$V_{g2}$	200			V
Cathode resistor	$R_k$	130			$\Omega$
Anode current	$I_a$	30	26.5 - 33.5	min. 21	mA
Grid No. 2 current	$I_{g2}$	4.1	2.7 - 5.5	min. 2.0	mA
Mutual conductance	$S$	9.0	7.4 - 10.6	min. 6.0	mA/V
Amplification factor grid No. 2 to grid No. 1	$\mu_{g2g1}$	21.5			
Negative grid No. 1 current	$-I_{g1}$		max. 0.5	max. 1.0	$\mu A$
Anode voltage	$V_a$	200			V
Grid No. 3 voltage	$V_{g3}$	0			V
Grid No. 2 voltage	$V_{g2}$	200			V
Anode current	$I_a$	30			mA
Load resistance	$R_{a\sim}$	7			k $\Omega$
Output power	$W_o$	2.7	min. 2.0		W
<u>Cut-off voltage</u>	$-V_{g1}$	14			V
Anode voltage	$V_a$	200			V
Grid No. 3 voltage	$V_{g3}$	0			V
Grid No. 2 voltage	$V_{g2}$	200			V
Anode current	$I_a$		max. 0.2		mA

**CHARACTERISTICS** (continued)

Hum voltage

Grid No.1 resistor  $R_{g1} = 0.5 \text{ M}\Omega$

Cathode resistor by-passed

Leakage current between cathode and heater

Voltage between cathode and heater  $V_{kf} = 120 \text{ V}$

Insulation resistance between two electrodes

Voltage between electrodes = 300 V

	I	II	III	
$V_{g1}$		max. 0.25		mVRMS
$I_{kf}$		max. 15	max. 20	$\mu\text{A}$
R		min. 50	min. 10	$\text{M}\Omega$

**CAPACITANCES**

Grid No.1 to grid No.3, grid No.2, cathode heater and screen

Anode to grid No.3, grid No.2, cathode heater and screen

Anode to grid No.1

Grid No.1 to heater

Cathode to heater

	I	II	
$C_{g1/g3g2kfs}$	10	9.2 - 10.8	pF
$C_{a/g3g2kfs}$	6.8	6.3 - 7.3	pF
$C_{ag1}$		max. 0.15	pF
$C_{g1f}$		max. 0.25	pF
$C_{kf}$	7.0		pF

**SHOCK AND VIBRATION RESISTANCE**

The following test conditions are applied to assess the mechanical quality of the tube. These conditions are not intended to be used as normal operating conditions.

Shock

The tube is subjected 5 times in each of 4 positions to an acceleration of 500 g supplied by an NRL shock machine with the hammer lifted over an angle of 30°.

Vibration

The tube is subjected during 32 hours in each of 3 positions to a vibration frequency of 50 Hz with an acceleration of 2.5 g.

**LIFE**

Production samples are tested to be within the end of life values (column III) under the following conditions during 10 000 hours.

Anode voltage	$V_a$	200	V
Grid No.3 voltage	$V_{g_3}$	0	V
Grid No.2 voltage	$V_{g_2}$	200	V
Cathode resistor	$R_k$	130	$\Omega$

**LIMITING VALUES** (Absolute max. rating system)

Anode voltage	$V_{a_0}$	max.	600	V
	$V_a$	max.	300	V
Anode dissipation	$W_a$	max.	8	W
Negative grid No.3 voltage	$-V_{g_3}$	max.	100	V
Grid No.2 voltage	$V_{g_{20}}$	max.	600	V
	$V_{g_2}$	max.	300	V
Grid No.2 dissipation	$W_{g_2}$	max.	2.6	W
Grid No.1 voltage	$-V_{g_1}$	max.	100	V
Cathode current	$I_k$	max.	50	mA
Voltage between cathode and heater	$V_{kf}$	max.	120	V
Bulb temperature	$t_{bulb}$	max.	225	$^{\circ}\text{C}$
Grid No.1 resistor (automatic bias)	$R_{g_1}$	max.	1	M $\Omega$

Heater voltage: The average heater voltage should be 6.3 V.

Variations of the heater voltage exceeding the range of 6.0 V to 6.6 V will shorten the tube life.

The tolerance of heater current (column II) should be taken into account.

## OPERATING CHARACTERISTICS

Output tube class A

Anode voltage	$V_a$	200	250	V
Grid No.3 voltage	$V_{g3}$	0	0	V
Grid No.2 voltage	$V_{g2}$	200	250	V
Grid No.2 resistor	$R_{g2}$		1	$k\Omega$
Cathode resistor	$R_k$	130	270	$\Omega$
Anode current	$I_a$	30	24	mA
Grid No.2 current	$I_{g2}$	4.1	3.3	mA
Mutual conductance	$S$	9	-	mA/V
Internal resistance	$R_i$	52	-	$k\Omega$
Load resistance	$R_{a\sim}$	7	10	$k\Omega$
Output power	$W_o$	2.7	2.8	W
Total distortion	$d_{tot}$	10	10	%

Output tube class AB (two tubes)

Anode voltage	$V_a$	200		V
Grid No.3 voltage	$V_{g3}$	0		V
Grid No.2 voltage	$V_{g2}$	200		V
Cathode resistor	$R_k$	130		$\Omega$
Load resistance	$R_{aa\sim}$	9		$k\Omega$
Input voltage	$V_i$	0	0.31	5.2 VRMS
Anode current	$I_a$	2x20.6	-	2x24.6 mA
Grid No.2 current	$I_{g2}$	2x2.8	-	2x4.9 mA
Output power	$W_o$	0	0.05	5.7 W
Total distortion	$d_{tot}$	-	-	3.0 %

**OPERATING CHARACTERISTICS (continued)**

Output tube class AB (two tubes)

Anode voltage	$V_a$	250	V
Grid No.3 voltage	$V_{g3}$	0	V
Grid No.2 voltage	$V_{g2}$	250	V
Cathode resistor	$R_k$	150	$\Omega$
Load resistance	$R_{aa\sim}$	9	$k\Omega$
Input voltage	$V_i$	0   0.32   7.8	$V_{RMS}$
Anode current	$I_a$	2x23.5   -   2x29.5	mA
Grid No.2 current	$I_{g2}$	2x3.2   -   2x6.6	mA
Output power	$W_o$	0   0.05   9	W
Total distortion	$d_{tot}$	-	4.5 %

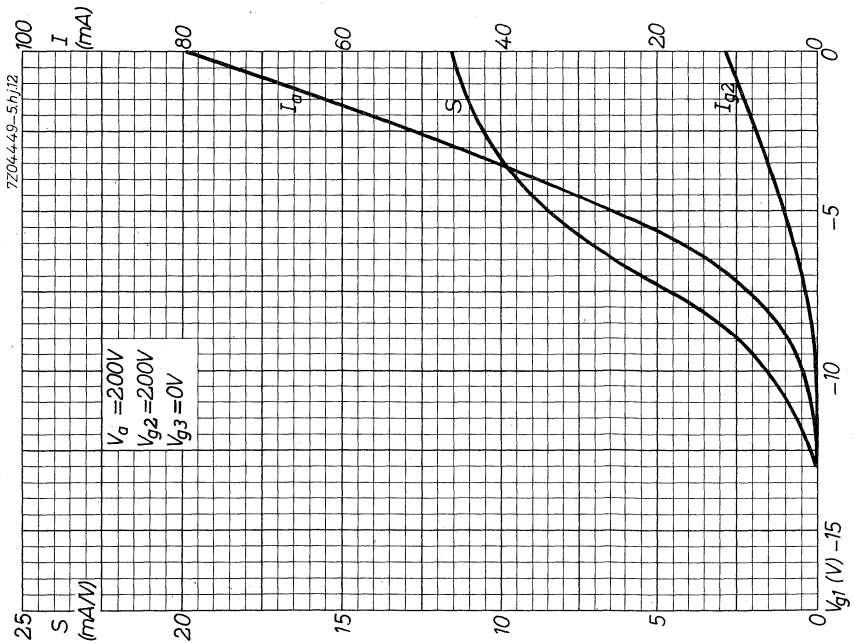
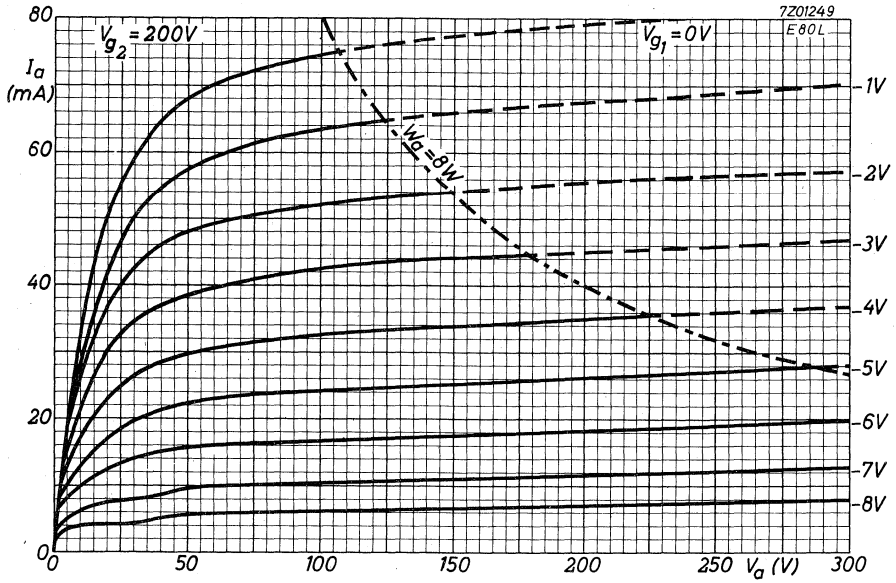

# E80L

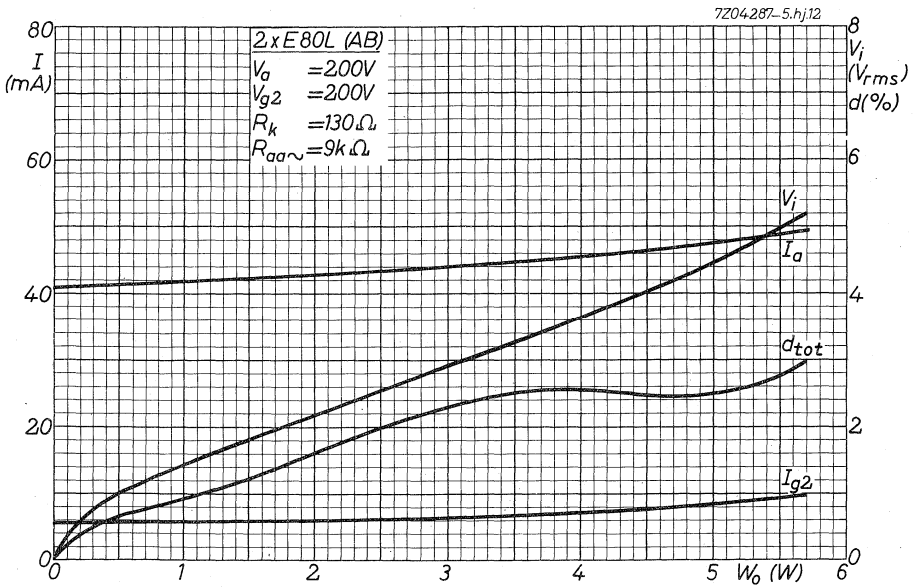
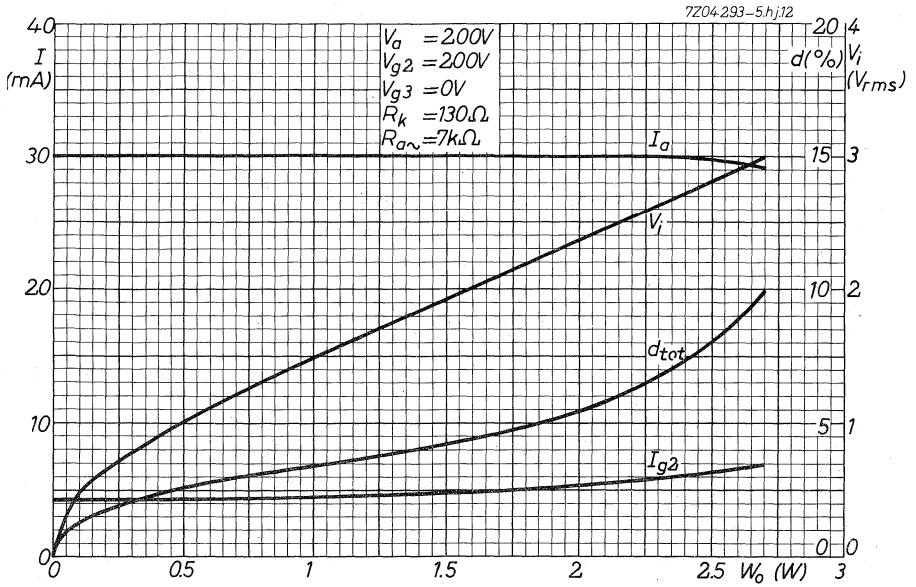



## S.Q. TUBE

Special quality output pentode designed for use in telephone equipment.

### QUICK REFERENCE DATA

Life test	10 000 hours	
Base	Noval. Gold plated pins	
Heating	Indirect a.c. or d.c. Series or parallel supply	
Heater voltage	$V_f$	6.3 V
Heater current	$I_f$	375 mA
Anode current	$I_a$	20 mA
Output power	$W_o$	1 W

### DIMENSIONS AND CONNECTIONS

Dimensions in mm

Base: Noval

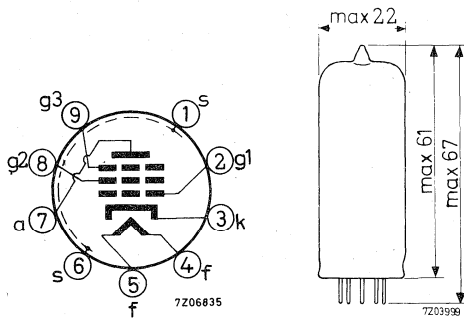

**CHARACTERISTICS**

Column I Nominal value or setting of the tube

II Range values for equipment design: Initial spread

III Range values for equipment design: End of life

		I	II	III	
Heater voltage	$V_f$	6.3			V
Heater current	$I_f$	375	355- 395		mA
Anode voltage	$V_a$	210			V
Grid No.3 voltage	$V_{g_3}$	0			V
Grid No.2 voltage	$V_{g_2}$	210			V
Cathode resistor	$R_k$	120			$\Omega$
Anode current	$I_a$	20	17- 23	min. 13.5	mA
Grid No.2 current	$I_{g_2}$	5.3	4.1- 6.5	min. 3.1	mA
Mutual conductance	S	11	9.5-12.5	min. 7.8	mA/V
Internal resistance	$R_i$	0.3	min. 0.2		$M\Omega$
Amplification factor grid No.2 to grid No.1	$\mu_{g_2g_1}$	36			
Equivalent noise resistance	$R_{eq}$	1.2			$k\Omega$
<u>Negative grid current</u>	$-I_{g_1}$		max. 0.5	max. 1.0	$\mu A$
<u>Hum voltage</u>	$V_{g_1}$		max. 0.2		mV <sub>RMS</sub>
Grid resistor $R_{g_1} = 0.5 M\Omega$ Heater centre earthed Cathode resistor bypassed					
<u>Leakage current between cathode and heater</u>	$I_{kf}$		max. 24		$\mu A$
Voltage between cathode and heater $V_{kf} = 120 V$					

**CAPACITANCES**

	I	II	
Anode to grid No.3, grid No.2 cathode heater and screen	$C_{a/g_3g_2kfs}$	6.5	5.9 - 7.1 pF
Grid No.1 to grid No.3, grid No.2 cathode heater and screen	$C_{g_1/g_3g_2kfs}$	11.2	10.4 - 12 pF
Grid No.1 to grid No.3, grid No.2 cathode heater and screen Measured with cathode current $I_k = 25$ mA	$C_{g_1/g_3g_2kfs}$	14.3	pF
Anode to grid No.1	$C_{ag_1}$		max. 0.02 pF
Grid No.1 to heater	$C_{g_1f}$		max. 0.2 pF
Cathode to heater	$C_{kf}$	4.2	pF

**SHOCK AND VIBRATION RESISTANCE**

The following test conditions are applied to assess the mechanical quality of the tube. These conditions are not intended to be used as normal operating conditions.

Shock

The tube is subjected 5 times in each of 4 positions to an acceleration of 500 g supplied by an NRL shock machine with the hammer lifted over an angle of 30°.

Vibration

The tube is subjected during 32 hours in each of 3 positions to a vibration frequency of 50 Hz with an acceleration of 2.5 g.

**LIFE**

Production samples are tested to be within the end of life values (column III) under the following conditions during 10,000 hours.

Anode voltage	$V_a$	210	V
Grid No.3 voltage	$V_{g_3}$	0	V
Grid No.2 voltage	$V_{g_2}$	210	V
Cathode resistor	$R_k$	120	$\Omega$

## LIMITING VALUES (Design centre rating system)

Anode voltage	$V_{a_0}$	max.	550 V
	$V_a$	max.	210 V
Anode dissipation	$W_a$	max.	4.5 W
Grid No.2 voltage	$V_{g_{20}}$	max.	550 V
	$V_{g_2}$	max.	210 V
Grid No.2 dissipation	$W_{g_2}$	max.	1.2 W
Cathode current	$I_k$	max.	30 mA
Grid No.1 resistor:			
automatic bias	$R_{g_1}$	max.	0.5 M $\Omega$
fixed bias	$R_{g_1}$	max.	0.25 M $\Omega$
Voltage between cathode and heater	$V_{kf}$	max.	120 V
Bulb temperature	$t_{bulb}$	max.	170 °C

Heater voltage: The average heater voltage should be 6.3 V. Variations of the heater voltage exceeding the range of 6.0 V to 6.6 V will shorten the tube life. The tolerance of heater current (column II) should be taken into account.

## OPERATING CHARACTERISTICS

### Output tube, Class A

Anode voltage	$V_a$	210 V
Grid No.3 voltage	$V_{g_3}$	0 V
Grid No.2 voltage	$V_{g_2}$	210 V
Cathode resistor	$R_k$	120 $\Omega$
Load resistance	$R_{a\sim}$	15 k $\Omega$
Anode current	$I_a$	20 mA
Grid No.2 current	$I_{g_2}$	5.3 mA
Output power	$W_o$	1 W
Total distortion	$d_{tot}$	5 %

OPERATING CHARACTERISTICS (continued)

Amplifier

Anode voltage	$V_a$	210 V
Grid No.3 voltage	$V_{g3}$	0 V
Grid No.2 voltage	$V_{g2}$	210 V
Cathode resistor	$R_k$	180 $\Omega$
Load resistance	$R_{a\sim}$	20 k $\Omega$
Anode current	$I_a$	15 mA
Grid No.2 current	$I_{g2}$	4 mA
Voltage gain	$V_o/V_i$	5.15 N

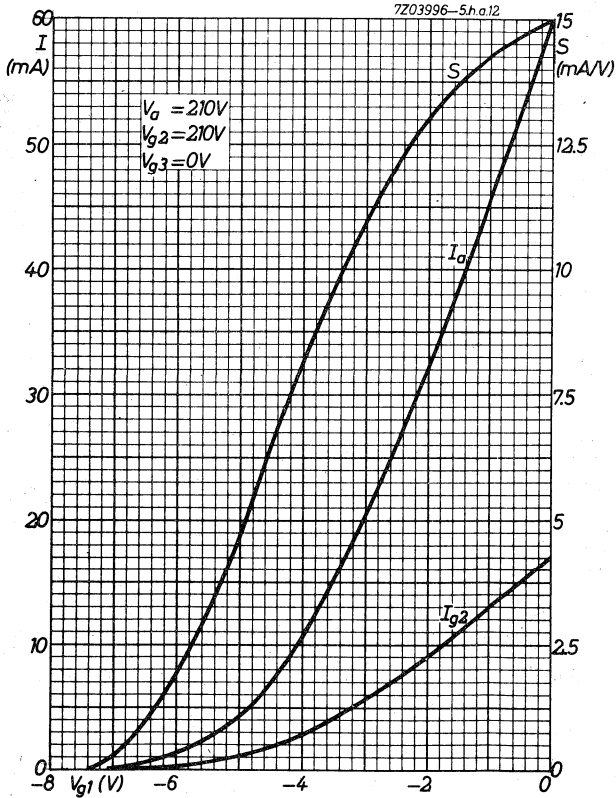

7203993-5.h.a.12

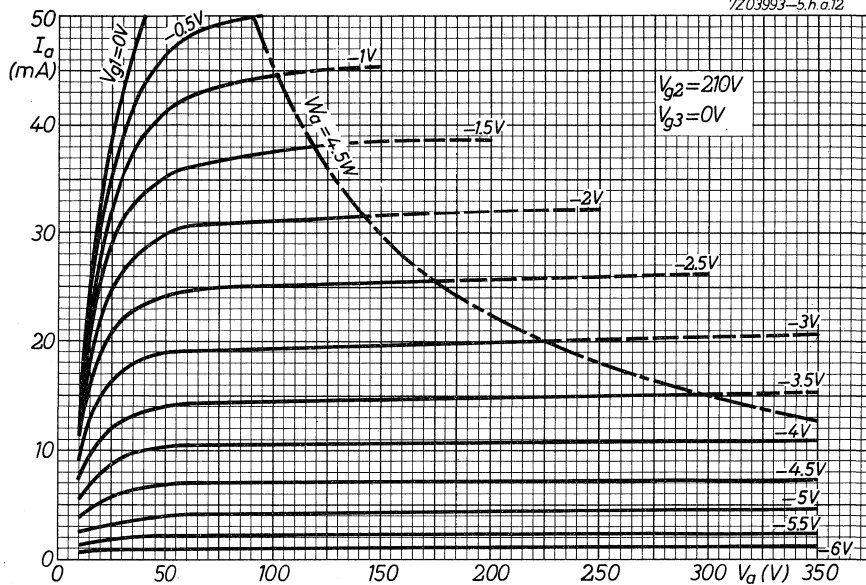

7203995-5.h.a.12

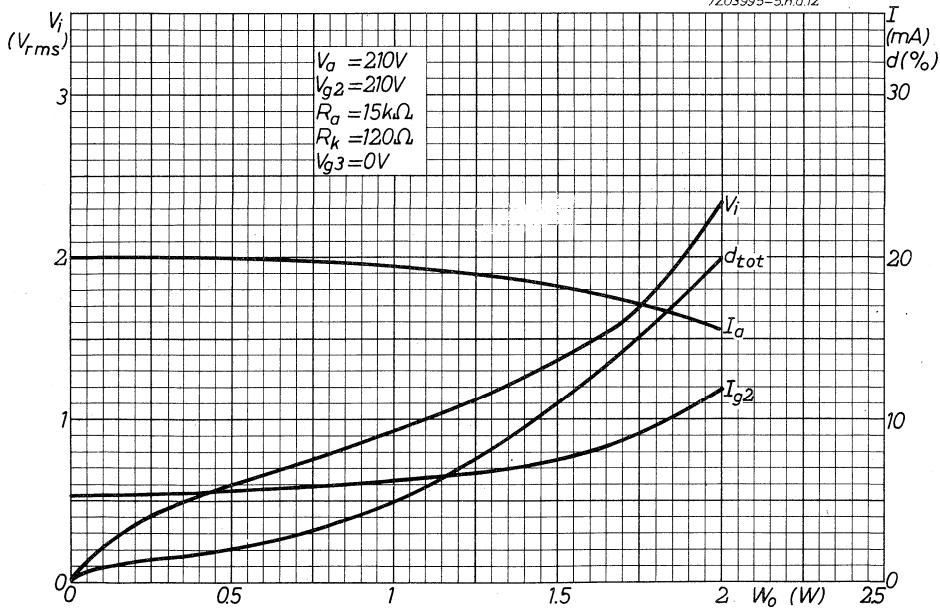

**S.Q. TUBE**

Special quality double triode designed for use as amplifier oscillator, multi-  
brator and blocking oscillator.



QUICK REFERENCE DATA	
Life	10 000 hours
Low interface resistance	
Mechanical quality	Shock and vibration resistant
Base	Noval
Heating	Indirect A.C. or D.C.; Parallel supply
Heater voltage	$V_f$ 6.3 or 12.6 V
Heater current	$I_f$ 300 or 150 mA
Anode current	$I_a$ 10.5 mA
Mutual conductance	$S$ 2.2 mA/V

**DIMENSIONS AND CONNECTIONS**

Dimensions in mm

Base: Noval

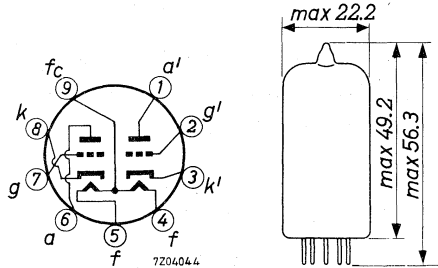

**CHARACTERISTICS** (Both sections if applicable)

Column I Nominal value or setting of the tube

II Range values for equipment design: Initial spread

III Range values for equipment design: End of life

		I	II	III	
Heater voltage, pin 9 and 4 + 5	$V_f$	6.3			V
Heater current	$I_f$	300	285- 315		mA
Heater voltage, pin 4 and 5	$V_f$	12.6			V
Heater current	$I_f$	150			mA
Anode voltage	$V_a$	250			V
Cathode resistor	$R_k$	800			$\Omega$
Anode current	$I_a$	10.5	8.7-12.3	min. 7.0	mA
Difference in anode current of both systems	$I_a - I_a'$		max. 1.6		mA
Mutual conductance	S	2.2	1.8- 2.6	min. 1.5	mA/V
Amplification factor	$\mu$	17.0	15.7-18.3		
Internal resistance	$R_i$	7.7			k $\Omega$
<u>Cut-off voltage</u>					
Grid voltage	$-V_g$	22			V
Anode current	$I_a$	10			$\mu A$
Grid voltage	$-V_g$		max. 30		V
Anode current	$I_a$	20			$\mu A$
Grid voltage	$-V_g$		min. 18		V
Anode current	$I_a$	5			$\mu A$
<u>Negative grid current</u>	$-I_g$		max. 0.5	max. 1.0	$\mu A$
Anode voltage	$V_a$	100			V
Grid voltage	$V_g$	0			V
Anode current	$I_a$	11.8			mA
Mutual conductance	S	3.1			mA/V
Amplification factor	$\mu$	19.5			
Internal resistance	$R_i$	6.25			k $\Omega$



**CHARACTERISTICS** (continued)

		I	II	
<u>Leakage current between cathode and heater</u>	$I_{kf}$		max. 6.5	$\mu A$
<u>Insulation resistance:</u>				
Between grid and other electrodes Voltage between electrodes = 100 V	$R_{ins}$		min. 500	$M\Omega$
Between anode and other electrodes Voltage between electrodes = 300 V	$R_{ins}$		min. 500	$M\Omega$
<u>Vibrational noise output (20 to 5000 Hz)</u>	$V_o$		max. 100	mV <sub>RMS</sub>
Anode voltage $V_a = 250$ V				
Grid voltage $-V_g = 8.5$ V				
Anode resistor $R_a = 2$ k $\Omega$				
Vibration frequency = 40 Hz				
Acceleration = 10 g				
Units in parallel				
<b>CAPACITANCES</b>				
Anode to cathode and heater	$C_{a/kf}$	0.5	0.3 - 0.7	pF
	$C_{a'/k'f}$	0.4	0.2 - 0.6	pF
Grid to cathode and heater	$C_{g/kf}$	1.6	1.25 - 1.95	pF
Anode to grid	$C_{ag}$	1.5	1.2 - 1.8	pF

**SHOCK AND VIBRATION RESISTANCE**

The following test conditions are applied to assess the mechanical quality of the tube. These conditions are not intended to be used as normal operating conditions.

Shock

The tube is subjected 5 times in each of 4 positions to an acceleration of 500 g supplied by an NRL shock machine with the hammer lifted over an angle of 30°.

Vibration

The tube is subjected during 32 hours in each of 3 positions to a vibration frequency of 50 Hz with an acceleration of 2.5 g.

## LIFE

Production samples are tested to be within the end of life values (column III) during 10 000 hours.

## LIMITING VALUES (Absolute max. rating system)

Anode voltage	$V_{a0}$	max. 600 V
	$V_a$	max. 330 V
Anode dissipation	$W_a$	max. 3 W
Grid voltage	$-V_g$	max. 55 V
	$+V_g$	max. 0 V
Grid current	$I_g$	max. 5 mA
Grid resistor: fixed bias	$R_g$	max. 0.5 M $\Omega$
	$R_g$	max. 1.0 M $\Omega$
Cathode current	$I_k$	max. 22 mA
Voltage between cathode and heater	$V_{kf}$	max. 100 V
Bulb temperature	$t_{bulb}$	max. 165 °C

Heater voltage: The average heater voltage should be 6.3 V.

Variations of the heater voltage exceeding the range of 6.0 V to 6.6 V will shorten the tube life.

The tolerance of heater current (column II) should be taken into account.

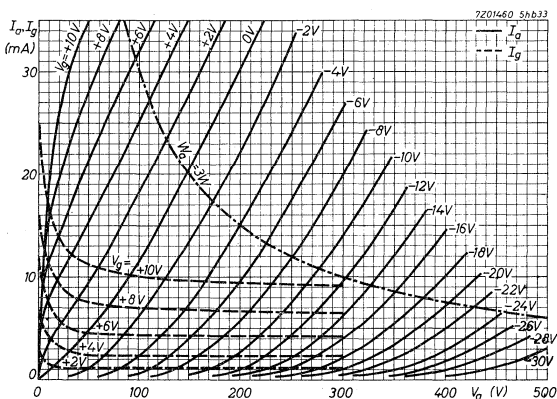

## S.Q. TUBE

Special quality double triode designed for use as A.F. amplifier, phase inverter and amplifier in measuring equipment.

### QUICK REFERENCE DATA

Life test	10 000 hours
Low interface resistance	
Low microphony level	
Mechanical quality	Shock and vibration resistant
Base	Noval
Heating	Indirect A.C. or D.C.; parallel supply
Heater voltage	$V_f$ 6.3 V or 12.6 V
Heater current	$I_f$ 300 mA or 150 mA
Anode current	$J_a$ 1.25 mA
Mutual conductance	S 1.6 mA/V
Amplification factor	$\mu$ 100

### DIMENSIONS AND CONNECTIONS

Dimensions in mm

Base: Noval

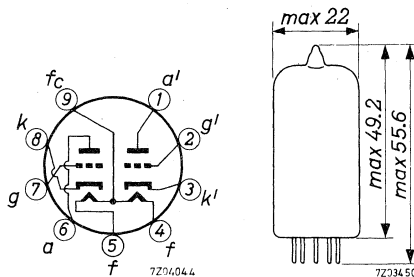

**CHARACTERISTICS** (Both systems if applicable)

Column I Nominal value or setting of the tube

II Range values for equipment design: Initial spread

III Range values for equipment design: End of life

		I	II	III	
Heater voltage pin 9 and 4 + 5	$V_f$	6.3			V
Heater current	$I_f$	300	285 - 315		mA
Heater voltage pin 4 and 5	$V_f$	12.6			V
Heater current	$I_f$	150			mA
Anode voltage	$V_a$	250			V
Cathode resistor	$R_k$	1.6			k $\Omega$
Anode current	$I_a$	1.25	1.1 - 1.4	min. 0.8	mA
Mutual conductance	S	1.6	1.3 - 1.95	min. 1.05	mA/V
Amplification factor	$\mu$	100			
Internal resistance	$R_i$	62.5			k $\Omega$
<u>Negative grid current</u>	$-I_g$		max. 0.2	max. 0.5	$\mu$ A
<u>Cut-off voltage</u>	$-V_g$		max. 4		V
Anode current $I_a = 20 \mu$ A					
Anode voltage	$V_a$	100			V
Anode current	$I_a$	0.5			mA
Cathode resistor	$R_k$	2			k $\Omega$
Mutual conductance	S	1.25			mA/V
Amplification factor	$\mu$	100			
Internal resistance	$R_i$	80			k $\Omega$
<u>Leakage current between cathode and heater</u>	$I_{kf}$		max. 5		$\mu$ A
Voltage between cathode and heater $V_{kf} = 100$ V					

**CHARACTERISTICS** (continued)Insulation resistance:

		I	II	
Between grid and other electrodes	$R_{ins}$		max. 300	$M\Omega$
Voltage between electrodes = 100 V				
Between anode and other electrodes	$R_{ins}$		max. 300	$M\Omega$
Voltage between electrodes = 300 V				

Vibrational noise output (20 to 5000 Hz)

	$V_o$		max. 10	mV <sub>RMS</sub>
Anode supply voltage $V_{ba} = 250$ V				
Anode resistor $R_a = 5$ k $\Omega$				
Grid voltage $-V_g = 2$ V				
Vibration frequency = 25 Hz				
Acceleration = 2.5 g				
Units in parallel				

**CAPACITANCES**

Grid to cathode and heater	$C_{g/kf}$	1.6		pF
Anode to cathode and heater	$C_{a/kf}$	0.46		pF
	$C_{a' /kf}$	0.34		pF
Anode to grid	$C_{ag}$	1.7		pF
Grid to heater	$C_{gf}$		max. 0.15	pF
Anode to anode other system	$C_{aa'}$		max. 0.6	pF
Grid to grid other system	$C_{gg'}$		max. 10	mpF
Anode to grid other system	$C_{ag'}$		max. 60	mpF
	$C_{ga'}$		max. 60	mpF

**LIMITING VALUES** (Absolute max. rating system) (Each unit)

Anode voltage	$V_{a0}$	max. 600	V
	$V_a$	max. 330	V
Anode dissipation	$W_a$	max. 1.2	W
Grid voltage	$-V_g$	max. 55	V
	$+V_g$	max. 0.5	V
Cathode current	$I_k$	max. 9	mA

## LIMITING VALUES (continued)

Grid resistor: fixed bias	$R_g$	max. 1.2	$M\Omega$
automatic bias	$R_g$	max. 2.2	$M\Omega$
grid current bias	$R_g$	max. 25	$M\Omega$
Voltage between cathode and heater	$V_{kf}$	max. 200	V
Resistance in cathode heater circuit in case of phase inverter circuit	$R_{kf}$	max. 135	$k\Omega$
Bulb temperature	$t_{bulb}$	max. 170	$^{\circ}C$
Microphony:			
Input voltage required for 50 mW output	$V_i$	min. 0.5	mV

Heater voltage: The average heater voltage should be 6.3 V  
 Variations of the heater voltage exceeding the range of 6.0 V to 6.6 V will shorten the tube life.  
 The tolerance of the heater current (column II) should be taken into account.

## OPERATING CHARACTERISTICS

### A.F. amplifier - circuit fig.1

Anode supply voltage	$V_{ba}$	200	250	300	350	400	V
Anode resistor	$R_a$	47	47	47	47	47	$k\Omega$
Cathode resistor	$R_k$	1500	1200	1000	820	680	$\Omega$
Grid resistor next stage	$R_{g'}$	150	150	150	150	150	$k\Omega$
Anode current	$I_a$	0.86	1.18	1.55	1.98	2.45	mA
Output voltage (Grid current = 0.3 $\mu A$ )	$V_o$	18	23	26	33	37	$V_{RMS}$
Voltage gain	$V_o/V_i$	34.0	37.5	40.0	42.5	44.0	
Total distortion	$d_{tot}$	8.5	7.0	5.0	4.4	3.6	%

## OPERATING CHARACTERISTICS (continued)

## A.F. amplifier - circuit fig.1 (continued)

Anode supply voltage	$V_{ba}$	200	250	300	350	400	V
Anode resistor	$R_a$	100	100	100	100	100	$k\Omega$
Cathode resistor	$R_k$	1800	1500	1200	1000	820	$\Omega$
Grid resistor next stage	$R_{g'}$	330	330	330	330	330	$k\Omega$
Anode current	$I_a$	0.65	0.86	1.11	1.40	1.72	mA
Output voltage (Grid current = 0.3 $\mu$ A)	$V_o$	20	26	30	36	38	$V_{RMS}$
Voltage gain	$V_o/V_i$	50	54.5	57.0	61.0	63.0	
Total distortion	$d_{tot}$	4.8	3.9	3.7	2.2	1.7	%
Anode supply voltage	$V_{ba}$	200	250	300	350	400	V
Anode resistor	$R_a$	220	220	220	220	220	$k\Omega$
Cathode resistor	$R_k$	3300	2700	2200	1500	1200	$\Omega$
Grid resistor next stage	$R_{g'}$	680	680	680	680	680	$k\Omega$
Anode current	$I_a$	0.36	0.48	0.63	0.85	1.02	mA
Output voltage (Grid current = 0.3 $\mu$ A)	$V_o$	24	28	36	37	38	$V_{RMS}$
Voltage gain	$V_o/V_i$	56	66.5	72.0	75.5	76.5	
Total distortion	$d_{tot}$	4.6	3.4	2.6	1.6	1.1	%

## A.F. amplifier - circuit fig.2.

Anode supply voltage	$V_{ba}$	200	250	300	350	400	V
Anode resistor	$R_a$	47	47	47	47	47	$k\Omega$
Grid resistor next stage	$R_{g'}$	150	150	150	150	150	$k\Omega$
Anode current	$I_a$	1.02	1.45	2.02	2.50	3.10	mA
Output voltage	$V_o$	18	23	26	33	37	$V_{RMS}$
Voltage gain	$V_o/V_i$	37	39	41	44	45	
Total distortion	$d_{tot}$	5.6	4.2	2.9	2.7	2.5	%



## OPERATING CHARACTERISTICS (continued)

### A.F. amplifier - circuit fig.2. (continued)

Anode supply voltage	$V_{ba}$	200	250	300	350	400	V
Anode resistor	$R_a$	100	100	100	100	100	k $\Omega$
Grid resistor next stage	$R_{g'}$	330	330	330	330	330	k $\Omega$
Anode current	$I_a$	0.70	1.00	1.29	1.62	1.95	mA
Output voltage	$V_o$	20	26	30	36	38	V <sub>RMS</sub>
Voltage gain	$V_o/V_i$	50	51	54	56	58	
Total distortion	$d_{tot}$	3.9	2.6	2.0	1.8	1.6	%

Anode voltage	$V_{ba}$	200	250	300	350	400	V
Anode resistor	$R_a$	220	220	220	220	220	k $\Omega$
Grid resistor next stage	$R_{g'}$	680	680	680	680	680	k $\Omega$
Anode current	$I_a$	0.39	0.56	0.75	0.88	1.09	mA
Output voltage	$V_o$	24	28	36	37	38	V
Voltage gain	$V_o/V_i$	58	62	66	67	68	
Total distortion	$d_{tot}$	4.6	2.7	2.2	1.7	1.4	%

### A.F. amplifier - circuit fig.3.

Anode supply voltage	$V_{ba}$	100	150	200	250	300	350	400	V
Anode resistor	$R_a$	47	47	47	47	47	47	47	k $\Omega$
Grid resistor next stage	$R_{g'}$	150	150	150	150	150	150	150	k $\Omega$
Anode current	$I_a$	0.35	0.84	1.40	1.95	2.52	3.19	3.80	mA
Voltage gain	$V_o/V_i$	25	33	34	36	38	40	41	

Total distortion:

at $V_o = 2 V_{RMS}$	$d_{tot}$	1.7	2.5	2.4	2.3	2.2	2.2	2.1	%
at $V_o = 4 V_{RMS}$	$d_{tot}$	2.1	4.6	4.7	4.6	4.5	4.2	4.2	%
at $V_o = 6 V_{RMS}$	$d_{tot}$	6.0	5.2	5.6	5.6	5.5	5.5	5.4	%



## OPERATING CHARACTERISTICS (continued)

## A.F. amplifier - circuit fig.3. (continued)

Anode supply voltage	$V_{ba}$	100	150	200	250	300	350	400	V
Anode resistor	$R_a$	100	100	100	100	100	100	100	k $\Omega$
Grid resistor next stage	$R_g$	330	330	330	330	330	330	330	k $\Omega$
Anode current	$I_a$	0.24	0.56	0.88	1.23	1.58	1.92	2.29	mA
Voltage gain	$V_o/V_i$	34	43	46	48	50	51	52	

## Total distortion:

at  $V_o = 2 V_{RMS}$   $d_{tot}$  1.6 1.9 1.9 1.8 1.8 1.8 1.7 %

at  $V_o = 4 V_{RMS}$   $d_{tot}$  2.3 3.0 3.8 3.8 3.6 3.6 3.5 %

at  $V_o = 6 V_{RMS}$   $d_{tot}$  2.6 4.7 5.1 5.1 5.0 4.9 4.8 %

Anode supply voltage	$V_{ba}$	100	150	200	250	300	350	400	V
Anode resistor	$R_a$	220	220	220	220	220	220	220	k $\Omega$
Grid resistor next stage	$R_g$	680	680	680	680	680	680	680	k $\Omega$
Anode current	$I_a$	0.14	0.32	0.49	0.67	0.85	1.05	1.23	mA
Voltage gain	$V_o/V_i$	42	51	54	57	58	59	60	

## Total distortion:

at  $V_o = 2 V_{RMS}$   $d_{tot}$  1.6 1.7 1.7 1.6 1.6 1.6 1.6 %

at  $V_o = 4 V_{RMS}$   $d_{tot}$  2.5 3.0 3.0 2.9 2.9 2.8 2.7 %

at  $V_o = 6 V_{RMS}$   $d_{tot}$  3.2 4.4 4.4 4.4 4.4 4.3 4.2 %

## Phase inverter - circuit fig.4

Supply voltage	$V_b$	250	350	V		
Anode voltage	$V_a$	65	90	V		
Anode resistor	$R_a, R_a'$	100	150	k $\Omega$		
Cathode resistor	$R_k$	68	82	k $\Omega$		
Anode current	$I_a + I_a'$	1.0	1.2	mA		
Voltage gain	$V_o/V_i$	25	27			
Output voltage	$V_o$	7	20	10	35	$V_{RMS}$
(Grid current = 0.3 $\mu A$ )						
Total distortion	$d_{tot}$	0.6	1.8	0.5	1.8	%

$V_a$  should be adjusted to the specified value for  $I_a + I_a'$

## OPERATING CHARACTERISTICS (continued)

Phase inverter - circuit fig.5.

Supply voltage	$V_b$	250	350	V
Cathode resistor	$R_k$	1200	820	$\Omega$
Anode current	$I_a + I_a'$	1.08	1.7	mA
Voltage gain	$V_o/V_i$	58		
Output voltage	$V_o$	7	35	V <sub>RMS</sub>
(Grid current = 0.3 $\mu$ A)		9	45	
Total distortion	$d_{tot}$	1.1	5.5	0.7 3.5 %

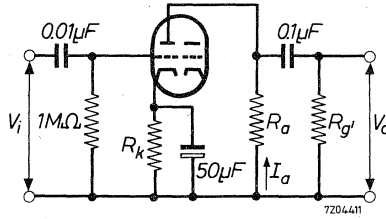

Fig. 1

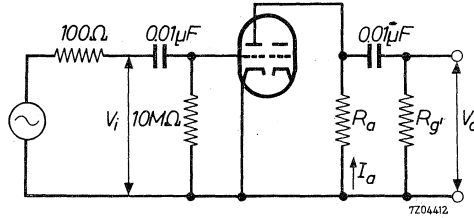

Fig. 2

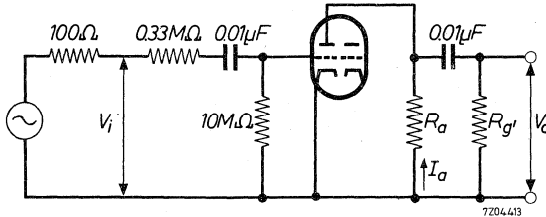

Fig. 3

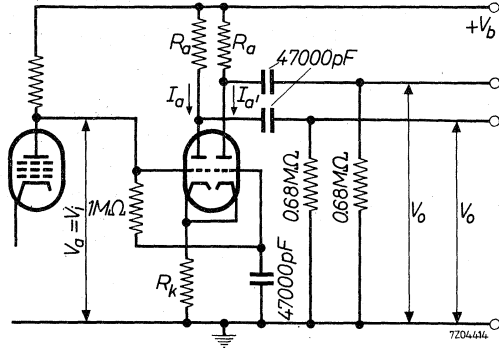

Fig. 4

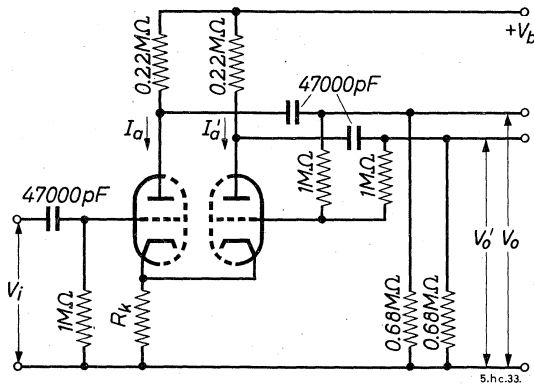
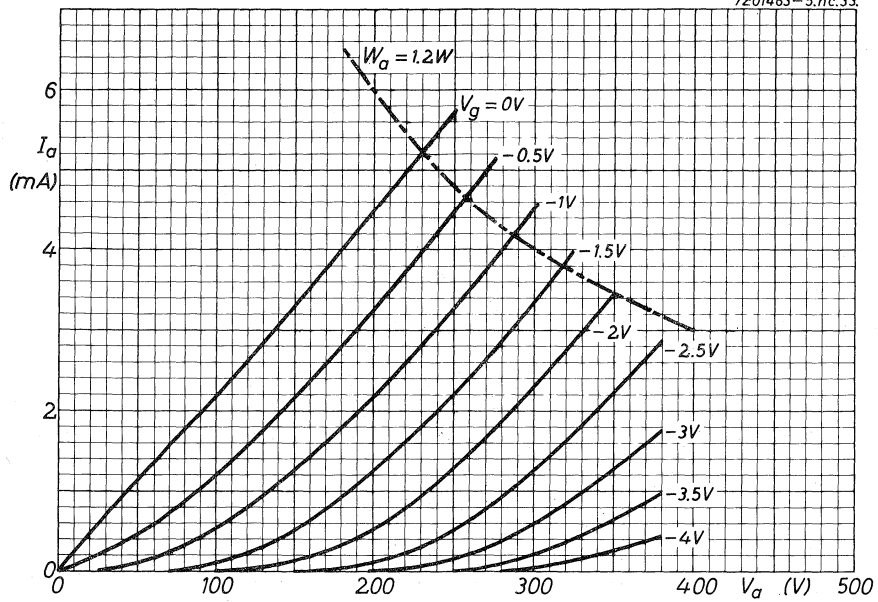

Fig. 5



## S.Q. TUBE

Special quality pentode designed for use in telephone equipment.

### QUICK REFERENCE DATA

Life expectancy	10 000 hours	
Low interface resistance		
Base	Noval. Gold plated pins	
Heating	Indirect A.C. or D.C. Series or parallel supply	
Heater voltage	$V_f$	6.3 V
Heater current	$I_f$	0.3 A
Anode current	$I_a$	10 mA
Mutual conductance	S	9 mA/V

### DIMENSIONS AND CONNECTIONS

Dimensions in mm

Base: Noval

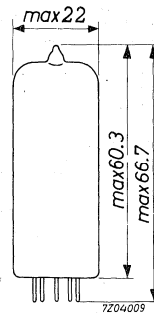
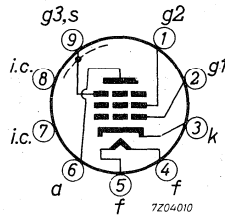

**CHARACTERISTICS**

Column I Nominal value or setting of the tube.

II Range values for equipment design: Initial spread

III Range values for equipment design: End of life

		I	II	III	
Heater voltage	$V_f$	6.3			V
Heater current	$I_f$	300	285 - 315		mA
Anode voltage	$V_a$	210			V
Grid No.3 voltage	$V_{g_3}$	0			V
Grid No.2 voltage	$V_{g_2}$	120			V
Cathode resistor	$R_k$	165			$\Omega$
Anode current	$I_a$	10	8.7 - 11.3	7	mA
Grid No.2 current	$I_{g_2}$	2.1	1.7 - 2.5	1.25	mA
Mutual conductance	S	9	7.8 - 10.2	6.4	mA/V
Internal resistance	$R_i$	0.5	min. 0.3		$M\Omega$
Amplification factor grid No.2 to grid No.1	$\mu_{g_2g_1}$	38			
Equivalent noise resistance (R.F.)	$R_{eq}$	750	max. 1000		$\Omega$
Equivalent noise resistance (A.F.)	$R_{eq}$		max. 36		k $\Omega$
<u>Negative grid No.1 current</u>	$-I_{g_1}$		max. 0.5	max. 1.0	$\mu A$
<u>Hum voltage</u>	$V_{g_1}$		max. 0.5		mVRMS
Grid resistor $R_{g_1} = 0.5 M\Omega$					
Cathode resistor by passed					
<u>Cut off voltage</u>	$-V_{g_1}$	5	max. 5.25		V
Anode voltage	$V_a$	210			V
Grid No.3 voltage	$V_{g_3}$	0			V
Grid No.2 voltage	$V_{g_2}$	120			V
Anode current	$I_a$	0.5			mA

**CHARACTERISTICS** (continued)

	I	II	III	
<u>Leakage current between cathode and heater</u>	$I_{kf}$	max. 15		$\mu A$
Voltage between heater and cathode $V_{kf} = 100 V$				
<u>Insulation resistance between two arbitrary electrodes</u>	R	min. 100		$M\Omega$
Voltage between electrodes $V = 250 V$				

**CAPACITANCES**

Radiation capacitances measured to a surrounding cylinder, internal diameter 52 mm, height 98 mm.

	I	II	
Grid No.1 to grid No.2, grid No.3, cathode, heater and screen	$C_{g_1/g_2g_3kfs}$	8	8.7 pF
Grid No.1 to grid No.2, grid No.3, cathode, heater and screen Cathode current = 12.1 mA	$C_{g_1/g_2g_3kfs}$	10.8	pF
Anode to grid No.2, grid No.3, cathode, heater and screen	$C_{a/g_2g_3kfs}$	3.5	max. 4.1 pF
Anode to grid No.1	$C_{ag_1}$		max. 15 mpF
Grid No.1 to heater	$C_{g_1f}$		max. 0.15 pF
Cathode to heater	$C_{kf}$	4	pF
Grid No.1 radiation capacitance	$C_{rg_1}$	max. 25	mpF
Anode radiation capacitance	$C_{ra}$	max. 25	mpF

**LIFE EXPECTANCY**

When the tube is operated under the following conditions the range values of the characteristics in column III may be expected not to be exceeded during an operation period of 10 000 hours.

Anode voltage	$V_a$	210 V
Grid No.3 voltage	$V_{g_3}$	0 V
Grid No.2 voltage	$V_{g_2}$	120 V
Cathode resistor	$R_k$	165 $\Omega$

## LIMITING VALUES (Design centre rating system)

Anode voltage	$V_{a0}$	max.	550	V
	$V_a$	max.	210	V
Anode dissipation	$W_a$	max.	2.1	W
Grid No.2 voltage	$V_{g20}$	max.	550	V
	$V_{g2}$	max.	210	V
Grid No.2 dissipation	$W_{g2}$	max.	0.35	W
Grid No.1 voltage	$-V_{g1}$	max.	100	V
Grid No.1 voltage, peak	$-V_{g1p}$	max.	200	V
Duty factor max. 0.1				
Pulse duration max. 200 $\mu$ s				
Grid No.1 dissipation	$W_{g1}$	max.	50	mW
Grid No.1 resistor (automatic bias)	$R_{g1}$	max.	1	M $\Omega$
Cathode current	$I_k$	max.	16	mA
Cathode current peak value	$I_{kp}$	max.	80	mA
Duty factor max. 0.1				
Pulse duration max. 200 $\mu$ s				
Voltage between heater and cathode	$V_{kf}$	max.	100	V
Bulb temperature (absolute maximum)	$t_{bulb}$	max.	170	$^{\circ}$ C

## OPERATING CHARACTERISTICS

### Output tube. Class A

Anode voltage	$V_a$	120	210	V
Grid No.3 voltage	$V_{g3}$	0	0	V
Grid No.2 supply voltage	$V_{bg2}$	120	120	V
Grid No.2 resistor	$R_{g2}$	5.6	5.6	k $\Omega$
Cathode resistor	$R_k$	180	180	$\Omega$
Anode current	$I_a$	8.3	8.3	mA
Grid No.2 current	$I_{g2}$	1.7	1.7	mA
Mutual conductance	$S$	8.2	8.2	mA/V
Internal resistance	$R_i$	0.42	0.44	M $\Omega$
Load resistance	$R_{a\sim}$	10	20	k $\Omega$
Input voltage	$V_i$	0.35	1.1	-
			0.25	1.1
				-
				$V_{RMS}$
Grid No.1 current	$+I_{g1}$	-	-	0.3
				-
				0.3
Grid No.1 resistor	$R_{g1}$	-	-	0.33
				M $\Omega$
Total distortion	$d_{tot}$	-	10	-
				10
				-
				%
Output power	$W_o$	50	340	400
			50	660
				870
				mW



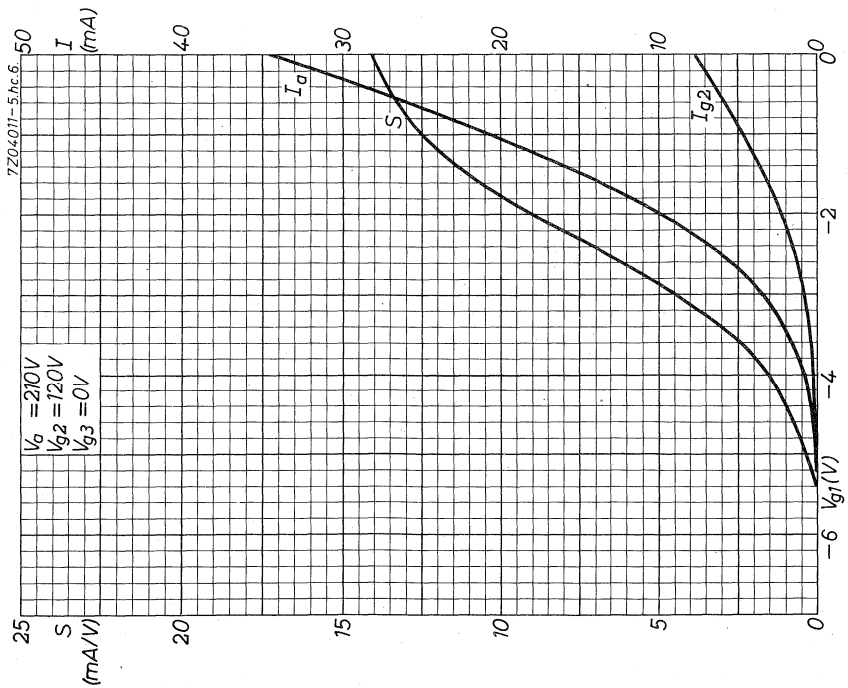
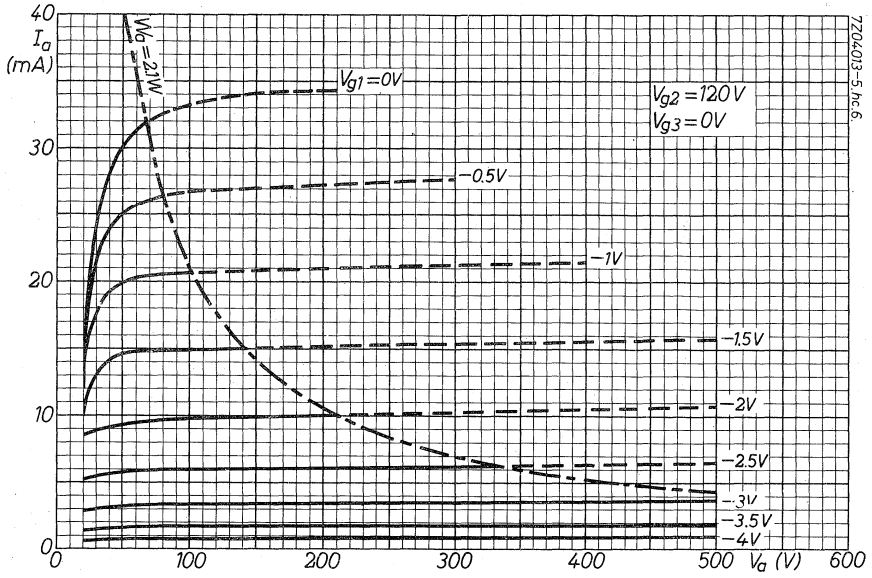

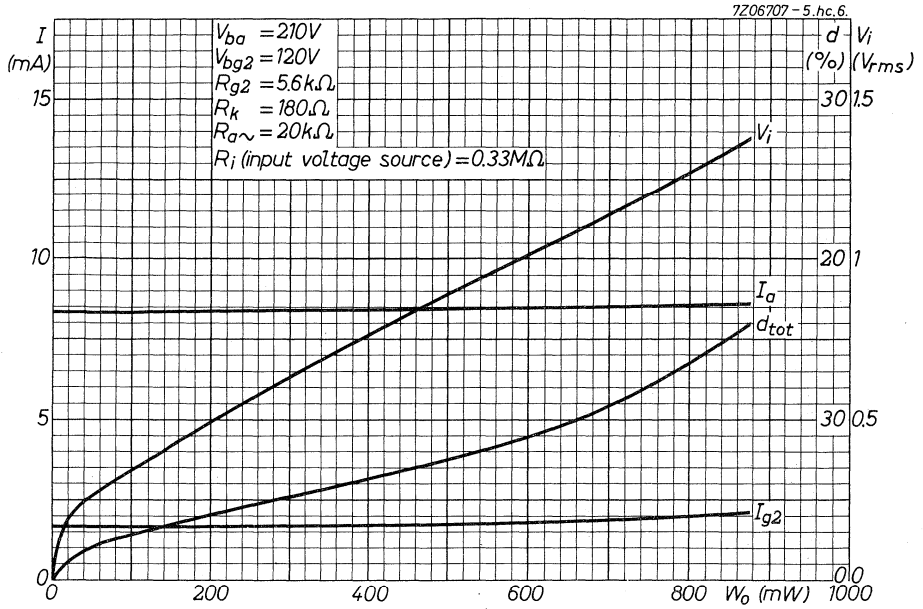

## S.Q. TUBE

Special quality output pentode designed for use as wide band amplifier, series regulator tube and power output tube.

### QUICK REFERENCE DATA

Life test	10 000 hours	
Low interface resistance		
Mechanical quality	Shock and vibration resistant	
Base	Noval	
Heating	Indirect	
	A. C. or D. C.; parallel supply	
Heater voltage	$V_f$	6.3 V
Heater current	$I_f$	760 mA
Anode current	$I_a$	48 mA
Mutual conductance	S	11.3 mA/V
Output power, one tube	$W_o$	6 W

### DIMENSIONS AND CONNECTIONS

Dimensions in mm

Base: Noval

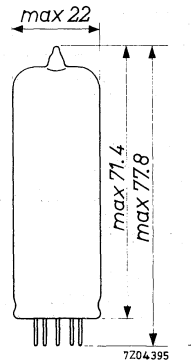
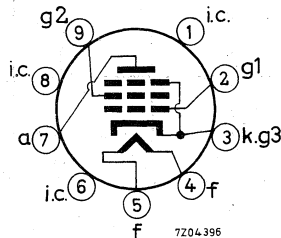

## CHARACTERISTICS

- Column I Nominal values or setting of the tube  
 II Range values for equipment design: Initial spread  
 III Range values for equipment design: End of life

		I	II	III	
Heater voltage	$V_f$	6.3			V
Heater current	$I_f$	760	720 - 800		mA
Anode voltage	$V_a$	250			V
Grid No. 2 voltage	$V_{g_2}$	250			V
Cathode resistor	$R_k$	135			$\Omega$
Anode current	$I_a$	48	42 - 54	min. 32	mA
Grid No. 2 current	$I_{g_2}$	5.5	4 - 7		mA
Mutual conductance	S	11.3	9.2 - 13.4	min. 7.5	mA/V
Amplification factor	$\mu_{g_2g_1}$	19			
Internal resistance	$R_i$	40			k $\Omega$
Negative grid current	$-I_{g_1}$		max. 0.5	max. 1.0	$\mu$ A
<u>As triode</u>					
Anode voltage	$V_a$	250			V
Cathode resistor	$R_k$	270			$\Omega$
Anode current	$I_a$	34			mA
Mutual conductance	S	10.2			mA/V
Amplification factor	$\mu$	18.5			
Internal resistance	$R_i$	1.8			k $\Omega$
<u>Leakage current between cathode and heater</u>	$I_{kf}$		max. 12.5		$\mu$ A
Voltage between cathode and heater $V_{kf} = 100$ V					
<u>Insulation resistance between electrodes</u>	R		min. 100		M $\Omega$
Voltage between electrodes = 300 V					

**CAPACITANCES**

		I	II	
Anode to grid No. 2, grid No. 3 cathode and heater	$C_{a/g_2g_3kf}$	6.0	5.2 - 6.8	pF
Grid No. 1 to grid No. 2, grid No. 3 cathode and heater	$C_{g_1/g_2g_3kf}$	10	9 - 11	pF
Anode to grid No. 1	$C_{ag_1}$		max. 0.5	pF
Grid No. 1 to heater	$C_{g_1f}$		max. 0.25	pF

**SHOCK AND VIBRATION RESISTANCE**

The following test conditions are applied to assess the mechanical quality of the tube. These conditions are not intended to be used as normal operating conditions.

Shock

The tube is subjected 5 times in each of 4 positions to an acceleration of 500 g supplied by an NRL shock machine with the hammer lifted over an angle of 30°.

Vibration

The tube is subjected during 32 hours in each of 3 positions to a vibration frequency of 50 Hz with an acceleration of 2.5 g.

**LIFE**

Production samples are tested to be within the end of life values (column III) during 10 000 hours

**LIMITING VALUES** (Absolute max. rating system)

Anode voltage	$V_{a_0}$	max.	600 V
	$V_a$	max.	450 V
Anode dissipation	$W_a$	max.	13.5 W
Grid No. 2 voltage	$V_{g_{20}}$	max.	600 V
	$V_{g_2}$	max.	450 V
Grid No. 2 dissipation	$W_{g_2}$	max.	2.2 W
		max.	4.4 W
Continuously			
Peak value in case of excitation by speech and music	$W_{g_{2p}}$	max.	4.4 W

## LIMITING VALUES (continued)

Grid No. 1 dissipation	$W_{g1}$	max.	0.5	W
Grid No. 1 voltage	$-V_{g1}$	max.	100	V
Cathode current	$I_k$	max.	75	mA
Grid resistor				
Fixed bias	$R_{g1}$	max.	0.5	MΩ
Automatic bias	$R_{g1}$	max.	1.0	MΩ
Voltage between cathode and heater	$V_{kf}$	max.	100	V
Bulb temperature	$t_{bulb}$	max.	225	°C

Heater voltage: The average heater voltage should be 6.3 V.

Variations of the heater voltage exceeding the range of 6.0 V to 6.6 V will shorten the tube life.

The tolerance of heater current (column II) should be taken into account.

## OPERATING CHARACTERISTICS

Output tube class A (one tube) 2)3)

Anode voltage	$V_a$	250	V
Grid No. 2 voltage	$V_{g2}$	250	V
Cathode resistor	$R_k$	135	Ω
Load resistance	$R_{a\sim}$	4.5	kΩ
-----			
Input voltage	$V_i$	0 0.3 3.5 4.4	$4.8^1) V_{RMS}$
Anode current	$I_a$	48	50.5 50.5 mA
Grid No. 2 current	$I_{g2}$	5.5	10.0 11.0 mA
Output power	$W_o$	0 0.05 4.5 5.7	6.0 W
Total distortion	$d_{tot}$		7.5 10 %
Second harmonic	$d_2$		5.7 5.0 %
Third harmonic	$d_3$		4.5 8.0 %

## OPERATING CHARACTERISTICS (continued)

## Output tube class A (one tube) 2)3)

Anode voltage	$V_a$			250		V
Grid No.2 voltage	$V_{g_2}$			250		V
Cathode resistance	$R_k$			135		$\Omega$
Load resistance	$R_{a\sim}$			5.2		$k\Omega$
Input voltage	$V_i$	0	0.3	3.4	4.3	4.7 <sup>1)</sup> $V_{RMS}$
Anode current	$I_a$	48			49.5	49.2 mA
Grid No.2 current	$I_{g_2}$	5.5			10.8	11.6 mA
Output power	$W_o$	0	0.05	4.5	5.7	6.0 W
Total distortion	$d_{tot}$			6.8	10	%
Second harmonic	$d_2$			3.0	2.0	%
Third harmonic	$d_3$			5.8	9.5	%
Anode voltage	$V_a$			250		V
Grid No.2 voltage	$V_{g_2}$			250		V
Cathode resistance	$R_k$			210		$\Omega$
Load resistance	$R_{a\sim}$			7.0		$k\Omega$
Input voltage	$V_i$	0	0.3		3.5	5.5 <sup>1)</sup> $V_{RMS}$
Anode current	$I_a$	36			36.8	36 mA
Grid No.2 current	$I_{g_2}$	4.1			8.5	14.6 mA
Output power	$W_o$	0	0.05		4.2	5.6 W
Total distortion	$d_{tot}$				10	%
Second harmonic	$d_2$				1.7	%
Third harmonic	$d_3$				8.7	%

## OPERATING CHARACTERISTICS (continued)

### Output tube class A (one tube) <sup>2)</sup>

Anode voltage	$V_a$	250	V
Grid No. 2 voltage	$V_{g2}$	210	V
Cathode resistor	$R_k$	160	$\Omega$
Load resistance	$R_{a\sim}$	7.0	$k\Omega$

Input voltage	$V_i$	0	0.3	3.4	3.8 <sup>1)</sup>	$V_{RMS}$
Anode current	$I_a$	36		36.6	36.5	mA
Grid No. 2 current	$I_{g2}$	3.9		7.3	8.0	mA
Output power	$W_o$	0	0.05	4.3	4.7	W
Total distortion	$d_{tot}$			10		%
Second harmonic	$d_2$			1.8		%
Third harmonic	$d_3$			9.3		%

### Output tube class AB (two tubes) <sup>2)</sup>

Anode voltage	$V_a$	250		300	V	
Grid No. 2 voltage	$V_{g2}$	250		300	V	
Cathode resistor	$R_k$	130		130	$\Omega$	
Load resistance	$R_{aa\sim}$		8		8	$k\Omega$
Input voltage	$V_i$	0	8	0	10 <sup>3)</sup>	$V_{RMS}$
Anode current	$I_a$	2x31	2x37.5	2x36	2x46	mA
Grid No. 2 current	$I_{g2}$	2x3.5	2x7.5	2x4	2x11	mA
Output power	$W_o$	0	11	0	17	W
Total distortion	$d_{tot}$		3		4	%



## OPERATING CHARACTERISTICS (continued)

Output tube class B (two tubes)

Anode voltage	$V_a$	250	300	V		
Grid No.2 voltage	$V_{g2}$	250	300	V		
Grid No.1 voltage	$-V_{g1}$	11.6	14.7	V		
Load resistance	$R_{aa \sim}$	8	8	k $\Omega$		
Input voltage	$V_i$	0	8	10 <sup>3</sup> ) $V_{RMS}$		
Anode current	$I_a$	2x10	2x37.5	2x7.5	2x46	mA
Grid No.2 current	$I_{g2}$	2x1.1	2x7.5	2x0.8	2x11	mA
Output power	$W_o$	0	11	0	17	W
Total distortion	$d_{tot}$		3		4	%

As triodeOutput tube class A (one tube)

Anode voltage	$V_a$	250	V		
Cathode resistor	$R_k$	270	$\Omega$		
Load resistance	$R_{a \sim}$	3.5	k $\Omega$		
Input voltage	$V_i$	0	1.0	6.7	$V_{RMS}$
Anode current	$I_a$	34	36	mA	
Output power	$W_o$	0	0.05	1.95	W
Total distortion	$d_{tot}$			9.0	%

Output tube class AB (2 tubes)

Anode voltage	$V_a$	250	300	V				
Cathode resistor	$R_k$	270	270	$\Omega$				
Load resistance	$R_{aa \sim}$	10	10	k $\Omega$				
Input voltage	$V_i$	0	0.95	8.3	0	0.9	10	$V_{RMS}$
Anode current	$I_a$	2x20	2x21.7	2x24	2x26	mA		
Output power	$W_o$	0	0.05	3.4	0	0.05	5.2	W
Total distortion	$d_{tot}$			2.5			2.5	%

1) Grid No.1 current  $I_{g1} = 0.3 \mu A$ 

2) Measured with fixed bias

3) With speech and music signal

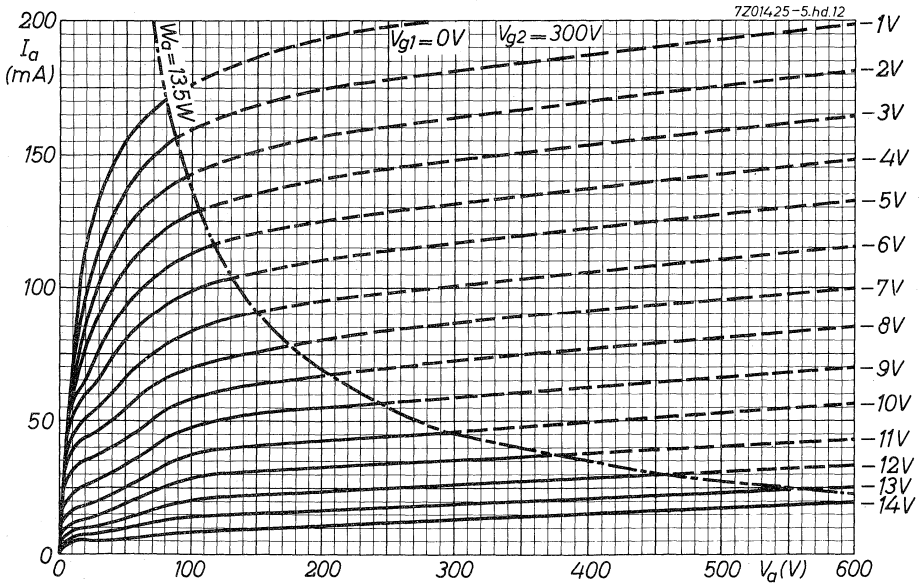
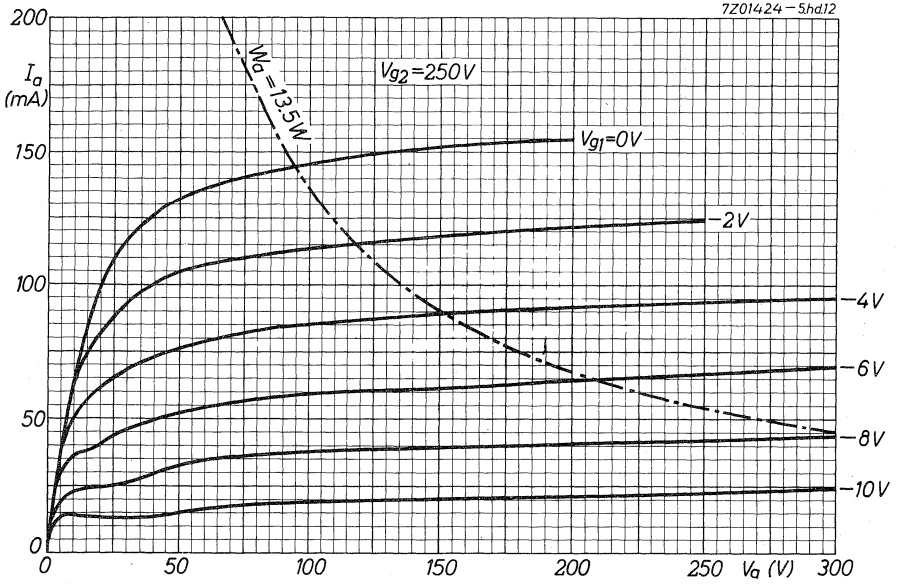

## S.Q. TUBE

Special quality U.H.F. triode designed for use as oscillator, amplifier and self-oscillating mixer (max. frequency 800 MHz).

### QUICK REFERENCE DATA

Life	10 000 hours	
Low interface resistance		
Mechanical quality	Shock and vibration resistant	
Base	Noval. Gold plated pins.	
Heating	Indirect A.C. or D.C.; Parallel supply	
Heater voltage	$V_f$	6.3 V
Heater current	$I_f$	165 mA
Anode current	$I_a$	12 mA
Mutual conductance	S	14 mA/V

### DIMENSIONS AND CONNECTIONS

Dimensions in mm

Base: Noval

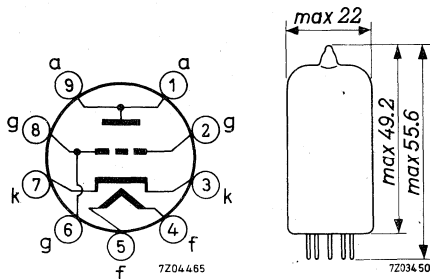

## CHARACTERISTICS

Column I Nominal value or setting of the tube

II Range values for equipment design: Initial spread

III Range values for equipment design: End of life

		I	II	III	
Heater voltage	$V_f$	6.3			V
Heater current	$I_f$	165	155 - 175		mA
Anode supply voltage	$V_{ba}$	185			V
Grid supply voltage	$+V_{bg}$	8			V
Cathode resistor	$R_k$	800			$\Omega$
Anode current	$I_a$	12	11.2 - 12.8	min. 10.5	mA
Mutual conductance	S	14	11.5 - 17	min. 9.5	mA/V
Amplification factor	$\mu$	68			
<u>Negative grid current</u>	$-I_g$		max. 0.5	max. 1.0	$\mu$ A
<u>Cut-off voltage</u>	$-V_g$		max. 5		V
Anode current $I_a = 0.1$ mA					
<u>Equivalent noise resistance</u>	$R_{eq}$	250			$\Omega$
<u>Input resistance</u>	$r_g$	2			k $\Omega$
Frequency = 100 MHz					
<u>Phase angle of slope</u>	$\varphi_s$	-7			o
Frequency = 100 MHz					
<u>Leakage current between cathode and heater</u>	$I_{kf}$		max. 10		$\mu$ A
Voltage between cathode and heater $V_{kf} = 100$ V					
<u>Insulation resistance between anode and other electrodes</u>	$R_{ins}$		min. 100		M $\Omega$
Voltage between anode and other electrode = 300 V					
<u>Insulation resistance between grid and other electrode</u>	$R_{ins}$		min. 100		M $\Omega$
Voltage between grid and other electrode = 100 V					

**CAPACITANCES**

		I	II	
Anode to grid	$C_{ag}$	2	1.7 - 2.3	pF
Anode to cathode	$C_{ak}$	0.2	0.16 - 0.24	pF
Grid to cathode	$C_{gk}$	3.6	3.0 - 4.2	pF
Grid to heater	$C_{gf}$		max. 0.3	pF
Cathode to grid and heater	$C_{k/gf}$	6.6	5.5 - 7.7	pF
Anode to grid and heater	$C_{a/gf}$	2.1	1.75 - 2.45	pF
Grid to cathode and heater	$C_{g/kf}$	3.9	3.3 - 4.5	pF
Anode to cathode and heater	$C_{a/kf}$	0.3	0.25 - 0.35	pF
Grid to cathode	$C_{gk}$	5.6		pF
Anode current $I_a = 12$ mA				
<u>With external shield</u>				
Anode to grid and shield	$C_{a/gs}$	3.1	2.8 - 3.4	pF
Grid and shield to cathode and heater	$C_{gs/kf}$	4.2	3.6 - 4.8	pF
Anode to cathode and heater	$C_{a/kf}$	0.25	0.2 - 0.3	pF

**SHOCK AND VIBRATION RESISTANCE**

The following test conditions are applied to assess the mechanical quality of the tube. These conditions are not intended to be used as normal operating conditions.

Shock

The tube is subjected 5 times in each of 4 positions to an acceleration of 500 g supplied by an NRL shock machine with the hammer lifted over an angle of 30°.

Vibration

The tube is subjected during 32 hours in each of 3 positions to a vibration frequency of 50 Hz with an acceleration of 2.5 g.

**LIFE**

Production samples are tested to be within the end of life values (column III) during 10 000 hours.

Heater voltage: The average heater voltage should be 6.3 V. Variations of the heater voltage exceeding the range of 6.0 V to 6.6 V will shorten the tube life. The tolerance of heater current (column II) should be taken into account.

## LIMITING VALUES (Absolute max. rating system)

Anode voltage	$V_{a_0}$	max. 440	V
	$V_a$	max. 250	V
Anode dissipation	$W_a$	max. 2.4	W
Grid voltage	$-V_g$	max. 50	V
Grid dissipation	$W_g$	max. 20	mW
Grid resistor	$R_g$	max. 1.2	M $\Omega$
Cathode current	$I_k$	max. 20	mA
Voltage between cathode and heater	$V_{kf}$	max. 100	V
Bulb temperature	$t_{bulb}$	max. 165	$^{\circ}C$
Frequency (as amplifier)	f	up to 800	MHz

## OPERATING CHARACTERISTICS

### As R.F. amplifier, grounded grid

Anode supply voltage	$V_{ba}$	185	175	V
Grid supply voltage	$V_{bg}$	8	0	V
Cathode resistor	$R_k$	800	125	$\Omega$
Anode current	$I_a$	12	12	mA
Mutual conductance	S	14	14	mA/V

### As mixer

Anode supply voltage	$V_{ba}$	220	V
Anode resistor	$R_a$	5.6	k $\Omega$
Grid resistor	$R_g$	47	k $\Omega$
Anode current	$I_a$	12	mA
Grid current	$I_g$	50	$\mu A$

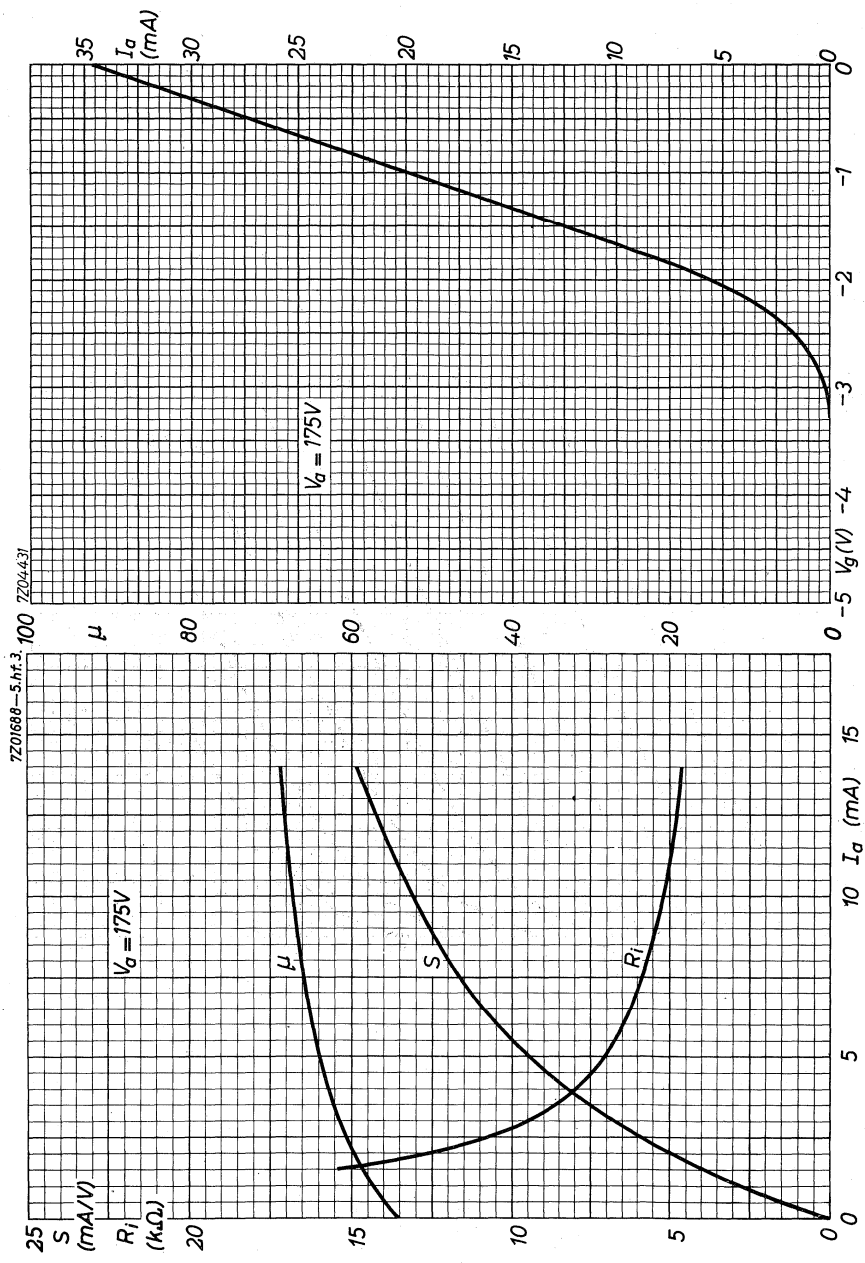

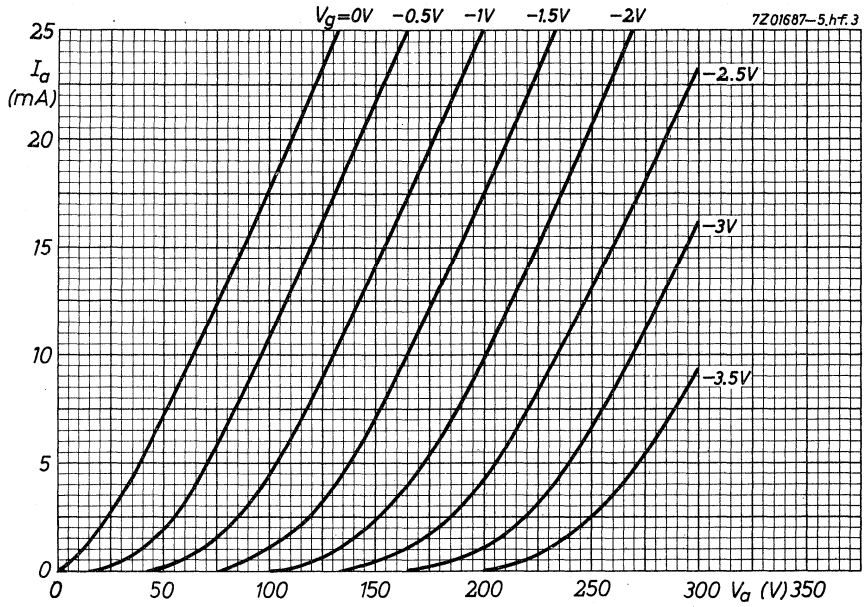



## S.Q. TUBE

Special quality triode. Designed for use as grounded grid aerial amplifier for band IV and V.

QUICK REFERENCE DATA	
Life test	10 000 hours
Low interface resistance	
Mechanical quality	Shock and vibration resistant
Base	Noval. Gold plated pins
Heating	Indirect A.C. or D.C.; parallel supply
Heater voltage	$V_f$ 6.3 V
Heater current	$I_f$ 165 mA
Anode current	$I_a$ 12.5 mA
Mutual conductance	$S$ 13.5 mA/V
Noise figure at 850 MHz	$F$ 9.6 dB
Equivalent noise resistance	$R_{eq}$ 240 $\Omega$

### DIMENSIONS AND CONNECTIONS

Dimensions in mm

Base: Noval

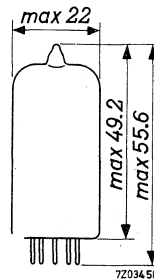
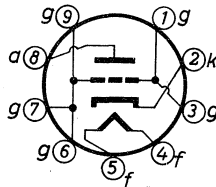

## CHARACTERISTICS

Column I Nominal value

II Range values for equipment design: Initial spread

		I	II	
Heater voltage	$V_f$	6.3		V
Heater current	$I_f$	165	157-173	mA
Anode voltage	$V_a$	160		V
Grid voltage	$-V_g$	1.25		V
Anode current	$I_a$	12.5		mA
Mutual conductance	S	13.5		mA/V
Amplification factor	$\mu$	70		
Internal resistance	$R_i$	5.2		k $\Omega$
Equivalent noise resistance	$R_{eq}$	240		$\Omega$
Noise figure	F	9.6		dB
Frequency 850 MHz				
Bandwidth 15 MHz				
Anode supply voltage	$V_{ba}$	170		V
Cathode resistor	$R_k$	820		$\Omega$
Grid supply voltage	$+V_{bg}$	9		V
Anode current	$I_a$	12.5		mA
Mutual conductance	S	13.5	10.5-16.5	mA/V
Anode supply voltage	$V_{ba}$	161		V
Cathode resistor	$R_k$	100		$\Omega$
Grid supply voltage	$V_{bg}$	0		V
Anode current	$I_a$	12.5	9.5-16.1	mA
Mutual conductance	S	13.5		mA/V
Grid current, negative	$-I_g$		max. 0.1	$\mu$ A
<u>Leakage current between cathode and heater</u>	$I_{kf}$		max. 15	$\mu$ A
Voltage between cathode and heater $V_{kf} = 125$ V				

**CHARACTERISTICS** (continued)

		I	
Input series resonance frequency <sup>1)</sup>	$f_{inp}$	1700	MHz
Output series resonance frequency <sup>1)</sup>	$f_{outp}$	1000	MHz

**CAPACITANCES**

		With screen		Without screen		
		I	II	I	II	
Anode to cathode and heater	$C_{a/kf}$	50	35- 65			mpF
Grid to cathode and heater	$C_{g/kf}$	3.8	3.2-4.4			pF
Anode to grid	$C_{ag}$	1.7	1.4-2.0	1.1	0.9 - 1.3	pF

**SHOCK AND VIBRATION RESISTANCE**

The following test conditions are applied to assess the mechanical quality of the tube. These conditions are not intended to be used as normal operating conditions.

Shock

The tube is subjected 5 times in each of 4 positions to an acceleration of 500 g supplied by an NRL shock machine with the hammer lifted over an angle of 30°.

Vibration

The tube is subjected during 32 hours in each of 3 positions to a vibration frequency of 50 Hz with an acceleration of 2.5 g.

**LIFE**

Production samples are tested during 10 000 hours under the following conditions:

Anode supply voltage	$V_{ba}$	170	V
Grid supply voltage	$+V_{bg}$	9	V
Cathode resistor	$R_k$	820	$\Omega$

<sup>1)</sup> Measured between the tube pin connected to the relevant electrode and a metal reference plane placed against the tube bottom. The relevant pin and the reference plane are connected to the measuring device so that the minimum distance is obtained between these two connecting points. The remaining tube pins are connected to the reference plane with a negligible impedance. The tube is screened by a cylinder with an internal diameter of 23 mm placed on the reference plane.

**LIMITING VALUES** (Absolute max. rating system)

Anode voltage	$V_{a0}$	max.	400 V
	$V_a$	max.	200 V
Anode dissipation	$W_a$	max.	2.6 W
Cathode current	$I_k$	max.	16.5 mA
Grid voltage	$-V_g$	max.	50 V
Grid dissipation	$W_g$	max.	50 mW
Grid resistor	$R_g$	max.	1 M $\Omega$
Cathode resistor $R_k = 100 \Omega$			
Voltage between cathode and heater			
Cathode positive	$V_{kf(k+)}$	max.	125 V
Cathode negative	$V_{kf(k-)}$	max.	60 V
Bulb temperature	$t_{bulb}$	max.	170 °C

Heater voltage: The average heater voltage should be 6.3 V.

Variation of the heater voltage exceeding the range of 6.0 V to 6.6 V will shorten the tube life.

**OPERATING CHARACTERISTICS**Driver or output tube (circuit fig. 1)

Frequency	$f$	800	MHz
Bandwidth		8	MHz
Anode supply voltage	$V_{ba}$	200	V
Anode resistor	$R_a$	1.5	k $\Omega$
Cathode resistor	$R_k$	150	$\Omega$
Input voltage	$V_i$	0 0.5 1.65	$V_{RMS}$
Anode current	$I_a$	11.4 12.8	mA
Output voltage	$V_o$	0 2.0 6.0	$V_{RMS}^1)$
Inter modulation ratio		min. 26	dB
Sync. impuls compression		max. 30	%

<sup>1)</sup> Value of the sync. level with video modulation according to CCIR and with  $Z = 60 \Omega$ .

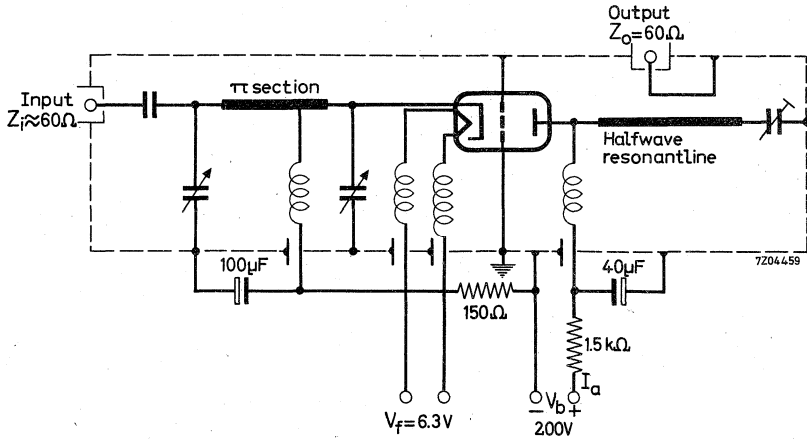
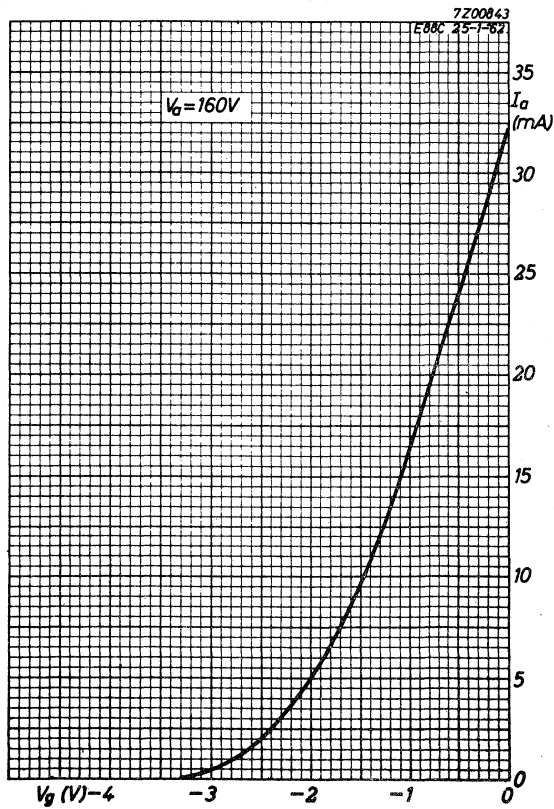
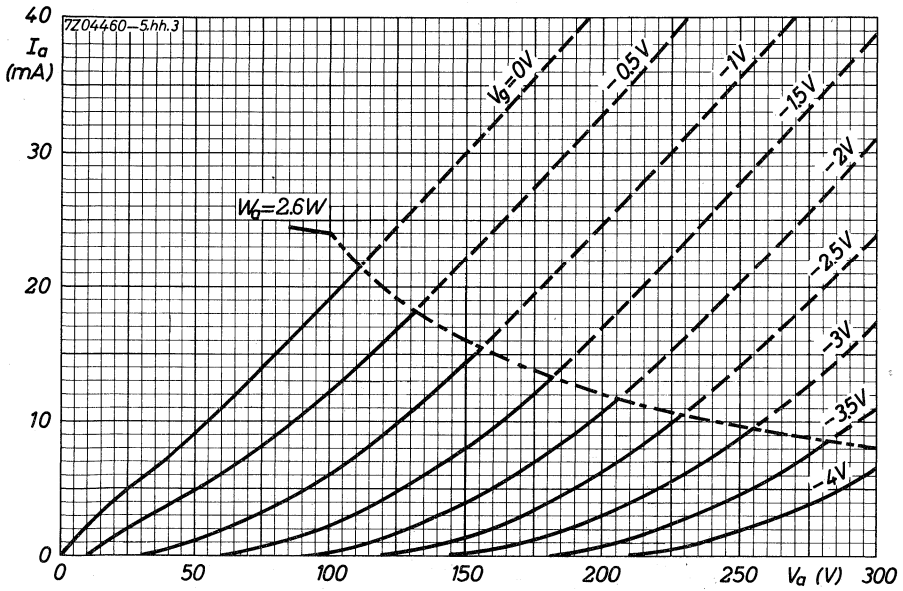

Fig.1





## S.Q. TUBE

Special quality double triode designed for  
 Cascode circuits  
 H.F. or I.F. amplifiers  
 Mixer or phase inverter stages  
 Multivibrator and cathode follower in computers

### QUICK REFERENCE DATA

Life	10 000 hours	
Low interface resistance		
Mechanical quality	Shock and vibration resistant	
Base	Noval. Gold plated pins	
Heating	Indirect A.C. or D.C.; parallel supply	
Heater voltage	$V_f$	6.3 V
Heater current	$I_f$	300 mA
Anode current	$I_a$	15 mA
Mutual conductance	$S$	12.5 mA/V
Equivalent noise resistance	$R_{eq}$	300 $\Omega$
Noise factor ( $f = 200$ MHz)	$F$	4.6 dB

### DIMENSIONS AND CONNECTIONS

Dimensions in mm

Base: Noval

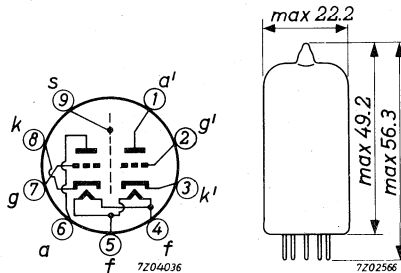

## CHARACTERISTICS

Column I Nominal value or setting of the tube

II Range values for equipment design: Initial spread

III Range values for equipment design: End of life

		I	II	III	
Heater voltage	$V_f$	6.3			V
Heater current	$I_f$	300	285 - 315		mA
Anode supply voltage	$V_{ba}$	100			V
Grid supply voltage	$+V_{bg}$	9			V
Cathode resistor	$R_k$	680			$\Omega$
Anode current	$I_a$	15	14.2 - 15.8	min. 13.5	mA
Mutual conductance	S	12.5	10.5 - 15	min. 9	mA/V
Amplification factor	$\mu$	33			
<u>Equivalent noise resistance</u>	$R_{eq}$	300			$\Omega$
Frequency = 45 MHz					
<u>Noise figure</u>	F	4.6			dB
Frequency = 200 MHz					
In cascode circuit adapted to minimum noise					
<u>Input resistance</u>	$r_g$	3			k $\Omega$
Frequency = 100 MHz					
<u>Start of grid current</u>	$V_g$	0.75			$V_{RMS}$
<u>Negative grid current</u>	$-I_g$		max. 0.1	max. 1	$\mu A$
Anode voltage	$V_a$	90			V
Anode current	$I_a$	15			mA
Anode supply voltage	$V_{ba}$	90			V
Cathode resistor	$R_k$	120			$\Omega$
Anode current	$I_a$	12			mA
Mutual conductance	S	11.5			mA/V



## CHARACTERISTICS (continued)

		I	II	III	
<u>Cut-off voltage</u>	$-V_g$	6.5	5 - 8.5		V
Anode voltage	$V_a$	150			V
Anode current	$I_a$	0.1			mA
<hr/>					
<u>Difference in grid voltage</u> of two sections	$ V_g - V_g' $		max. 2	max. 2	V
Anode voltage	$V_a = V_a'$	150			V
Anode current	$I_a = I_a'$	0.1			mA
Anode supply voltage	$V_{ba}$	150			V
Negative grid voltage	$-V_g$	15			V
Anode current	$I_a$		max. 5		$\mu A$
<hr/>					
<u>In circuit fig. 1 "pag. 7"</u>					
Anode supply voltage	$V_{ba}$	150			V
Anode current (not permitted continuously)	$I_a$	33	28 - 38		mA
Anode supply voltage	$V_{ba}$	60			V
Anode current	$I_a$		max. 9		mA
<hr/>					
<u>Leakage current between cathode and heater</u>	$I_{kf}$		max. 6	max. 12	$\mu A$
Voltage between cathode and heater = 90 V, cath. neg.					
Voltage between cathode and heater = 120 V, cath. pos.					
<hr/>					
<u>Insulation resistance between two electrodes</u>	$R_{ins}$		min. 100	min. 20	$M\Omega$
Voltage between electrodes = 200 V					
<hr/>					
<u>Hum voltage</u>	$V_g$		max. 50		$\mu V_{RMS}$
Centre heater transformer earthed					
Grid resistor $R_g = 0.5 M\Omega$					

**CAPACITANCES** Both sections if applicable

		I	II	
Anode to cathode, heater and screen	$C_a/kfs$	1.75	1.55 - 1.95	pF
	$C_a'/k'fs$	1.65	1.45 - 1.85	pF
Anode to cathode and heater	$C_a/kf$	0.5	0.4 - 0.6	pF
	$C_a'/k'f$	0.4	0.3 - 0.5	pF
Grid to cathode, heater and screen	$C_g/kfs$	3.3	2.7 - 3.9	pF
Grid to cathode and heater	$C_g/kf$	3.3	2.7 - 3.9	pF
Anode to grid	$C_{ag}$	1.4	1.2 - 1.6	pF
Anode to cathode	$C_{ak}$	0.18	0.14 - 0.22	pF
Cathode to heater	$C_{kf}$	2.6		pF
	$C_k'f$	2.7		pF
Anode to screen	$C_{as}$	1.3	1.1 - 1.5	pF
Anode to grid, heater and screen	$C_a/gfs$	3.0	2.7 - 3.3	pF
	$C_a'/g'fs$	2.9	2.6 - 3.2	pF
Cathode to grid, heater and screen	$C_k/gfs$	6.0	5.1 - 6.9	pF
Anode to anode other section	$C_{aa'}$		max. 0.045	pF
Grid to grid other section	$C_{gg'}$		max. 0.005	pF
Anode to grid other section	$C_{ag'}, C_a'g$		max. 0.005	pF
Grid to cathode other section	$C_{gk'}, C_g'k$		max. 0.005	pF

**SHOCK AND VIBRATION RESISTANCE**

The following test conditions are applied to assess the mechanical quality of the tube. These conditions are not intended to be used as normal operating conditions.

Shock

The tube is subjected 5 times in each of 4 positions to an acceleration of 500 g supplied by an NRL shock machine with the hammer lifted over an angle of 30°.

Vibration

The tube is subjected during 32 hours in each of 3 positions to a vibration frequency of 50 Hz with an acceleration of 2.5 g.

**LIFE**

Production samples are tested to be within the end of life values (column III) during 10 000 hours under the following conditions:

Anode supply voltage	$V_{ba}$	100 V
Grid supply voltage	$+V_{bg}$	9 V
Cathode resistor	$R_k$	680 $\Omega$
Grid resistor	$R_g$	47 k $\Omega$
Voltage between cathode and heater (cath.neg.)	$V_{kf}$	60 V
Anode current	$I_a$	15 mA

**LIMITING VALUES** Design centre rating system

Anode voltage	$V_{a0}$	max.	550 V
Anode voltage (Zero cathode current)	$V_a$	max.	400 V
Anode voltage	$V_a$	max.	220 V
Anode voltage (Max. anode dissipation 0.8 W)	$V_a$	max.	250 V
Anode dissipation	$W_a$	max.	1.5 W
Anode dissipation (Max. anode dissipation of section 1 plus section 2 = 2 W)	$W_a$	max.	1.8 W
Grid dissipation	$W_g$	max.	30 mW
Grid voltage	$-V_g$	max.	100 V
Grid peak voltage Max. pulse duration 200 $\mu$ sec Max. duty factor 0.1	$-V_{gp}$	max.	200 V
Cathode current	$I_k$	max.	20 mA
Cathode peak current Max. pulse duration 200 $\mu$ sec Max. duty factor 0.1	$I_{kp}$	max.	100 mA

## LIMITING VALUES (continued)

Voltage between cathode and heater

Cathode positive	$V_{kf}$	max.	150 V
Cathode negative	$V_{kf}$	max.	100 V
Bulb temperature (Absolute max.)	$t_{bulb}$	max.	170 °C
Grid resistor (Anode current < 5 mA)	$R_g$	max.	1 MΩ

Heater voltage: The average heater voltage should be 6.3 V.

Variations of the heater voltage exceeding the range of 6.0 V to 6.6 V will shorten the tube life.

The tolerance of heater current (column II) should be taken into account.

## OPERATING CHARACTERISTICS

### Output tube class A

Anode voltage	$V_a$	220	V
Load resistance	$R_{a\sim}$	20	kΩ
Grid voltage	$-V_g$	6.5	V
Input voltage	$V_i$	0 1.5 4.5	V <sub>RMS</sub>
Anode current	$I_a$	6.5	9.2 mA
Output power	$W_o$	0.05 0.5	W
Total distortion	$d_{tot}$		7 %

### Output tube class B (two tubes)

Continuous single tone input signal

Anode voltage	$V_a$	200	V
Load resistance	$R_{aa\sim}$	22	kΩ
Grid voltage	$-V_g$	6	V
Input voltage	$V_i$	0 0.9 4.0	V <sub>RMS</sub>
Anode current	$I_a$	2x5	2x9 mA
Output power	$W_o$	0.05 1.2	W
Total distortion	$d_{tot}$		3 %

**OPERATING CHARACTERISTICS (continued)**

Output tube class B (two tubes)

Speech and music input signal

Anode voltage	$V_a$	200	V	
Load resistance	$R_{a-a\sim}$	10	$k\Omega$	
Grid voltage	$-V_{g1}$	6		V
Input voltage	$V_i$	0	0.9	4.0 $V_{RMS}$
Anode current	$I_a$	2x5	2x13.5 mA	
Output power	$W_o$	0.05	1.5 W	
Total distortion	$d_{tot}$			4 %

Mixer

Anode supply voltage	$V_{ba}$	60	90	150 V
Anode resistor	$R_a$	0	1	3.9 $k\Omega$
Grid resistor	$R_g$	1	1	1 $M\Omega$
Oscillator voltage	$V_{osc}$	2	2.5	3 $V_{RMS}$
Anode current	$I_a$	4.7	7.7	11 mA
Conversion conductance	$S_c$	2.9	3.5	4.1 mA/V
Internal resistance	$R_i$	8.3	7	6.1 $k\Omega$

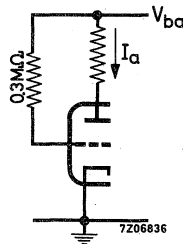
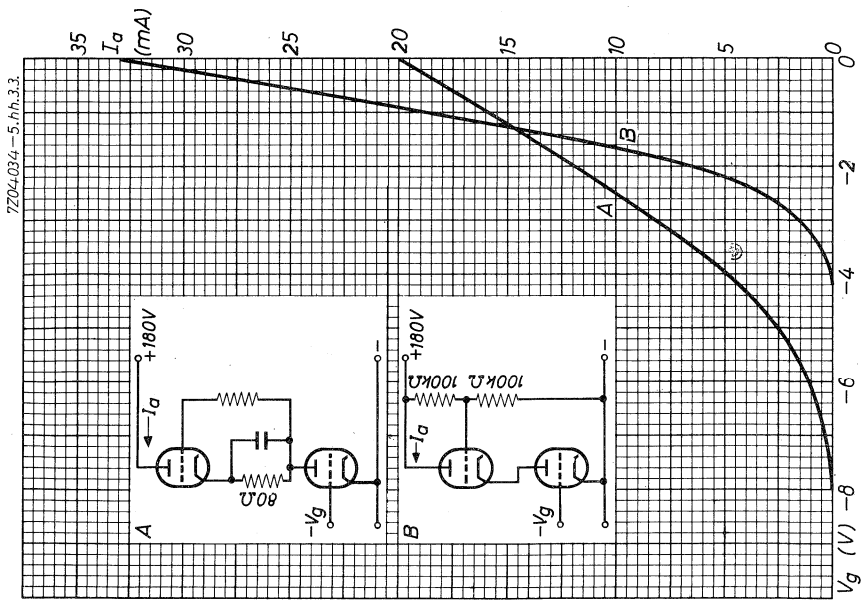
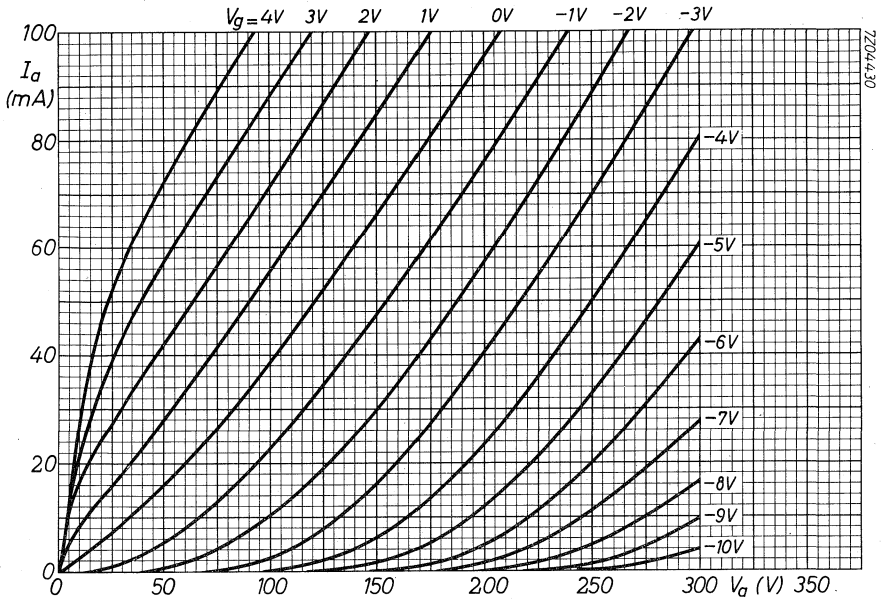

Fig. 1



7Z04-034-5, nh.3.3.

## S.Q. TUBE

Special quality double triode designed for use in computer circuits.

### QUICK REFERENCE DATA

Life expectancy	10 000 hours	
Low interface resistance		
Base	Miniature, 7 pin	
Heating	Direct A.C. or D.C. Series or parallel supply	
Heater voltage	$V_f$	6.3 V
Heater current	$I_f$	400 mA

### DIMENSIONS AND CONNECTIONS

Dimensions in mm

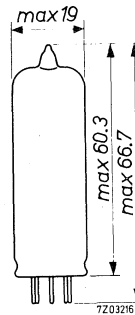
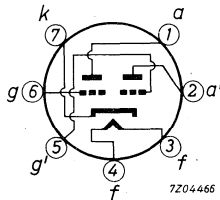

**CHARACTERISTICS**

- Column I Nominal value or setting of the tube
- II Range values for equipment design: Initial spread
- III Range values for equipment design: End of life

		I	II	III	
Heater voltage	$V_f$	6.3			V
Heater current	$I_f$	400	380 - 420		mA
Anode voltage	$V_a$	100			V
Negative grid voltage	$-V_g$	2.1			V
Anode current	$I_a$	8.5	4.5 - 12.5		mA
Mutual conductance	S	6.0			mA/V
Amplification factor	$\mu$	27			
Anode voltage	$V_a$	100			V
Cathode resistor	$R_k$	250			$\Omega$
Mutual conductance	S	6.0	4.5 - 7.5	min. 3.0	mA/V
<u>Negative grid current</u>	$-I_{g1}$		max. 0.2	max. 1.0	$\mu A$
Anode supply voltage	$V_{ba}$	150			V
Anode resistor	$R_a$	20			k $\Omega$
Grid resistor	$R_g$	47			k $\Omega$
Anode current	$I_a$	5.6	5.0 - 6.2	min. 4.5	mA
Grid supply voltage	$V_{bg}$	0			V
Anode current	$I_a$		max. 0.1	max. 0.1	mA
Grid supply voltage	$-V_{bg}$	10			V
Difference in grid voltage of two sections	$ V_g - V_g' $		max. 2	max. 2	V
Anode current	$I_a = I_a'$	0.1			V
<u>Leakage current between cathode and heater</u>	$I_{kf}$		max. 15	max. 30	$\mu A$
Voltage between cathode and heater	$V_{kf}$	100			V
<u>Insulation between two electrodes</u>	$R_{ins}$		min. 100	min. 20	M $\Omega$
Voltage between electrodes	V	300			V



**CAPACITANCES** Each system if applicable.

		I	II	
Anode to cathode and heater	$C_{a/kf}$	0.35	0.25 - 0.45	pF
	$C_{a'/k'f}$	0.4	0.3 - 0.5	pF
Grid to cathode and heater	$C_{g/kf}$	3.4	2.9 - 3.9	pF
Anode to grid	$C_{ag}$	2.5	2.0 - 3.0	pF
Grid to heater	$C_{gf}$		max. 0.15	pF
	$C_{g'f}$		max. 0.3	pF
Anode to anode other section	$C_{aa'}$		max. 1.4	pF
Grid to grid other section	$C_{gg'}$		max. 0.22	pF
Anode to grid other section	$C_{ag'}$		max. 0.35	pF
Grid to anode other section	$C_{ga'}$		max. 0.15	pF
Cathode to heater	$C_{kf}$	6.5		pF

**LIFE**

Production samples are tested to be within the end of life values (column III) under the following conditions during 10 000 hours:

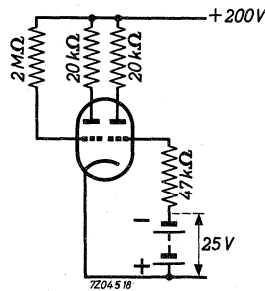

$I_a = 8 \text{ mA}$

$I_{a'} = 0 \text{ mA}$

$V_{kf} = 100 \text{ V (k pos)}$

## LIMITING VALUES (Absolute max. rating system)

Anode voltage	$V_{a0}$	max.	600 V
	$V_a$	max.	300 V
Anode dissipation	$W_a$	max.	2.0 W
Grid voltage	$+V_g$	max.	0 V
	$-V_g$	max.	100 V
Grid peak voltage	$-V_{gp}$	max.	200 V
Grid current	$I_g$	max.	250 $\mu$ A
Grid, peak current	$I_{gp}$	max.	1 mA
max. pulse duration 2.5 msec			
Cathode current	$I_k$	max.	15 mA
Cathode peak current	$I_{kp}$	max.	75 mA
max. pulse duration 2 msec			
Voltage between cathode and heater	$V_{kf}$	max.	100 V
Grid resistor, automatic bias	$R_g$	max.	1 $M\Omega$
fixed bias	$R_g$	max.	0.5 $M\Omega$
Bulb temperature	$t_{bulb}$	max.	170 $^{\circ}$ C

Heater voltage: The average heater should be 6.3 V.

Variations of the heater voltage exceeding the range of 6.0 V to 6.6 V will shorten the tube life.

The tolerance of heater current (column II) should be taken into account.

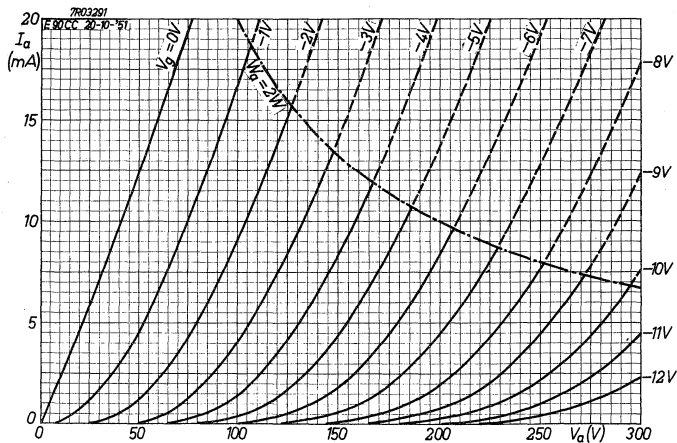

## S.Q. TUBE

Special quality tube designed for use as wide band amplifier, cathode follower, series regulator tube for stabilised d.c. supply and output tube.

### QUICK REFERENCE DATA

Life test	10 000 hours	
Mechanical quality	Shock and vibration resistant	
Base	Octal	
Heating	Indirect A.C. or D.C.; parallel supply	
Heater voltage	$V_f$	6.3 V
Heater current	$I_f$	1.7 A
Anode current	$I_a$	100 mA
Mutual conductance	S	27.5 mA/V
Output power, one tube	$W_o$	11.5 W
two tubes, class AB	$W_o$	60 W

### DIMENSIONS AND CONNECTIONS

Dimensions in mm

Base: Octal

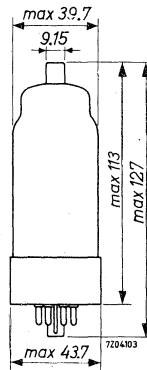
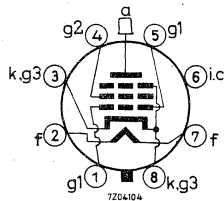

**CHARACTERISTICS**

Column I Nominal value or setting of the tube

II Range values for equipment design: Initial spread

III Range values for equipment design: End of life

		I	II	III	
Heater voltage	$V_f$	6.3			V
Heater current	$I_f$	1.7	1.62 - 1.78		A
Anode voltage	$V_a$	250			V
Grid No.2 voltage	$V_{g2}$	150			V
Grid No.1 voltage	$-V_{g1}$	15.5			V
Anode current	$I_a$	100			mA
Grid No.2 current	$I_{g2}$	4			mA
Mutual conductance	S	27.5			mA/V
Amplification factor	$\mu_{g2g1}$	6.5			
Internal resistance	$R_i$	10			k $\Omega$
Anode supply voltage	$V_{ba}$	275			V
Grid No.2 supply voltage	$V_{bg2}$	180			V
Positive grid No.1 supply voltage	$V_{bg1}$	15.7			V
Cathode resistor	$R_k$	300			$\Omega$
Anode current	$I_a$	100	85 - 115	decrease max.40%	mA
Grid No.2 current	$I_{g2}$	4	max. 6		mA
Mutual conductance	S	27.5	22.5 - 32.5	decrease max.30%	mA/V
Negative grid No.1 current	$-I_{g1}$		max. 0.5	max. 1	$\mu$ A
<u>Cut off voltage</u>					
Anode voltage	$V_a$	250			V
Grid No.2 voltage	$V_{g2}$	150			V
Anode current	$I_a$	1			mA
Negative grid No.1 voltage	$-V_{g1}$		max. 30		V

### CHARACTERISTICS (continued)

Insulation resistance  
between one electrode and all  
other electrodes measured  
with  $V = 400$  V

	II	III	
$R_{isol}$	min. 100	min. 20	$M\Omega$

### CAPACITANCES Without external shield

Grid No.1 to grid No.3, grid No.2,  
cathode and heater

	I	II	
$C_{g_1/g_3g_2kf}$	35		pF
Anode to grid No.3, grid No.2, cathode and heater	$C_a/g_3g_2kf$	17	pF
Anode to grid No.1	$C_{ag_1}$	max. 2	pF

### SHOCK AND VIBRATION RESISTANCE

The following test conditions are applied to assess the mechanical quality of the tube. These conditions are not intended to be used as normal operating conditions.

#### Shock

The tube is subjected 5 times in each of 4 positions to an acceleration of 500 g supplied by an NRL shock machine with the hammer lifted over an angle of  $30^\circ$ .

#### Vibration

The tube is subjected during 32 hours in each of 3 positions to a vibration frequency of 50 Hz with an acceleration of 2.5 g.

### LIFE

Production samples are tested to be within the end of life values (column III) under the following conditions during 10 000 hours.

Anode supply voltage	$V_{ba}$	275 V
Grid No.2 supply voltage	$V_{bg_2}$	180 V
Grid No.1 supply voltage	$+V_{bg_1}$	15.7 V
Cathode resistor	$R_k$	300 $\Omega$
Grid No.1 resistor	$R_{g_1}$	47 $k\Omega$
Voltage between cathode and heater cathode positive	$V_{kf}$ (k pos)	100 V

## LIMITING VALUES (Absolute max. rating system)

Anode voltage	$V_{a0}$	max. 2000 V
	$V_a$	max. 900 V
Anode and grid No.2 voltage (triode connection)	$V_{a+g2}$	max. 250 V
Anode peak voltage	$+V_{ap}$	max. 8000 V
Pulse duration: 18% of a cycle		
Anode peak voltage	$-V_{ap}$	max. 2000 V
Anode dissipation	$W_a$	max. 27.5 W
Anode plus grid No.2 dissipation (triode connection)	$W_{a+g2}$	max. 27.5 W
Grid No.2 voltage	$V_{g20}$	max. 550 V
	$V_{g2}$	max. 250 V
Grid No.2 dissipation	$W_{g2}$	max. 5 W
Grid No.1 voltage	$-V_{g1}$	max. 150 V
	$+V_{g1}$	max. 15 V
Grid No.1 dissipation	$W_{g1}$	max. 0.1 W
Grid No.1 resistor with fixed bias	$R_{g1}$	max. 0.5 MΩ
with automatic bias	$R_{g1}$	max. 1.0 MΩ
Cathode current	$I_k$	max. 300 mA
Cathode peak current	$I_{kp}$	max. 1.5 A
Pulse duration max. 4 ms		
Average value max. 150 mA		
Cathode peak current	$I_{kp}$	max. 4.6 A
Pulse duration max. 1.5 μs		
Average value max. 14 mA		
Voltage between cathode and heater		
Cathode positive	$V_{kf}$ (k pos)	max. 200 V
Cathode negative	$V_{kf}$ (k neg)	max. 100 V
Bulb temperature	$t_{bulb}$	max. 225 °C

**LIMITING VALUES** (continued)

Heater voltage: The average heater voltage should be 6.3 V.

Variations of the heater voltage exceeding the range of 6.0 V to 6.6 V will shorten the tube life. The tolerance of the heater current (column II) should be taken into account.

**OPERATING CHARACTERISTICS**Output tube class A

Anode voltage	$V_a$	250	V
Grid No.2 voltage	$V_{g_2}$	150	V
Grid No.1 voltage	$-V_{g_1}$	15.5	V
Load resistance	$R_{a\sim}$	2.7	$k\Omega$
Input voltage	$V_i$	3.82	$V_{RMS}$
Anode current	$I_a$	100	mA
Grid No.2 current	$I_{g_2}$	18	mA
Output power	$W_o$	11.5	W
Total distortion	$d_{tot}$	10	%

Output tube class AB (2 tubes)

Anode voltage	$V_a$	300	V
Grid No.2 voltage	$V_{g_2}$	150	V
Grid No.1 voltage	$-V_{g_1}$	17	V
Load resistance	$R_{aa\sim}$	1.6	$k\Omega$
Input voltage	$V_i$	0 0.24 9.0	$V_{RMS}$
Anode current	$I_a$	2x80 - 2x182	mA
Grid No.2 current	$I_{g_2}$	2x2.5 - 2x22	mA
Output power	$W_o$	0 0.05 60	W
Total distortion	$d_{tot}$	- - 5	%

7Z04105-5.acj12

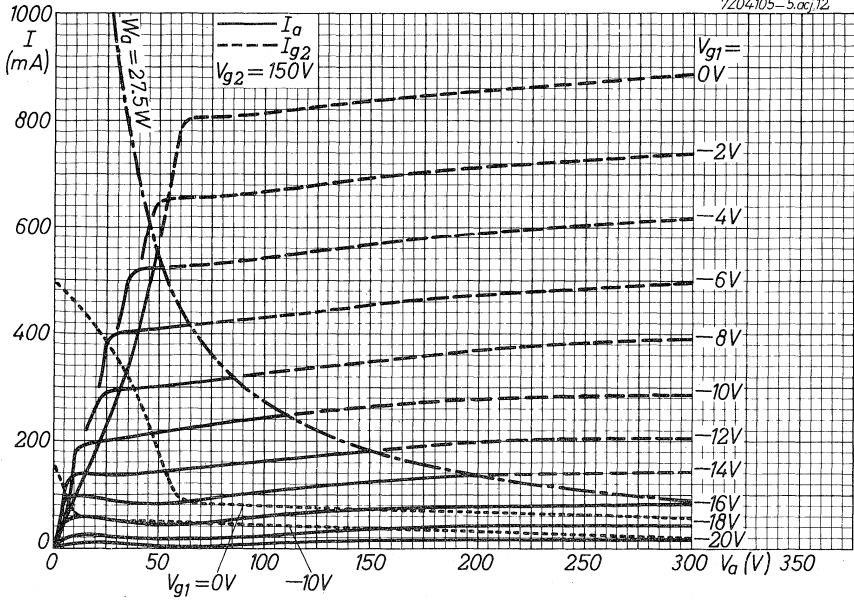

7Z04109-5.acj12

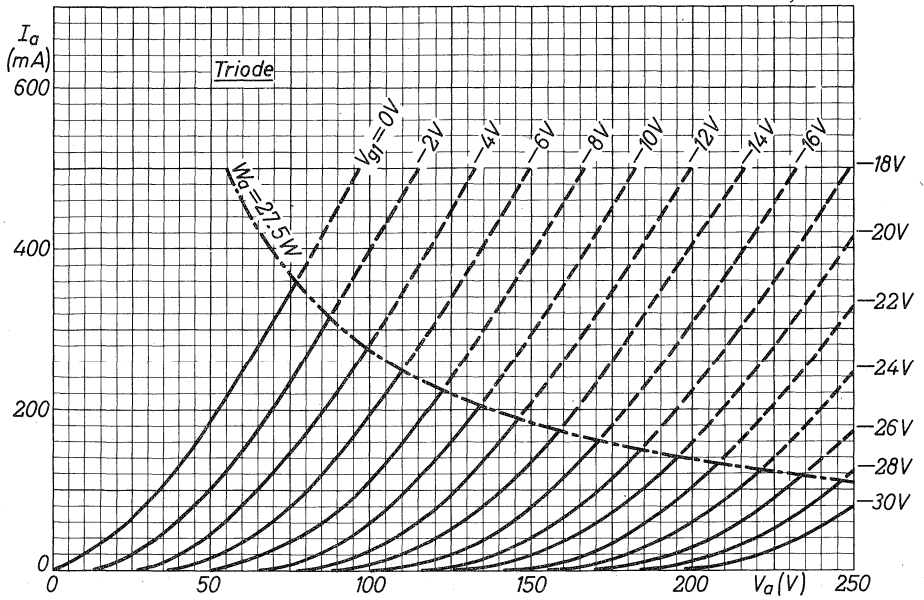



## S.Q. TUBE

Special quality double triode designed for use in computer circuits.

### QUICK REFERENCE DATA

Life test	10 000 hours	
Low interface resistance		
Base	Noval	
Heating	Indirect A.C. or D.C.; parallel supply	
Heater voltage	$V_f$	6.3 or 12.6 V
Heater current	$I_f$	400 or 200 mA

### DIMENSIONS AND CONNECTIONS

Dimensions in mm

Base: Noval

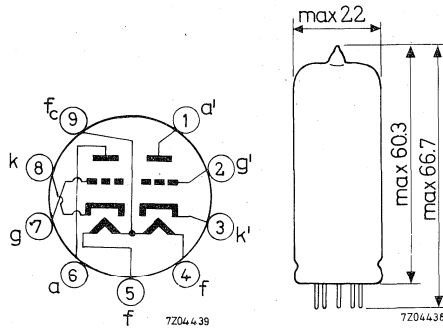

**CHARACTERISTICS**

Column I Nominal value or setting of the tube  
 II Range values for equipment design: Initial spread  
 III Range values for equipment design: End of life

		I	II	III	
Heater voltage (pin 9 and 4 and 5)	$V_f$	6.3			V
Heater current	$I_f$	400	380 - 420		mA
Heater voltage (pin 4 and 5)	$V_f$	12.6			V
Heater current	$I_f$	200			mA
Anode voltage	$V_a$	150			V
Grid voltage	$-V_g$	1.85			V
Anode current	$I_a$	8.5			mA
Mutual conductance	S	6.4			mA/V
Amplification factor	$\mu$	46			
Internal resistance	$R_i$	7.2			k $\Omega$
Anode voltage	$V_a$	150			V
Cathode resistor	$R_k$	220			$\Omega$
Anode current	$I_a$	8.5	6.3 - 10.7	min. 5.0	mA
Mutual conductance	S	6.4	5.3 - 8.1	min. 4.0	mA/V
Negative grid current	$-I_g$		max. 0.2	max. 1.0	$\mu$ A
<u>Cut off voltage</u>	$-V_g$	7.5			V
Anode voltage	$V_a$	150			V
Anode current	$I_a$		max. 150	max. 150	$\mu$ A
<u>Difference in grid voltage</u> of 2 sections	$ V_g - V_g' $		max. 2	max. 2	V
Anode voltage	$V_a$	150			V
Anode current	$I_a$	0.15			mA

CHARACTERISTICS (continued)

		I	II	III	
Anode voltage	$V_a$	100			V
Grid voltage	$-V_g$	0.8			V
Anode current	$I_a$	8.5			mA
Mutual conductance	S	7.8			mA/V
Amplification factor	$\mu$	50			
Internal resistance	$R_i$	6.4			k $\Omega$
Anode voltage	$V_a$	100			V
Grid supply voltage	$+V_{bg}$	100			V
Grid resistor	$R_g$	0.5			M $\Omega$
Anode current	$I_a$	17.8	13.6 - 22.0	min. 9.5	mA
<u>Leakage current between cathode and heater</u>	$I_{kf}$		max. 15	max. 30	$\mu$ A
Voltage between cathode and heater $V_{kf} = 200$ V					
Series resistor = 1 M $\Omega$					
<u>Insulation resistance between two electrodes</u>			min. 100	min. 20	M $\Omega$
Voltage between electrodes V = 275 V					

CAPACITANCES Without external screen

Each system if applicable

		I	II	
Anode to cathode and heater	$C_{a/kf}$	0.5	0.3 - 0.7	pF
Anode to cathode and heater	$C_{a'/k'f}$	0.45	0.25 - 0.65	pF
Grid to cathode and heater	$C_{g/kf}$	3.5	3.0 - 4.0	pF
Anode to grid	$C_{ag}$	2.2	1.8 - 2.6	pF
Anode to grid	$C_{a'g'}$	2.3	1.9 - 2.7	pF
Cathode to heater	$C_{kf}$	3.5		pF
Anode to anode other section	$C_{aa'}$		max. 1.3	pF
Grid to grid other section	$C_{gg'}$		max. 0.06	pF

**LIFE**

Production samples are tested to be within the end of life values (column III) under the following conditions during 10 000 hours.

Anode supply voltage	$V_{ba}$	150 V
Grid supply voltage	$V_{bg}$	150 V
Anode resistor	$R_a$	2.6 k $\Omega$
Grid resistor	$R_g$	1.5 M $\Omega$ ( $I_g = 100 \mu A$ )
Voltage between cathode and heater (k pos)	$V_{kf}$	200 V

**LIMITING VALUES** (Absolute max. rating system)

Anode voltage	$V_{a0}$	max. 600 V
	$V_a$	max. 275 V
Anode dissipation	$W_a$	max. 2.0 W
Grid, voltage	$-V_g$	max. 100 V
Grid, peak voltage	$-V_{gp}$	max. 200 V
Max. pulse duration = 10 $\mu s$		
Max. duty factor = 0.01		
Grid voltage	$+V_g$	max. 1 V
Grid current	$I_g$	max. 2 mA
Grid, peak current	$I_{gp}$	max. 50 mA
Max. pulse duration = 10 $\mu s$		
Max. duty factor = 0.01		
Cathode current	$I_k$	max. 20 mA
Cathode, peak current	$I_{kp}$	max. 200 mA
Max. pulse duration = 10 $\mu s$		
Max. duty factor = 0.01		

**LIMITING VALUES** (continued)

Voltage between cathode and heater,

Cathode positive (k pos.)	$V_{kf}$	max. 200 V
Cathode negative (k neg.)	$V_{kf}$	max. 100 V
Grid resistor with fixed bias	$R_g$	max. 0.5 MΩ
with automatic bias	$R_g$	max. 1.0 MΩ
Bulb temperature	$t_{bulb}$	max. 170 °C

Heater voltage: The average heater voltage should be 6.3 V. Variations of the heater voltage exceeding the range of 6.0 V to 6.6 V will shorten the tube life. The tolerance of the heater current (column II) should be taken into account.

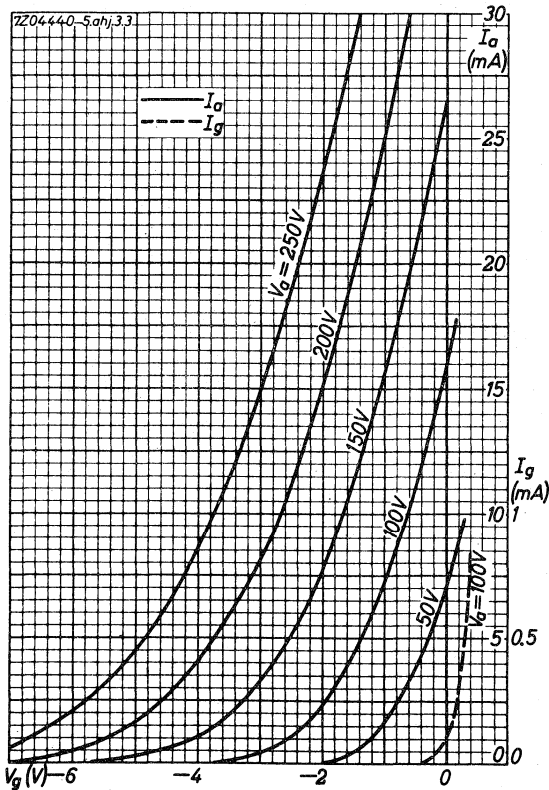

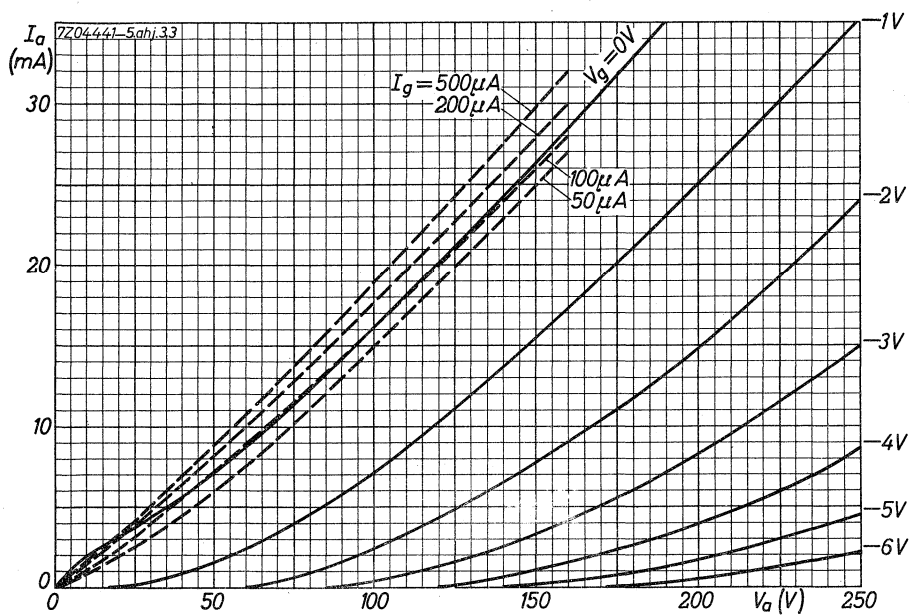

## S.Q. TUBE

Special quality pentode designed for use as wide band amplifier.

### QUICK REFERENCE DATA

Life test	10 000 hours	
Low interface resistance		
Mechanical quality	Shock and vibration resistant	
Base	Noval. Gold plated pins	
Heating	Indirect A. C. or D. C.; parallel supply	
Heater voltage	$V_f$	6.3 V
Heater current	$I_f$	300 mA
Anode current	$I_a$	13 mA
Mutual conductance	$S$	16.5 mA/V
Equivalent noise resistance	$R_{eq}$	330 $\Omega$
Hum voltage	$V_{g1}$ max.	100 $\mu$ V

### DIMENSIONS AND CONNECTIONS

Dimensions in mm

Base: Noval

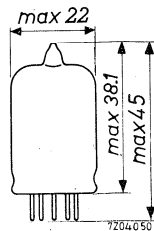
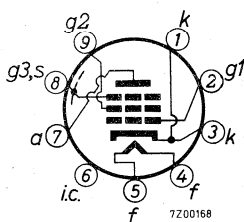

## CHARACTERISTICS

Column I Nominal value or setting of the tube

II Range values for equipment design: Initial spread

III Range values for equipment design: End of life

		I	II	III	
Heater voltage	$V_f$	6.3			V
Heater current	$I_f$	300	285- 315		mA
Anode supply voltage	$V_{ba}$	190			V
Grid No.3 voltage	$V_{g3}$	0			V
Grid No.2 supply voltage	$V_{bg2}$	160			V
Grid No.1 supply voltage	$V_{bg1}$	9			V
Cathode resistor	$R_k$	630			$\Omega$
Anode current	$I_a$	13	12.2-13.8	min. 11.5	mA
Grid No.2 current	$I_{g2}$	3.3	2.9- 3.7		mA
Mutual conductance	S	16.5	14.2-18.8	min. 11	mA/V
Amplification factor grid No.2 to grid No.1	$\mu_{g2g1}$	50			
Internal resistance	$R_i$	90	min. 45		k $\Omega$
Equivalent noise resistance	$R_{eq}$	330	max. 650		$\Omega$
Negative grid No.1 current	$-I_{g1}$		max. 0.5	max. 1.0	$\mu A$
<u>Equivalent grid hum voltage</u>	$V_{g1}$		max. 100		$\mu V_{RMS}$
Grid resistor $R_{g1} = 0.5 M\Omega$					
Centre tap of heater transformer grounded					
<u>Distortion</u>	$d_2$	1.6			%
Load resistor $R_a = 1 k\Omega$					
Input voltage $V_i = 100 mV_{RMS}$					
Cathode heating time		12	max. 18		sec



## CHARACTERISTICS (continued)

		I	II	
Anode supply voltage	$V_{ba}$	180		V
Grid No.3 voltage	$V_{g3}$	0		V
Grid No.2 supply voltage	$V_{bg2}$	150		V
Cathode resistor	$R_k$	100		$\Omega$
Anode current	$I_a$	11.5		mA
Grid No.2 current	$I_{g2}$	2.9		mA
Mutual conductance	S	15.5		mA/V
<u>Cut-off voltage</u>	$-V_{g1}$		max. 4.5	V
Anode voltage	$V_a$	180		V
Grid No.2 voltage	$V_{g2}$	150		V
Grid No.3 voltage	$V_{g3}$	0		V
Anode current	$I_a$	0.8		mA
<u>Start of grid No.1 current</u>	$-V_{g1}$		max. 0.5	V
Grid No.1 current $I_{g1} = 0.3 \mu A$				
<u>Input resistance</u>	$r_{g1}$	2000		$\Omega$
Frequency = 100 MHz				
<u>Phase angle of the slope</u>		9		o
Frequency = 50 MHz				
Pin 1 connected to pin 3				
<u>Leakage current between cathode and heater</u>	$I_{kf}$		max. 15	$\mu A$
Voltage between cathode and heater $V_{kf} = 60 V$				
<u>Insulation resistance between two electrodes</u>			min. 20	M $\Omega$

**CHARACTERISTICS AS TRIODE**

(g<sub>2</sub> connected to anode)

		I	II	
Anode supply voltage	V <sub>ba</sub>	160		V
Grid No.3 voltage	V <sub>g3</sub>	0		V
Grid No.1 voltage	+V <sub>bg1</sub>	9		V
Cathode resistor	R <sub>k</sub>	620		Ω
Anode current	I <sub>a</sub>	16.5		mA
Mutual conductance	S	21		mA/V
Amplification factor	μ	50		
Internal resistance	R <sub>i</sub>	2.4		kΩ
Equivalent noise resistance	R <sub>eq</sub>	225		Ω

**CAPACITANCES** . With external shield

Anode to grid No.3, grid No.2, cathode and heater	C <sub>a/g3g2kf</sub>	3	2.5 - 3.5	pF <sup>1)</sup>
Grid No.1 to grid No.3, grid No.2, cathode and heater				
(I <sub>k</sub> = 0 mA) :	C <sub>g1/g3g2kf</sub>	7.5	6.6 - 8.4	pF <sup>1)</sup>
(I <sub>k</sub> = 16.3 mA, f = 100 MHz) :	C <sub>g1/g3g2kf</sub>	11.1		pF <sup>1)</sup>
Anode to grid No.1	C <sub>ag1</sub>	0.018	max. 0.03	pF
Anode to cathode	C <sub>ak</sub>		max. 0.1	pF
Grid No.1 to heater	C <sub>g1f</sub>		max. 0.1	pF

**SHOCK AND VIBRATION RESISTANCE**

The following test conditions are applied to assess the mechanical quality of the tube. These conditions are not intended to be used as normal-operating conditions.

Shock

The tube is subjected 5 times in each of 4 positions to an acceleration of 500 g supplied by an NRL shock machine with the hammer lifted over an angle of 30°.

Vibration

The tube is subjected during 32 hours in each of 3 positions to a vibration frequency of 50 Hz with an acceleration of 2.5 g.

<sup>1)</sup> Pin No.6 left floating

**LIFE**

Production samples are tested to be within the end of life values (column III) under the following conditions during 10 000 hours.

Anode supply voltage	$V_{ba}$	190 V
Grid No.3 voltage	$V_{g3}$	0 V
Grid No.2 supply voltage	$V_{bg2}$	160 V
Grid No.1 supply voltage	$+V_{bg1}$	9 V
Cathode resistor	$R_k$	630 $\Omega$

**LIMITING VALUES** (Absolute max. rating system)

Anode voltage	$V_{a0}$	max.	400 V
	$V_a$	max.	210 V
Anode dissipation	$W_a$	max.	3 W
Grid No.2 voltage	$V_{g20}$	max.	400 V
	$V_{g2}$	max.	175 V
Grid No.2 dissipation	$W_{g2}$	max.	0.9 W
Cathode current	$I_k$	max.	25 mA
Grid No.1 voltage	$+V_{g1}$	max.	0 V
	$-V_{g1}$	max.	50 V
Grid No.1 peak voltage	$-V_{g1p}$	max.	100 V
Grid resistor, fixed bias	$R_{g1}$	max.	0.25 $M\Omega$
automatic bias	$R_{g1}$	max.	0.5 $M\Omega$
Voltage between cathode and heater	$V_{kf}$	max.	60 V
Bulb temperature	$t_{bulb}$	max.	155 $^{\circ}C$

Heater voltage: The average heater voltage should be 6.3 V.

Variations of the heater voltage exceeding the range of 6.0 V to 6.6 V will shorten the tube life.

The tolerance of heater current (column II) should be taken into account.

7204255

E 180F 18-11-58

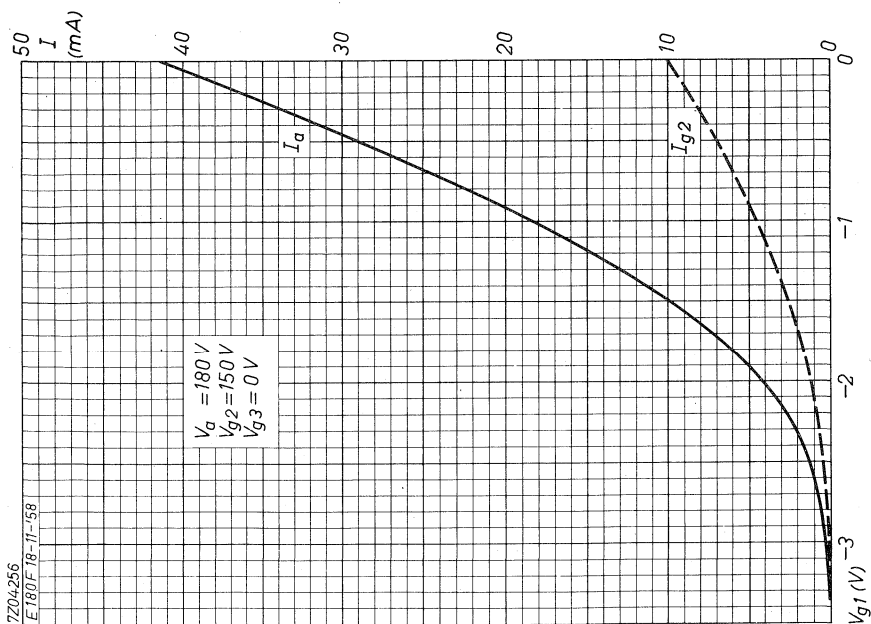
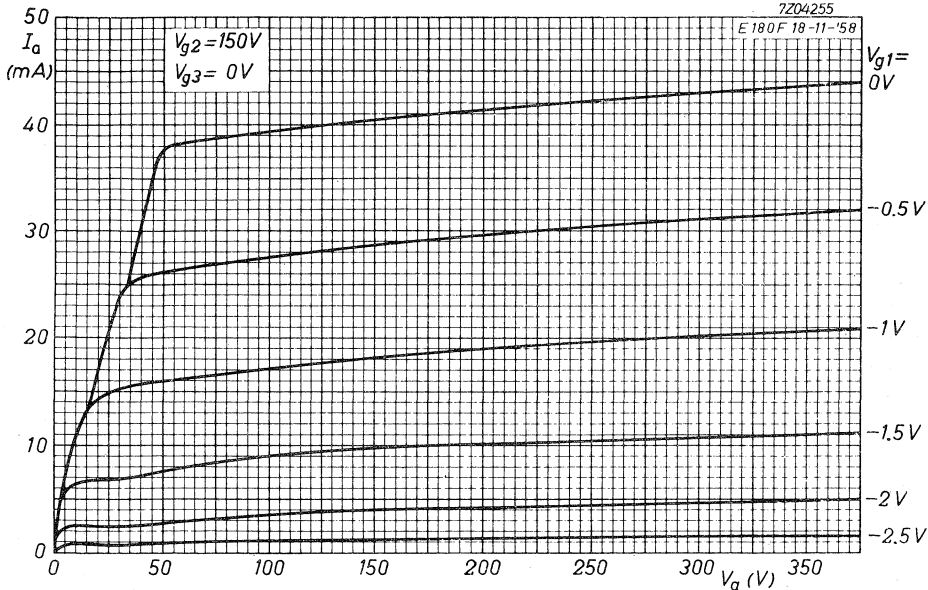

7204256  
E 180F 18-11-58

## S.Q. TUBE

Special quality double triode designed for use in computer circuits.

### QUICK REFERENCE DATA

Life test	10 000 hours	
Low interface resistance		
Base	Noval	
Heating	Indirect A.C. or D.C.; Parallel supply	
Heater voltage	$V_f$	6.3 or 12.6 V
Heater current	$I_f$	640 or 320 mA
Anode current	$I_a$	36 mA
Mutual conductance	S	15 mA/V

### DIMENSIONS AND CONNECTIONS

Dimensions in mm

Base: Noval

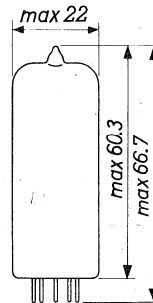
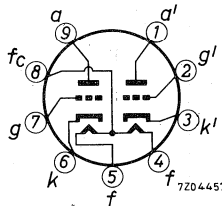

## CHARACTERISTICS

Column I Nominal value or setting of the tube

II Range values for equipment design: Initial spread

III Range values for equipment design: End of life

		I	II	III	
Heater voltage (pin 8 and 4+ 5)	$V_f$	6.3			V
Heater current	$I_f$	640	605- 675		mA
Heater voltage (pin 4 and 5)	$V_f$	12.6			V
Heater current	$I_f$	320			mA
Anode voltage	$V_a$	120			V
Grid voltage	$-V_g$	2			V
Anode current	$I_a$	36	26- 45		mA
Mutual conductance	S	15			mA/V
Amplification factor	$\mu$	24			
Negative grid current	$-I_g$		max. 0.2	max. 1.0	$\mu$ A
Anode voltage	$V_a$	120			V
Cathode resistor	$R_k$	55			$\Omega$
Mutual conductance	S	15	11.2-18.8	min. 8	mA/V
Anode voltage	$V_a$	90			V
Grid current	$I_g$	250			$\mu$ A
Anode current	$I_a$		41- 62	min. 24	mA
<u>Cut-off voltage</u>	$-V_g$	14			V
Anode voltage	$V_a$	150			V
Anode current	$I_a$		max. 0.2		mA
<u>Leakage current between cathode and heater</u>	$I_{kf}$		max. 15	max. 30	$\mu$ A
Voltage between cathode and heater = 200 V					
<u>Insulation resistance between two electrodes</u>			min. 100	min. 20	M $\Omega$

**CAPACITANCES** Each system if applicable

		I	II	
Anode to cathode and heater	$C_{a/kf}$	1.1	0.75-1.45	pF
	$C_{a' / k' f}$	1.0	0.65-1.35	pF
Grid to cathode and heater	$C_{g/kf}$	6.0	5.3- 6.7	pF
Anode to grid	$C_{ag}$	4.0	3.4- 4.6	pF
	$C_{a' g'}$	4.1	3.4- 4.8	pF
Cathode to heater	$C_{kf}$	4.0		pF
Anode to anode other section	$C_{aa'}$	0.6	max. 0.8	pF
Grid to grid other section	$C_{gg'}$		max. 0.15	pF
Anode to grid other section	$C_{ag'}$		max. 0.1	pF

**LIFE**

Production samples are tested to be within the end of life values (column III) during 10 000 hours under the following conditions.

Anode supply voltage	$V_{ba}$	150	V
Anode resistor	$R_a$	1.5	k $\Omega$
Grid supply voltage	$V_{bg}$	150	V
Grid resistor	$R_g$	62	k $\Omega$
Voltage between cathode and heater (cath. neg.)	$V_{kf}$	120	V

**LIMITING VALUES** (Absolute max. rating system)

Anode voltage	$V_{a0}$	max.	600	V
	$V_a$	max.	300	V
Anode dissipation	$W_a$	max.	4.5	W
Anode dissipation (both sections)	$W_{a+a'}$	max.	8.0	W
Grid voltage	$-V_g$	max.	100	V
	$+V_g$	max.	1	V

**LIMITING VALUES** (continued)

Grid voltage, peak	}	$+V_{gp}$	max.	30 V
		$-V_{gp}$	max.	200 V
Pulse duration max. $10 \mu s$				
Duty factor max. 0.01				
Grid current		$I_g$	max.	8 mA
Grid peak current		$I_{gp}$	max.	200 mA
Pulse duration max. $10 \mu s$				
Duty factor max. 0.01				
Cathode current		$I_k$	max.	60 mA
Cathode peak current		$I_{kp}$	max.	400 mA
Pulse duration max. $10 \mu s$				
Duty factor max. 0.01				
Voltage between cathode and heater d.c. component		$V_{kf}$	max.	200 V
		$V_{kf}$	max.	120 V
Bulb temperature		$t_{bulb}$	max.	160 °C
Grid resistor with automatic bias		$R_g$	max.	1 MΩ
Grid resistor with fixed bias		$R_g$	max.	0.5 MΩ

Heater voltage: The average heater voltage should be 6.3/12.6 V.

Variations of the heater voltage exceeding the range of 6.0/12.0 V to 6.6/13.2 V will shorten the tube life.

The tolerance of heater current (column II) should be taken into account.



7Z04454-5.ohb3.3

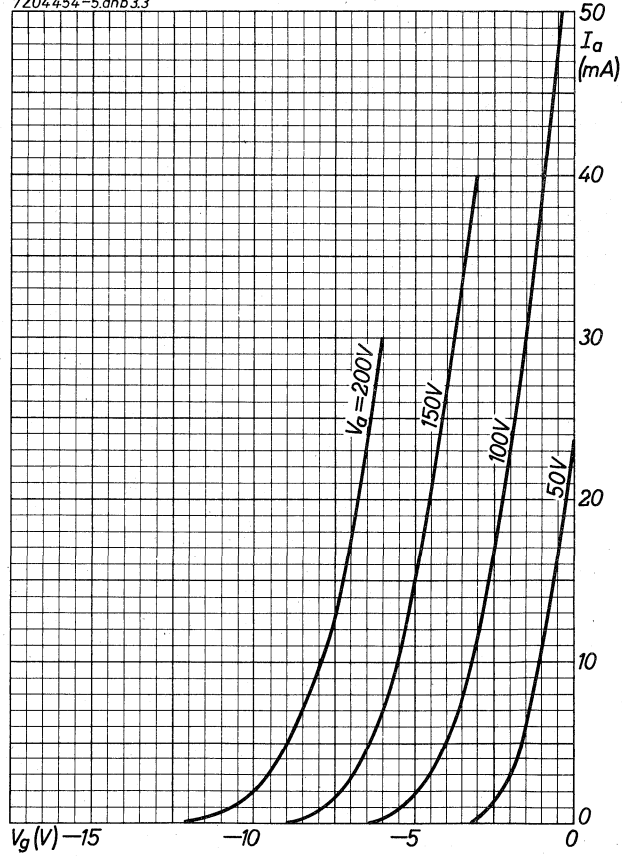

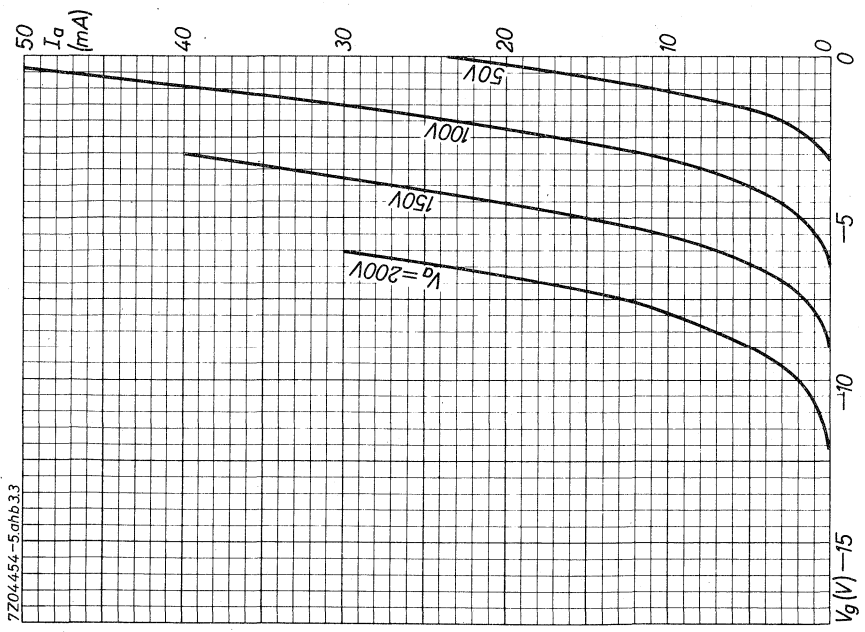
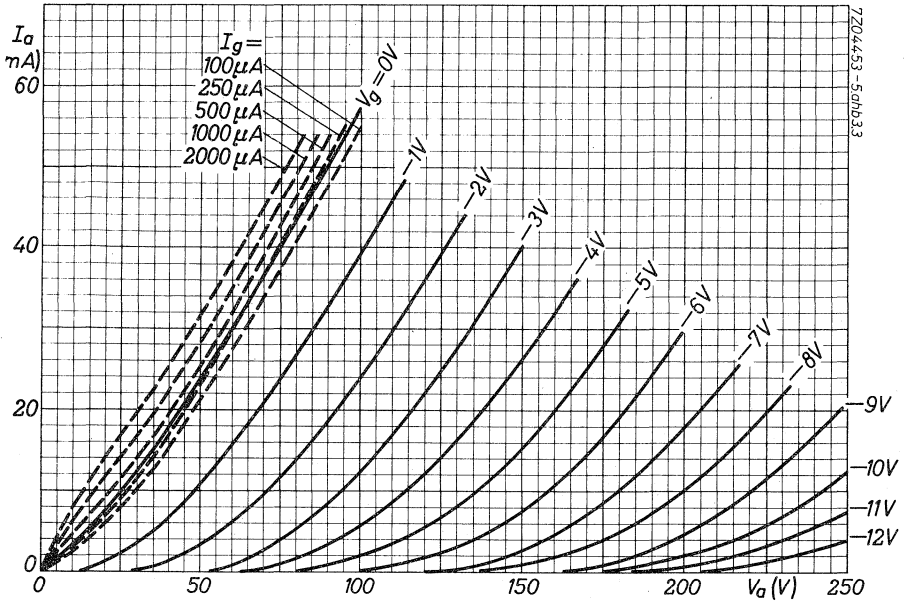

## S.Q. TUBE

Special quality pentode designed for use as broad band amplifier.

QUICK REFERENCE DATA	
Life test	10 000 hours
Mechanical quality	Shock and vibration resistant
Low microphony level	
Base	Noval
Heating	Indirect a.c. or d.c. ; parallel supply
Heater voltage	$V_f$ 6.3 V
Heater current	$I_f$ 320 mA
Anode current	$I_a$ 13 mA
Mutual conductance	S 16.5 mA/V
Equivalent noise resistance	$R_{eq}$ 330 $\Omega$
Hum voltage	$V_{g1}$ <100 $\mu$ V

### DIMENSIONS AND CONNECTIONS

Dimensions in mm

Base: Noval

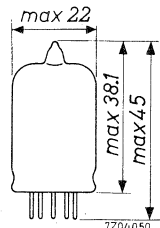
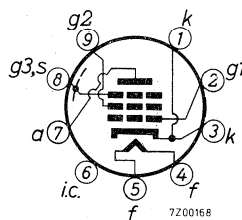

## CHARACTERISTICS

Column I Nominal value or setting of the tube

II Range values for equipment design: Initial spread

III Range values for equipment design: End of life

		I	II	III	
Heater voltage	$V_f$	6.3			V
Heater current	$I_f$	320	300 - 340		mA
Anode supply voltage	$V_{ba}$	190			V
Grid No.3 voltage	$V_{g3}$	0			V
Grid No.2 supply voltage	$V_{bg2}$	160			V
Grid No.1 supply voltage	$+V_{bg1}$	9			V
Cathode resistor	$R_k$	630			$\Omega$
Anode current	$I_a$	13	12.2-13.8	min. 11.5	mA
Grid No.2 current	$I_{g2}$	3.3	2.9 - 3.7		mA
Mutual conductance	S	16.5	14.2-18.6	min. 11	mA/V
Amplification factor grid No.2 to grid No.1	$\mu_{g2g1}$	53			
Internal resistance	$R_i$	100			k $\Omega$
<u>Equivalent noise resistance</u> frequency 45 MHz	$R_{eq}$	330			$\Omega$
<u>Negative grid No.1 current</u>	$-I_{g1}$		max. 0.2	max. 0.5	$\mu A$
Anode supply voltage	$V_{ba}$	180			V
Grid No.3 voltage	$V_{g3}$	0			V
Grid No.2 supply voltage	$V_{bg2}$	150			V
Cathode resistor	$R_k$	100			$\Omega$
Anode current	$I_a$	11.5			mA
Grid No.2 current	$I_{g2}$	2.9			mA
Mutual conductance	S	15.5			mA/V

**CHARACTERISTICS** (continued)

	I	II	III	
<u>Cut-off voltage</u>	$-V_{g1}$	4.5		V
Anode voltage	$V_a$	180		V
Grid No.3 voltage	$V_{g3}$	0		V
Grid No.2 voltage	$V_{g2}$	150		V
Anode current	$I_a$	max. 0.8		mA
<u>Leakage current between cathode and heater</u>	$I_{kf}$	max. 10	max. 20	$\mu A$
Voltage between cathode and heater $V_{kf} = 100$ V				
<u>Insulation resistance between two electrodes</u>	$R_{ins}$	min. 100	min. 50	$M\Omega$
Voltage between electrodes = 100 V				
<u>Hum voltage</u>	$V_{g1}$	max. 100		$\mu V$
Grid No.1 resistor $R_{g1} = 0.5$ $M\Omega$				
Centre tapping of heater transformer grounded				
Cathode resistor by-passed				
<u>Vibrational noise output</u>				
With vibration frequency = 50-2000 Hz	$V_{g1}$	max. 500		$mV_{RMS}$
With vibration frequency = 50 Hz	$V_{g1}$	max. 200		$mV_{RMS}$
Anode supply voltage $V_{b_a} = 216$ V				
Anode resistor $R_a = 2$ $k\Omega$				
Grid No.2 supply voltage $V_{bg_2} = 160$ V				
Grid No.3 voltage $V_{g_3} = 0$ V				
Cathode resistor $R_k = 630$ $\Omega$ (not by-passed)				
Grid No.1 supply voltage $+V_{bg_1} = 9$ V				
Acceleration (peak value) = 10 g				

**CAPACITANCES . With external shield**

Anode to grid No.3, grid No.2  
cathode, heater and screen

	I	II	
$C_{a/g_3g_2kfs}$	3.45		pF

Grid No.1 to grid No.3, grid No.2  
cathode, heater and screen

$C_{g_1/g_3g_2kfs}$	7.6		pF
---------------------	-----	--	----

Anode to grid No.1

$C_{ag_1}$		max.0.03	pF
------------	--	----------	----

**SHOCK AND VIBRATION RESISTANCE**

The following test conditions are applied to assess the mechanical quality of the tube. These conditions are not intended to be used as normal operating conditions.

Shock

The tube is subjected 5 times in each of 4 positions to an acceleration of 500 g supplied by an NRL shock machine with the hammer lifted over an angle of 30°.

Vibration

The tube is subjected during 32 hours in each of 3 positions to a vibration frequency of 50 Hz with an acceleration of 2.5 g.

**LIFE**

Production samples are tested to be within the end of life values (column III) under the following conditions during 10 000 hours.

Anode supply voltage	$V_{ba}$	190	V
Grid No.3 voltage	$V_{g_3}$	0	V
Grid No.2 voltage	$V_{g_2}$	160	V
Grid No.1 supply voltage	$+V_{bg_1}$	9	V
Cathode resistor	$R_k$	630	$\Omega$
Voltage between cathode and heater (cathode negative)	$V_{kf}$	70	V

**LIMITING VALUES** (Absolute max. rating system)

Anode voltage	$V_{a_0}$	max.	400 V
	$V_a$	max.	210 V
Anode dissipation	$W_a$	max.	3 W
Grid No.2 dissipation	$W_{g_2}$	max.	0.7 W
Grid No.2 voltage	$V_{g_{20}}$	max.	400 V
	$V_{g_2}$	max.	175 V
Grid No.1 voltage			
positive	$+V_{g_1}$	max.	0 V
negative	$-V_{g_1}$	max.	50 V
negative peak	$-V_{g_{1p}}$	max.	100 V
Grid No.1 resistor			
fixed bias	$R_{g_1}$	max.	0.25 M $\Omega$
automatic bias	$R_{g_1}$	max.	0.5 M $\Omega$
Cathode current	$I_k$	max.	25 mA
Voltage between cathode and heater	$V_{kf}$	max.	60 V
Bulb temperature	$t_{bulb}$	max.	165 °C

Heater voltage: The average heater voltage should be 6.3 V.

Variation of the heater voltage exceeding the range of 6.0 V to 6.6 V will shorten the tube life.

The tolerance of heater current (column II) should be taken into account.

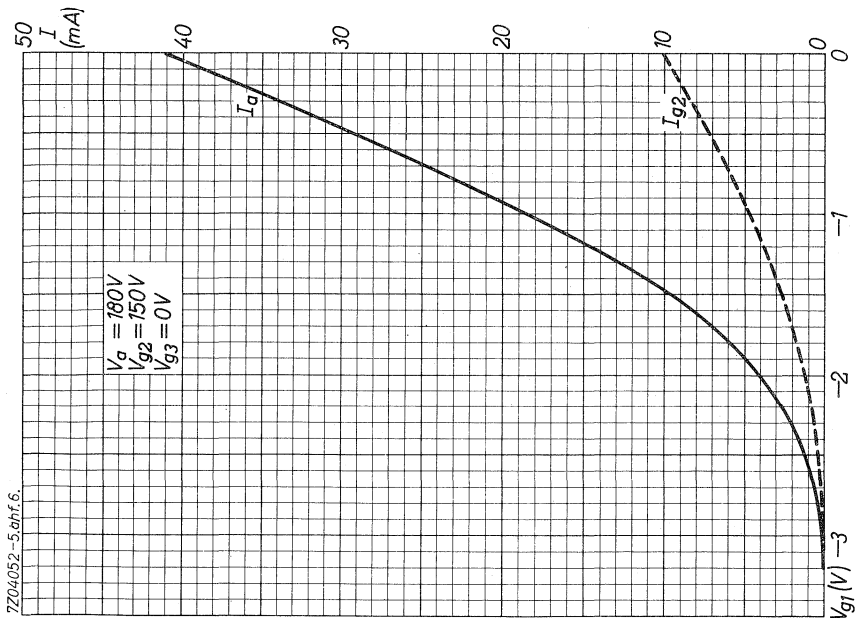
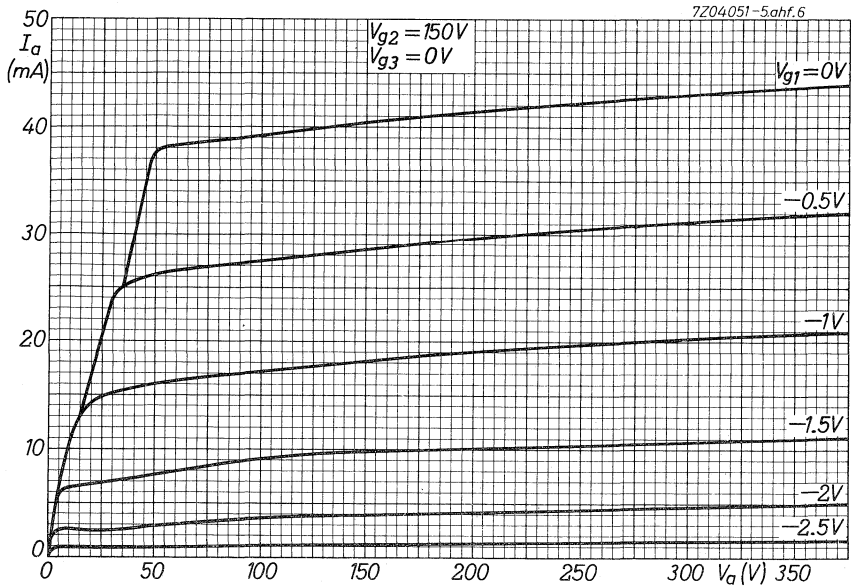



## S.Q. TUBE

Special quality double triode designed for use as cascode amplifier, cathode follower etc. in R.F. and A.F. circuits.

### QUICK REFERENCE DATA

Life test	10 000 hours	
Low interface resistance		
Mechanical quality	Shock and vibration resistant	
Base	Noval. Gold plated pins	
Heating	Indirect A.C. or D.C.; parallel supply	
Heater voltage	$V_f$	6.3 V
Heater current	$I_f$	335 mA
Anode current	$I_a$	15 mA
Mutual conductance	$S$	12.5 mA/V
Equivalent noise resistance	$R_{eq}$	250 $\Omega$
Noise factor ( $f = 200$ MHz)	$F$	4.6 dB
Hum voltage	$V_g$ max.	50 $\mu V_{RMS}$

### DIMENSIONS AND CONNECTIONS

Dimensions in mm

Base: Noval

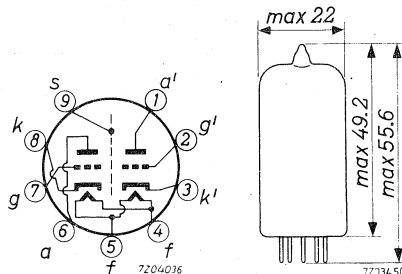

## CHARACTERISTICS

Column I Nominal value or setting of the tube

II Range values for equipment design: Initial spread

III Range values for equipment design: End of life

		I	II	III	
Heater voltage	$V_f$	6.3			V
Heater current	$I_f$	335	318 - 352		mA
Anode supply voltage	$V_{ba}$	100			V
Grid supply voltage	$+V_{bg}$	9			V
Cathode resistor	$R_k$	680			$\Omega$
Anode current	$I_a$	15	14.2-15.8	min. 13.5	mA
Mutual conductance	S	12.5	10.5-14.5	min. 9	mA/V
Amplification factor	$\mu$	33			
<u>Negative grid current</u>	$-I_g$		max. 0.1	max. 1.0	$\mu$ A
<u>Equivalent noise resistance</u>	$R_{eq}$	250			$\Omega$
Frequency f = 45 MHz					
<u>Noise factor in cascode circuit,</u> adapted to minimum noise	F	4.6			dB
Frequency f = 200 MHz					
<u>Input resistance</u>	$r_g$	3			k $\Omega$
Frequency f = 100 MHz					
<u>Cut off voltage</u>	$-V_{g1}$	15			V
Anode voltage	$V_a$	150			V
Anode current	$I_a$		max. 5		mA
Anode supply voltage	$V_{ba}$	90			V
Cathode resistor	$R_k$	120			$\Omega$
Anode current	$I_a$	12			mA
Mutual conductance	S	11.5			mA/V

## CHARACTERISTICS (continued)

	I	II	III	
<u>Leakage current between cathode and heater</u> Voltage between cathode and heater $V_{kf} = 60 \text{ V (k neg)}$ or $= 120 \text{ V (k pos)}$	$I_{kf}$	max. 6	max. 12	$\mu\text{A}$
<u>Insulation resistance between two electrodes</u> Voltage between electrodes $V = 200 \text{ V}$	R	min. 100	min. 20	$\text{M}\Omega$
<u>Hum voltage</u> Grid resistor $R_{g1} = 0.5 \text{ M}\Omega$	$V_g$	max. 50		$\mu\text{V}_{\text{RMS}}$
<u>Vibrational noise output</u> Anode supply voltage $V_{ba} = 100 \text{ V}$ Anode resistor $R_a = 2 \text{ k}\Omega$ Grid supply voltage $+V_{bg} = 9 \text{ V}$ Cathode resistor $R_k = 680 \Omega$ (by passed) Vibration frequency $f = 10\text{-}50 \text{ Hz}$ Acceleration $= 2.5 \text{ g}$	$V_g$	max. 100		mV
<u>Vibrational noise output</u> Anode supply voltage $V_{ba} = 270 \text{ V}$ Anode resistor $R_a = 18 \text{ k}\Omega$ Grid resistor $R_g = 1 \text{ M}\Omega$ Cathode resistor $R_k = 180 \Omega$ By pass capacitor $C_k = 50 \mu\text{F}$ Vibration frequency $f = 50\text{-}5000 \text{ Hz}$ Acceleration $= 0.5 \text{ g}$	$V_g$	max. 140		mV



**CAPACITANCES.** Both sections if not otherwise indicated.

		I	II	
Anode to cathode, heater and screen	$C_{a/kfs}$	1.75	1.55 - 1.95	pF
	$C_{a' / k' fs}$	1.65	1.45 - 1.85	pF
Anode to cathode and heater	$C_{a/kf}$	0.5	0.4 - 0.6	pF
	$C_{a' / k' f}$	0.4	0.3 - 0.5	pF
Grid to cathode, heater and screen	$C_{g/kfs}$	3.3	2.7 - 3.9	pF
Grid to cathode and heater	$C_{g/kf}$	3.3	2.7 - 3.9	pF
Anode to grid	$C_{ag}$	1.4	1.2 - 1.6	pF
Anode to cathode	$C_{ak}$	0.18	0.14 - 0.22	pF
Cathode to heater	$C_{kf}$	2.6		pF
	$C_{k' f}$	2.7		pF
Anode to screen	$C_{as}$	1.3	1.1 - 1.5	pF
Anode to grid, heater and screen	$C_{a/gfs}$	3.0	2.7 - 3.3	pF
	$C_{a' / gfs}$	2.9	2.6 - 3.2	pF
Cathode to grid, heater and screen	$C_{k/gfs}$	6.0	5.1 - 6.9	pF
Anode to anode other section	$C_{aa'}$	0.025	max.0.045	pF
Grid to grid other section	$C_{gg'}$		max.0.005	pF
Anode to grid other section	$C_{ag'}$		max.0.005	pF
Grid to anode other section	$C_{ga'}$		max.0.005	pF
Grid to cathode other section	$C_{gk'}$		max.0.005	pF
Cathode to grid other section	$C_{kg'}$		max.0.005	pF

### SHOCK AND VIBRATION RESISTANCE

The following test conditions are applied to assess the mechanical quality of the tube. These conditions are not intended to be used as normal operating conditions.

#### Shock

The tube is subjected 5 times in each of 4 positions to an acceleration of 500 g supplied by an NRL shock machine with the hammer lifted over an angle of 30°.

#### Vibration

The tube is subjected during 32 hours in each of 3 positions to a vibration frequency of 50 Hz with an acceleration of 2.5 g.

**LIFE**

Production samples are tested to be within the end of life values (column III) under the following conditions during 10 000 hours.

Anode supply voltage	$V_{ba}$	100 V
Grid supply voltage	$+V_{bg}$	9 V
Cathode resistor	$R_k$	680 $\Omega$
Grid resistor	$R_g$	47 k $\Omega$
Cathode to heater voltage (k neg)	$V_{kf}$	60 V

**LIMITING VALUES** (Absolute max. rating system)

Anode voltage	$V_{a_0}$	max.	550 V	
	$V_a$	max.	250 V	
Anode voltage (Zero anode current)	$V_a(I_a = 0)$	max.	400 V	
Anode dissipation	$W_a$	max.	1.65 W	
	}	$W_a$	max.	2.0 W
Both sections		$W_{a+a'}$	max.	2.2 W
Grid dissipation	$W_g$	max.	30 mW	
Grid voltage	$-V_g$	max.	110 V	
Grid peak voltage	$-V_{gp}$	max.	200 V	
Pulse duration max. 200 $\mu$ s				
Duty factor max. 0.1				
Cathode current	$I_k$	max.	22 mA	
Cathode peak current	$I_{kp}$	max.	110 mA	
Pulse duration max. 200 $\mu$ s				
Duty factor max. 0.1%				
Voltage between cathode and heater				
cathode positive	$V_{kf}(k \text{ pos})$	max.	150 V	
cathode negative	$V_{kf}(k \text{ neg})$	max.	100 V	
Bulb temperature	$t_{bulb}$	max.	165 $^{\circ}$ C	
Grid resistor with fixed bias	$R_g$	max.	0.5 M $\Omega$	
with automatic bias	$R_g$	max.	1.0 M $\Omega$	

## LIMITING VALUES (continued)

Heater voltage: The average heater voltage should be 6.3 V.

Variations of the heater voltage exceeding the range of 6.0 V to 6.6 V will shorten the tube life.

The tolerance of heater current (column II) should be taken into account.

## OPERATING CHARACTERISTICS

### Additive mixer

Anode supply voltage	$V_{ba}$	60	90	150	V
Anode resistor	$R_a$	0	1	3.9	$k\Omega$
Grid resistor	$R_g$	1	1	1	$M\Omega$
Grid oscillator voltage	$V_{osc}$	2	2.5	3	$V_{RMS}$
Anode current	$I_a$	4.7	7.7	11	mA
Conversion conductance	$S_c$	2.9	3.5	4.1	mA/V
Internal resistance	$R_i$	8.3	7	6.1	$k\Omega$

### Output tube class A

Anode voltage	$V_a$		220		V
Load resistance	$R_{a\sim}$		20		$k\Omega$
Negative grid voltage	$-V_g$		6.5		V
Input voltage	$V_i$	0	1.5	4.5	$V_{RMS}$
Anode current	$I_a$	6.5	-	9.2	mA
Output power	$W_o$	-	0.05	0.5	W
Total distortion	$d_{tot}$			7	%

### Output tube class B (two units). Constant sinusoidal input voltage (single tone).

Anode voltage	$V_a$		200		V
Load resistance	$R_{aa\sim}$		22		$k\Omega$
Negative grid voltage	$-V_g$		6		V
Input voltage	$V_i$	0	0.9	4.0	$V_{RMS}$
Anode current	$I_a$	2x5	-	2x9	mA
Output power	$W_o$	-	0.05	1.2	W
Total distortion	$d_{tot}$	-	-	3	%

## OPERATING CHARACTERISTICS (continued)

Output tube class B (two units). Speech and music input voltage

Anode voltage	$V_a$	200		V	
Load resistance	$R_{aa}$	10		$k\Omega$	
Negative grid voltage	$-V_g$	6		V	
Input voltage	$V_i$	0	0.9	4.0	V (rms)
Anode current	$I_a$	2 x 5	-	2 x 13.5	mA
Output power	$W_o$	-	0.05	1.5	W
Total distortion	$d_{tot}$	-	-	4	%

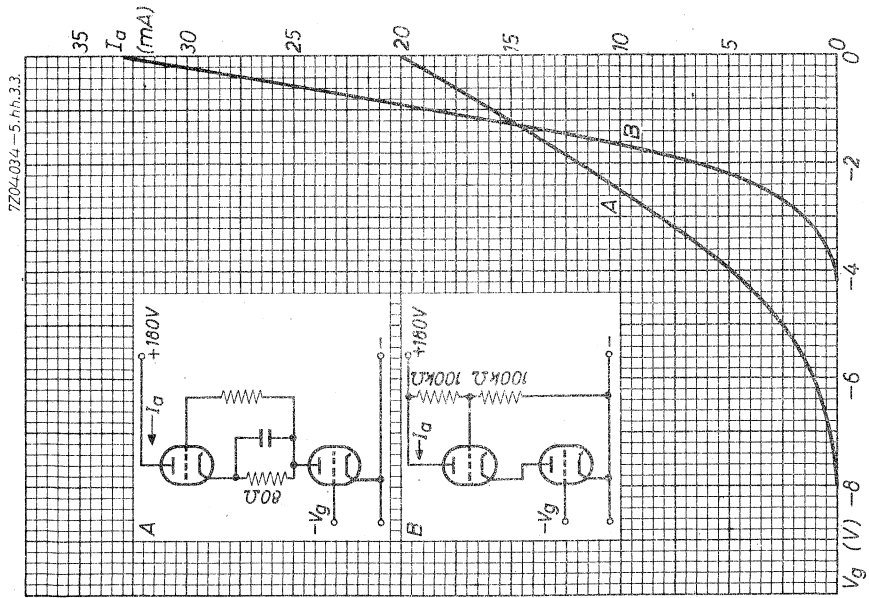
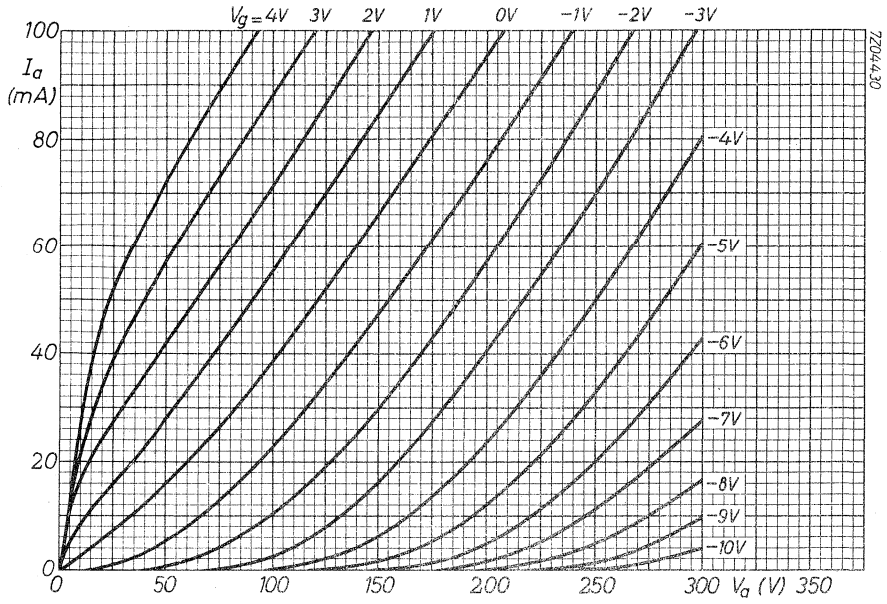



## S.Q. TUBE

Special quality pentode designed for use as wide band amplifier.

### QUICK REFERENCE DATA

Life test	10 000 hours	
Low interface resistance		
Mechanical quality	Shock and vibration resistant	
Base	Noval. Gold plated pins	
Heating	Indirect A.C. or D.C.; Parallel supply	
Heater voltage	$V_f$	6.3 V
Heater current	$I_f$	315 mA
Anode current	$I_a$	20 mA
Transconductance	$S$	26 mA/V
Equivalent noise resistance	$R_{eq}$	220 $\Omega$

### DIMENSIONS AND CONNECTIONS

Dimensions in mm

Base: Noval

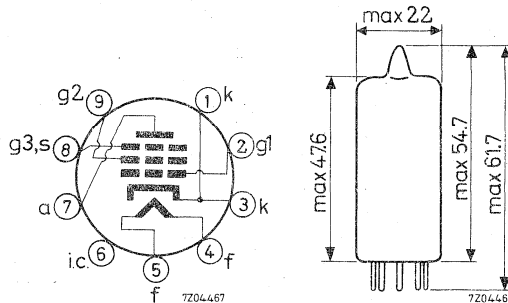

## CHARACTERISTICS

Column I Nominal value or setting of the tube

II Range values for equipment design: Initial spread

III Range values for equipment design: End of life

		I	II	III	
Heater voltage	$V_f$	6.3			V
Heater current	$I_f$	315	299- 331		mA
Anode supply voltage	$V_{ba}$	190			V
Grid No.2 supply voltage	$V_{bg_2}$	160			V
Grid No.3 voltage	$V_{g_3}$	0			V
Grid No.1 supply voltage	$+V_{bg_1}$	8			V
Cathode resistor	$R_k$	370			$\Omega$
Anode current	$I_a$	20	18.8-21.2	min. 17	mA
Grid No.2 current	$I_{g_2}$	6	5.3- 6.7		mA
Mutual conductance	$S$	26	22- 30	min.17.5	mA/V
Internal resistance	$R_i$	100			k $\Omega$
Amplification factor	$\mu_{g_2g_1}$	60			
Negative grid current	$-I_{g_1}$		max. 0.3	max. 1.0	$\mu$ A
Equivalent noise resistance	$R_{eq}$	220			$\Omega$
Input resistance	$r_{g_1}$	1.4			k $\Omega$
Pin 1 connected to pin 3					
Frequency 100 MHz					
S/C		2.2			mA/V/pF
$S/2\pi(C_g + C_a + 5 \text{ pF})$		180			MHz
Anode supply voltage	$V_{ba}$	180			V
Grid No.2 supply voltage	$V_{bg_2}$	150			V
Grid No.3 voltage	$V_{g_3}$	0			V
Cathode resistor	$R_k$	80			$\Omega$
Anode current	$I_a$	17			mA
Grid No.2 current	$I_{g_2}$	5.1			mA
Mutual conductance	$S$	24.5			mA/V

**CHARACTERISTICS** (continued)

As triode (grid No.2 connected to anode,  
grid No.3 connected to cathode)

		I	
Anode supply voltage	$V_a$	160	V
Grid No.1 supply voltage	$+V_{bg1}$	8	V
Cathode resistor	$R_k$	400	$\Omega$
Anode current	$I_a$	24	mA
Mutual conductance	S	33	mA/V
Internal resistance	$R_i$	1.8	k $\Omega$
Amplification factor	$\mu$	60	
Equivalent noise resistance	$R_{eq}$	100	$\Omega$

**CAPACITANCES**

		Without external shield		With external shield		
		I	II	I	II	
Grid No.1 to grid No.2, grid No.3, cathode, heater and screen	$C_{g1/g2g3kfs}$	9.3	8.3-10.3	9.4	8.4-10.4	pF
Anode to grid No.2, grid No.3, cathode, heater and screen	$C_{a/g2g3kfs}$	2.6	2.3- 2.9	3.6	3.2- 4.0	pF
Anode to grid No.1	$C_{ag1}$		max. 35		max. 30	mpF
Grid No.1 to grid No.2, grid No.3, cathode, heater and screen	$C_{g1/g2g3kfs}$	15.5		15.6		pF

Cathode current  
 $I_k = 26$  mA

**SHOCK AND VIBRATION RESISTANCE**

The following test conditions are applied to assess the mechanical quality of the tube. These conditions are not intended to be used as normal operating conditions.

Shock

The tube is subjected 5 times in each of 4 positions to an acceleration of 500 g supplied by an NRL shock machine with the hammer lifted over an angle of 30°.

Vibration

The tube is subjected during 32 hours in each of 3 positions to a vibration frequency of 50 Hz with an acceleration of 2.5 g.

**LIFE**

Production samples are tested to be within the end of life values (column III) during 10 000 hours.

**LIMITING VALUES** (Absolute max. rating system)

Anode voltage	$V_{a_0}$	max.	400 V
	$V_a$	max.	220 V
Anode dissipation	$W_a$	max.	4 W
	$V_{g_{20}}$	max.	400 V
Grid No.2 voltage	$V_{g_2}$	max.	180 V
	$W_{g_2}$	max.	1.1 W
Grid No.2 dissipation			
Cathode current	$I_k$	max.	30 mA
	$I_{g_1}$	max.	5 mA
Grid No.1 current			
	$-V_{g_1}$	max.	50 V
Grid No.1 voltage negative			
	$+V_{g_1}$	max.	2 V
Grid No.1 voltage positive			
	$R_{g_1}$	max.	0.5 M $\Omega$
Grid No.1 resistor			
Voltage between cathode and heater			
cathode positive	$V_{kf}(k \text{ pos})$	max.	120 V
	$V_{kf}(k \text{ neg})$	max.	60 V
cathode negative			
Bulb temperature	$t_{bulb}$		180 °C

Heater voltage: The average heater voltage should be 6.3 V.

Variation of the heater voltage exceeding the range of 6.0 V to 6.6 V will shorten the tube life.

The tolerance of heater current should be taken into account.

**OPERATING CHARACTERISTICS**

Anode supply voltage	$V_{ba}$	190	190	190	190	190	V
Grid No.3 voltage	$V_{g_3}$	0	0	0	0	0	V
Grid No.2 supply voltage	$V_{bg_2}$	160	160	160	160	120	V
Grid No.1 supply voltage	$+V_{bg_1}$	8	8	8	9	8	V
Cathode resistor	$R_k$	370	500	780	630	730	$\Omega$
Anode current	$I_a$	20	15	10	13.5	10	mA
Grid No.2 current	$I_{g_2}$	6	4.5	3	4	2.8	mA
Mutual conductance	$S$	26	23	19	22	20	mA/V
Internal resistance	$R_i$	100	120	155	130	155	k $\Omega$
Amplification factor	$\mu_{g_2g_1}$	60	58	56	58	56	
Equivalent noise resistance	$R_{eq}$	220	230	250	240	220	$\Omega$
<u>Input resistance</u>	$r_{g_1}$	1.4	1.5	1.7	1.6	1.6	k $\Omega$

Pin No.1 connected  
to pin No.3

Frequency = 100 MHz

Capacitance grid No.1  
to grid No.2, grid No.3,  
cathode, heater and  
screen (no external  
shield)

$C_{g_1/g_2g_3kfs}$	15.5	15	14.3	14.8	14.8	pF
$S/2 \pi(C_g + C_a + 5 \text{ pF})$	180	162	138	156	142	MHz
$S/C$	2.2	1.9	1.6	1.85	1.7	mA/V/pF

7Z01723|5bhj6

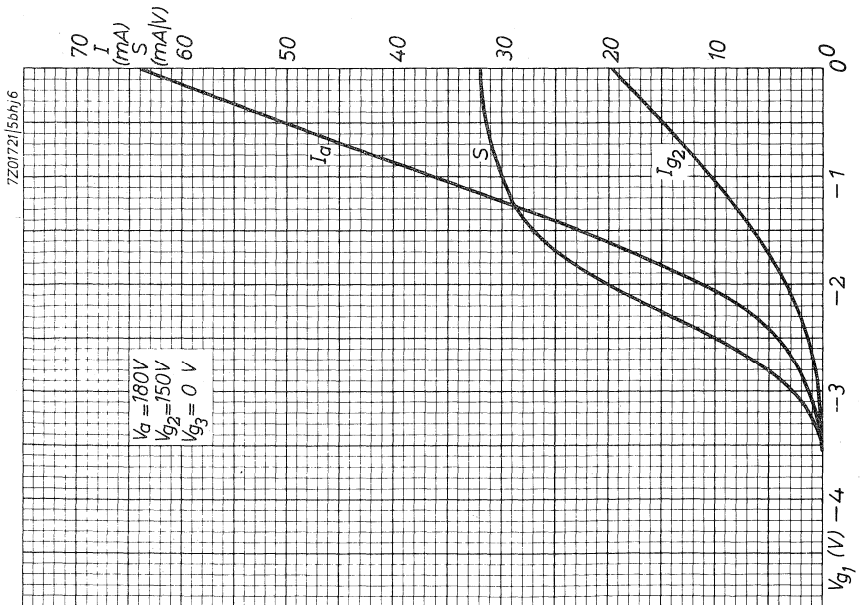
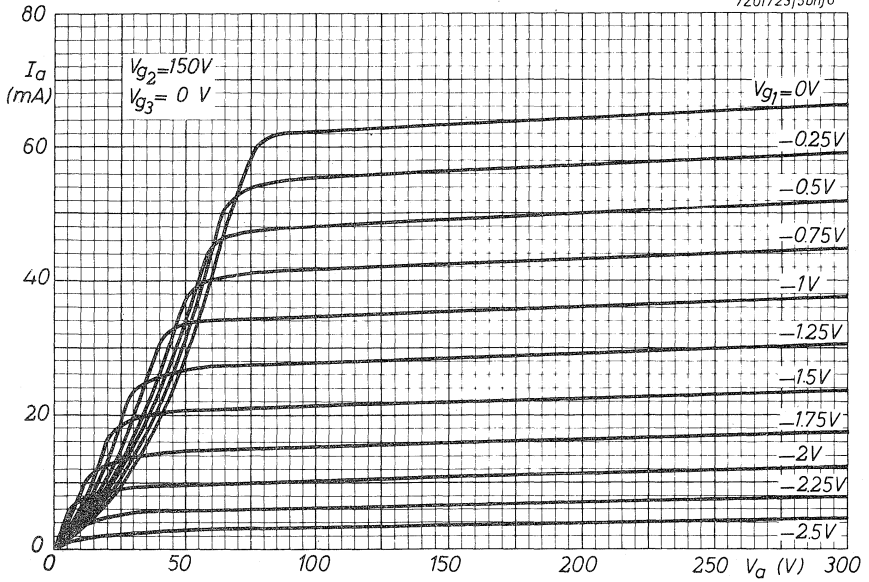

**S.Q. TUBE**

Special quality pentode designed for use as wide band amplifier for frequencies up to 250 MHz

QUICK REFERENCE DATA	
Life test	10 000 hours
Low interface resistance	
Mechanical quality	Shock and vibration resistant
Base	Noval. Gold plated pins
Heating	Indirect A. C. or D. C.; parallel supply
Heater voltage	$V_f$ 6.3 V
Heater current	$I_f$ 350 mA
Anode current	$I_a$ 35 mA
Mutual conductance	$S$ 26 mA/V
Equivalent noise resistance	$R_{eq}$ 200 $\Omega$
Noise factor at 100 MHz	$F$ 7 dB

**DIMENSIONS AND CONNECTIONS**

Dimensions in mm

Base: Noval

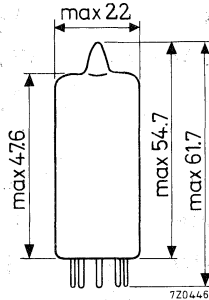
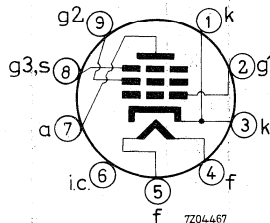

## CHARACTERISTICS

Column I Nominal value or setting of the tube

II Range values for equipment design: Initial spread

III Range values for equipment design: End of life

		I	II	III	
Heater voltage	$V_f$	6.3			V
Heater current	$I_f$	350			mA
Anode supply voltage	$V_{ba}$	125			V
Grid No. 2 supply voltage	$V_{bg_2}$	125			V
Grid No. 3 voltage	$V_{g_3}$	0			mA/V
Grid No. 1 supply voltage	$+V_{bg_1}$	12			V
Cathode resistor	$R_k$	300			$\Omega$
Anode current	$I_a$	35	33 - 37	min. 31	mA
Grid No. 2 current	$I_{g_2}$	11	9.9 - 12.1		mA
Mutual conductance	$S$	26	22 - 30	min. 17.5	mA/V
Amplification factor	$\mu_{g_2g_1}$	27			
Equivalent noise resistance	$R_{eq}$	200			$\Omega$
Noise factor at 100 MHz	$F$	7			dB
Adapted to minimum noise					
Negative grid current	$-I_{g_1}$		max. 0.3	max. 1.0	$\mu A$
Anode supply voltage	$V_{ba}$	135			V
Grid No. 2 supply voltage	$V_{bg_2}$	125			V
Grid No. 3 voltage	$V_{g_3}$	0			V
Grid No. 1 supply voltage	$+V_{bg_1}$	12			V
Cathode resistor	$R_k$	360			$\Omega$
Anode current	$I_a$	30			mA
Grid No. 2 current	$I_{g_2}$	9.5			mA
Mutual conductance	$S$	25			mA/V
Amplification factor	$\mu_{g_2g_1}$	27			
Equivalent noise resistance	$R_{eq}$	200			$\Omega$



**CHARACTERISTICS** (continued)

As triode (grid No. 2 connected to anode)  
(grid No. 3 connected to cathode)

		I	II	
Anode supply voltage	$V_{ba}$	125		V
Grid No. 3 supply voltage	$V_{bg_3}$	0		V
Grid No. 1 supply voltage	$+V_{bg_1}$	12		V
Cathode resistor	$R_k$	350		$\Omega$
Anode current	$I_a$	40		mA
Mutual conductance	$S$	32		mA/V
Amplification factor	$\mu$	25.5		
Internal resistance	$R_i$	800		$\Omega$
Equivalent noise resistance	$R_{eq}$	100		$\Omega$
<u>Leakage current between cathode and heater</u>	$I_{kf}$		max. 5	$\mu A$
Voltage between cathode and heater $V_{kf} = 100$ V				
<u>Insulation resistance</u>				
Anode to other electrodes (V = 300 V)	R		min. 100	$M\Omega$
Grid No. 1 to other electrodes (V = 50 V)	R		min. 100	$M\Omega$
<b>CAPACITANCES</b>				
Grid No. 1 to grid No. 2, grid No. 3 cathode, heater and screen	$C_{g_1/g_2g_3kfs}$	10		pF
Grid No. 1 to grid No. 2, grid No. 3 cathode, heater and screen	$C_{g_1/g_2g_3kfs}$	16		pF
Cathode current $I_k = 46$ mA				
Anode to grid No. 2, grid No. 3 cathode, heater and screen	$C_{a/g_2g_3kfs}$	2.6		pF
Anode to grid No. 1	$C_{ag_1}$		max. 50	mpF
Anode to cathode	$C_{ak}$		max. 50	mpF
Cathode to heater	$C_{kf}$	4.7		pF
Grid No. 1 to heater	$C_{g_1f}$		max. 50	mpF
Anode to heater	$C_{af}$		max. 100	mpF

**SHOCK AND VIBRATION RESISTANCE**

The following test conditions are applied to assess the mechanical quality of the tube. These conditions are not intended to be used as normal operating conditions.

Shock

The tube is subjected 5 times in each of 4 positions to an acceleration of 500 g supplied by an NRL shock machine with the hammer lifted over an angle of 30°.

Vibration

The tube is subjected during 32 hours in each of 3 positions to a vibration frequency of 50 Hz with an acceleration of 2.5 g.

**LIFE**

Production samples are tested to be within the end of life values (column III) during 10 000 hours.

**LIMITING VALUES** (Absolute max. rating system)

Anode voltage	$V_{a_0}$	max.	400 V
	$V_a$	max.	200 V
Anode dissipation	$W_a$	max.	4.2 W
Grid No. 2 voltage	$V_{g_{20}}$	max.	400 V
	$V_{g_2}$	max.	150 V
Grid No. 2 dissipation <sup>1)</sup>	$W_{g_2}$	max.	1.4 W
Grid voltage	$-V_g$	max.	50 V
Grid resistor, automatic bias	$R_{g_1}$	max.	0.5 MΩ
Cathode current	$I_k$	max.	50 mA
Voltage between cathode and heater	$V_{kf}$	max.	100 V
Bulb temperature	$t_{bulb}$	max.	180 °C

Heater voltage: The average heater voltage should be 6.3 V.

Variations of the heater voltage exceeding the range of 6.0 V to 6.6 V will shorten the tube life.

The tolerance of heater current should be taken into account.

<sup>1)</sup> Grid No. 2 dissipation: Care should be taken not to exceed the limiting value during switching in of positive voltages. If the cathode resistor is shunted by more than 10 μF a grid No. 1 series resistor of minimum 1 kΩ should be applied.

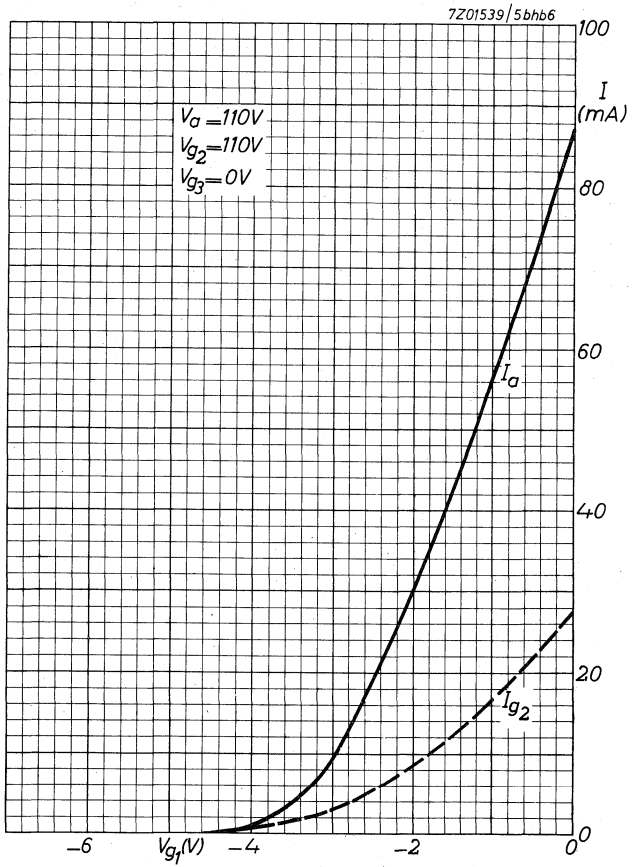

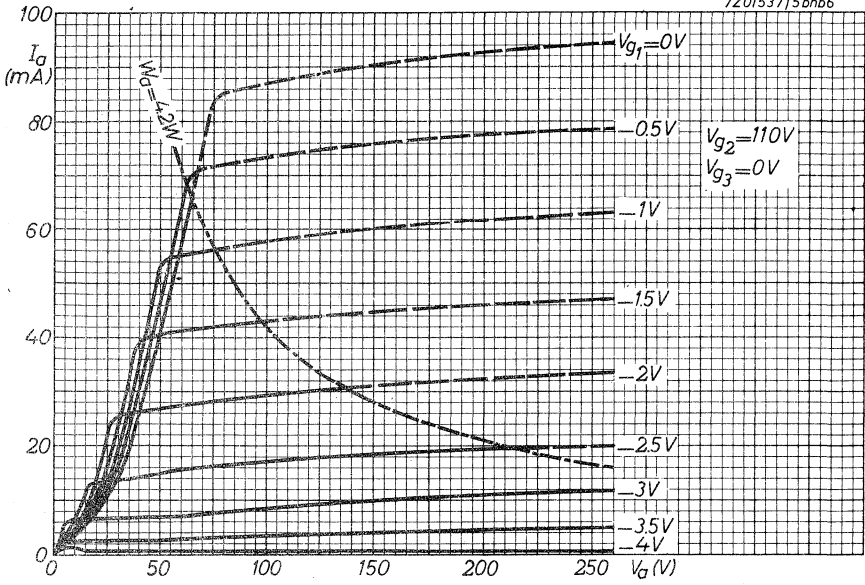

## S.Q. TUBE

Special quality double triode designed for use as A. F. amplifier.

### QUICK REFERENCE DATA

Life test	10 000 hours		
Low interface resistance			
Mechanical quality	Shock and vibration resistant		
Base	Noval		
Heating	Indirect A. C. or D. C.; parallel supply		
Heater voltage	$V_f$	6.3	V
Heater current	$I_f$	330	mA
Anode current	$I_a$	1.25	mA
Mutual conductance	$S$	1.6	mA/V
Amplification factor	$\mu$	100	
Hum voltage	Section 1	$V_g$	max. 5 $\mu$ V <sub>RMS</sub>
		Section 2	$V_g$ max. 15 $\mu$ V <sub>RMS</sub>

### DIMENSIONS AND CONNECTIONS

Dimensions in mm

Base: Noval

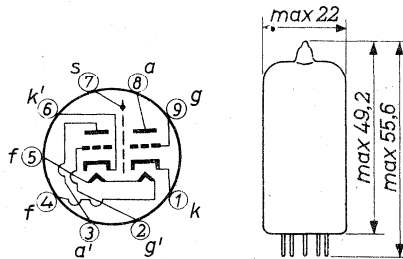

**CHARACTERISTICS**

- Column I Nominal value or setting of the tube
- II Range values for equipment design: Initial spread
- III Range values for equipment design: End of life

		I	II	III	
Heater voltage	$V_f$	6.3			V
Heater current	$I_f$	330	313 - 347		mA
Anode voltage	$V_a$	250			V
Cathode resistor	$R_k$	1.6			$k\Omega$
Anode current	$I_a$	1.25	1.1 - 1.4	min. 0.8	mA
Mutual conductance	S	1.6	1.3 - 1.95	min. 1.05	mA/V
Amplification factor	$\mu$	100			
Internal resistance	$R_i$	62.5			$k\Omega$
<u>Negative grid current</u>	$-I_g$		max. 0.2	max. 0.5	$\mu A$
Anode voltage	$V_a$	100			V
Cathode resistor	$R_k$	2			$k\Omega$
Anode current	$I_a$	0.5			mA
Mutual conductance	S	1.25			mA/V
Amplification factor	$\mu$	100			
Internal resistance	$R_i$	80			$k\Omega$
<u>Cut-off voltage</u>	$-V_g$		max. 4		V
Anode voltage	$V_a$	250			V
Anode current	$I_a$	20			$\mu A$
<u>Grid current starting voltage</u>	$-V_g$		max. 1		V
Grid current $+I_g = 0.3 \mu A$					
<u>Leakage current between cathode and heater</u>	$I_{kf}$		max. 5		$\mu A$
Voltage between cathode and heater $V_{kf} = 100 V$					

**CHARACTERISTICS** (continued)

Insulation resistance between electrodes

Anode to all other electrodes  
(Voltage between electrodes 300 V)

Grid to all other electrodes  
(Voltage between electrodes 100 V)

		II	
R	min. 300	MΩ	
R	min. 300	MΩ	
$V_g$	max. 5	$\mu V_{RMS}$	
$V_{g'}$	max. 15	$\mu V_{RMS}$	
$V_g$	max. 10	mV	

Hum voltage Section 1  
Section 2

Anode supply voltage  $V_{ba} = 250$  V

Anode resistor  $R_a = 100$  kΩ

Grid resistor  $R_g = 1$  MΩ

Vibrational noise

Anode voltage  $V_a = 250$  V

Grid voltage  $-V_g = 2$  V

Anode resistor  $R_a = 5$  kΩ

Frequency  $f = 25$  Hz

Acceleration = 2.5 g

Microphony

The sensitivity of the amplifier circuit for 50 mW should not exceed 0.5 mV.

**CAPACITANCES** Each system if applicable

Grid to cathode heater and screen	$C_{g/kfs}$	2.0	pF
Anode to cathode and screen	$C_{a/kfs}$	2.0	pF
Anode to grid	$C_{ag}$	1.2	pF
Grid to heater	$C_{gf}$	max. 0.01	pF
	$C_{g'f}$	max. 0.02	pF
Grid to grid other section	$C_{gg'}$	max. 0.01	pF
Anode to anode other section	$C_{aa'}$	max. 0.1	pF
Anode to grid other section	$C_{ag'}$	max. 0.06	pF
	$C_{a'g}$	max. 0.01	pF

## SHOCK AND VIBRATION RESISTANCE

The following test conditions are applied to assess the mechanical quality of the tube. These conditions are not intended to be used as normal operating conditions.

### Shock

The tube is subjected 5 times in each of 4 positions to an acceleration of 500 g supplied by an NRL shock machine with the hammer lifted over an angle of 30°.

### Vibration

The tube is subjected during 32 hours in each of 3 positions to a vibration frequency of 50 Hz with an acceleration of 2.5 g.

## LIFE

Production samples are tested to be within the end of life values (column III) during 10 000 hours.

### LIMITING VALUES (Absolute max. rating system)

Anode voltage	$V_{a0}$	max.	600 V
	$V_a$	max.	300 V
Anode dissipation	$W_a$	max.	1.2 W
Grid voltage	$-V_g$	max.	55 V
	$+V_g$	max.	0.5 V
Grid resistor with fixed bias	$R_g$	max.	1.2 M $\Omega$
with autom. bias	$R_g$	max.	2.2 M $\Omega$
Cathode current	$I_k$	max.	9 mA
Voltage between cathode and heater	$V_{kf}$	max.	200 V
Bulb temperature	$t_{bulb}$	max.	170 °C
Resistance of cathode to heater circuit in case of phase inverter circuit	$R_{kf}$	max.	135 k $\Omega$

Heater voltage: The average heater voltage should be 6.3 V.

Variations of the heater voltage exceeding the range of 6.0 V to 6.6 V will shorten the tube life.

The tolerance of heater current (column II) should be taken into account.



## OPERATING CHARACTERISTICS

A.F. amplifier Fig.1 see page 8

Anode supply voltage	$V_{ba}$	200	250	300	350	400	V
Anode resistor	$R_a$	47	47	47	47	47	k $\Omega$
Cathode resistor	$R_k$	1500	1200	1000	820	680	$\Omega$
Grid resistor next stage	$R_o$	150	150	150	150	150	k $\Omega$
Anode current	$I_a$	0.86	1.18	1.55	1.98	2.45	mA
Output voltage at $+I_g = 0.3 \mu A$	$V_o$	18	23	26	33	37	V <sub>RMS</sub>
Voltage gain	$V_o/V_i$	34	37.5	40	42.5	44	
Total distortion 1)	$d_{tot}$	8.5	7.0	5.0	4.4	3.6	%
Anode voltage	$V_{ba}$	200	250	300	350	400	V
Anode resistor	$R_a$	100	100	100	100	100	k $\Omega$
Cathode resistor	$R_k$	1800	1500	1200	1000	820	$\Omega$
Grid resistor next stage	$R_o$	330	330	330	330	330	k $\Omega$
Anode current	$I_a$	0.65	0.86	1.11	1.40	1.72	mA
Output voltage at $+I_g = 0.3 \mu A$	$V_o$	20	26	30	36	38	V <sub>RMS</sub>
Voltage gain	$V_o/V_i$	50	54.5	57	61	63	
Total distortion 1)	$d_{tot}$	4.8	3.9	2.7	2.2	1.7	%
Anode supply voltage	$V_{ba}$	200	250	300	350	400	V
Anode resistor	$R_a$	220	220	220	220	220	k $\Omega$
Cathode resistor	$R_k$	3300	2700	2200	1500	1200	$\Omega$
Grid resistor next stage	$R_o$	680	680	680	680	680	k $\Omega$
Anode current	$I_a$	0.36	0.48	0.63	0.85	1.02	mA
Output voltage at $+I_g = 0.3 \mu A$	$V_o$	24	28	36	37	38	V <sub>RMS</sub>
Voltage gain	$V_o/V_i$	56	66.5	72	75.5	76.5	
Total distortion 1)	$d_{tot}$	4.6	3.4	2.6	1.6	1.1	%

1) The distortion is about proportional to the output voltage.

## OPERATING CHARACTERISTICS (continued)

A.F. amplifier Fig.2 see page 9 Input source resistance = 100  $\Omega$ 

Anode supply voltage	$V_{ba}$	200	250	300	350	400	V
Anode resistor	$R_a$	47	47	47	47	47	$k\Omega$
Grid resistor next stage	$R_o$	150	150	150	150	150	$k\Omega$
Anode current	$I_a$	1.02	1.45	2.02	2.50	3.10	mA
Output voltage	$V_o$	18	23	26	33	37	$V_{RMS}$
Voltage gain	$V_o/V_i$	37	39	41	44	45	
Total distortion <sup>1)</sup>	$d_{tot}$	5.6	4.2	2.9	2.7	2.5	%
<hr/>							
Anode supply voltage	$V_{ba}$	200	250	300	350	400	V
Anode resistor	$R_a$	100	100	100	100	100	$k\Omega$
Grid resistor next stage	$R_o$	330	330	330	330	330	$k\Omega$
Anode current	$I_a$	0.7	1.00	1.29	1.62	1.95	mA
Output voltage	$V_o$	20	26	30	36	38	$V_{RMS}$
Voltage gain	$V_o/V_i$	50	51	54	56	58	
Total distortion <sup>1)</sup>	$d_{tot}$	3.9	2.6	2.0	1.8	1.6	%
<hr/>							
Anode supply voltage	$V_{ba}$	200	250	300	350	400	V
Anode resistor	$R_a$	220	220	220	220	220	$k\Omega$
Grid resistor next stage	$R_o$	680	680	680	680	680	$k\Omega$
Anode current	$I_a$	0.39	0.56	0.74	0.88	1.09	mA
Output voltage	$V_o$	24	28	36	37	38	$V_{RMS}$
Voltage gain	$V_o/V_i$	58	62	66	67	68	
Total distortion <sup>1)</sup>	$d_{tot}$	4.6	2.7	2.2	1.7	1.4	%

<sup>1)</sup> The distortion is about proportional to the output voltage.

**OPERATING CHARACTERISTICS (continued)**

A. F. amplifier Fig. 3 see page 9 Input source resistance = 330 kΩ

Anode supply voltage	$V_{ba}$	100	150	200	250	300	350	400	V
Anode resistor	$R_a$	47	47	47	47	47	47	47	kΩ
Grid resistor next stage	$R_o$	150	150	150	150	150	150	150	kΩ
Anode current	$I_a$	0.35	0.84	1.40	1.95	2.52	3.19	3.80	mA
Voltage gain	$V_o/V_i$	25	33	34	36	38	40	41	

Total distortion at:

$V_o = 2$ V	$d_{tot}$	1.7	2.5	2.4	2.3	2.2	2.2	2.1	%
$V_o = 4$ V	$d_{tot}$	2.1	4.6	4.7	4.6	4.5	4.2	4.2	%
$V_o = 6$ V	$d_{tot}$	6.0	5.2	5.6	5.6	5.5	5.5	5.4	%

Anode supply voltage	$V_{ba}$	100	150	200	250	300	350	400	V
Anode resistor	$R_a$	100	100	100	100	100	100	100	kΩ
Grid resistor next stage	$R_o$	330	330	330	330	330	330	330	kΩ
Anode current	$I_a$	0.24	0.56	0.88	1.23	1.58	1.92	2.29	mA
Voltage gain	$V_o/V_i$	34	43	46	48	50	51	52	

Total distortion at:

$V_o = 2$ V	$d_{tot}$	1.6	1.9	1.9	1.8	1.8	1.8	1.7	%
$V_o = 4$ V	$d_{tot}$	2.3	3.0	3.8	3.8	3.6	3.6	3.5	%
$V_o = 6$ V	$d_{tot}$	2.5	4.7	5.1	5.1	5.0	4.9	4.8	%

Anode supply voltage	$V_{ba}$	100	150	200	250	300	350	400	V
Anode resistor	$R_a$	220	220	220	220	220	220	220	kΩ
Grid resistor next stage	$R_o$	680	680	680	680	680	680	680	kΩ
Anode current	$I_a$	0.14	0.32	0.49	0.67	0.85	1.05	1.23	mA
Voltage gain	$V_o/V_i$	42	51	54	57	58	59	60	

Total distortion at:

$V_o = 2$ V	$d_{tot}$	1.6	1.7	1.7	1.6	1.6	1.6	1.6	%
$V_o = 4$ V	$d_{tot}$	2.5	3.0	3.0	2.9	2.9	2.8	2.7	%
$V_o = 6$ V	$d_{tot}$	3.2	4.4	4.4	4.4	4.4	4.3	4.2	%

OPERATING CHARACTERISTICS (continued)

Phase inverter Fig. 4 see page 9

Anode supply voltage	$V_{ba}$	250	350	V		
Anode voltage	$V_a$	65	90	V		
Cathode resistor	$R_k$	68	82	$k\Omega$		
Anode resistor	$R_a, R_{a'}$	100	150	$k\Omega$		
Anode current	$I_a + I_{a'}$	1.0	1.2	mA		
Voltage gain	$V_o/V_i$	25		27		
Output voltage ( $+I_g = 0.3 \mu A$ )	$V_o$	7	20	10	35	$V_{RMS}$
Total distortion <sup>1)</sup>	$d_{tot}$	0.6	1.8	0.5	1.8	%

$V_a$  should be adjusted to the specified value of  $I_a + I_{a'}$

Phase inverter Fig. 5 see page 9

Anode supply voltage	$V_{ba}$	250	350	V		
Cathode resistor	$R_k$	1200	820	$\Omega$		
Anode current	$I_a + I_{a'}$	1.08	1.7	mA		
Voltage gain	$V_o/V_i$	58		62		
Output voltage ( $+I_g = 0.3 \mu A$ )	$V_o$	7.0	35	9	45	$V_{RMS}$
Total distortion <sup>1)</sup>	$d_{tot}$	1.1	5.5	0.7	3.5	%

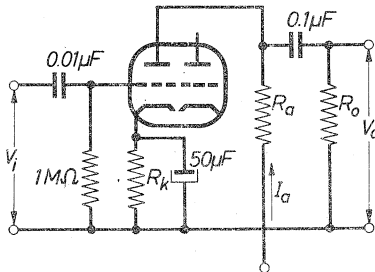

Fig. 1

<sup>1)</sup> The distortion is about proportional to the output voltage.

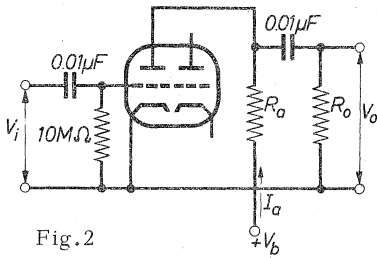

Fig. 2

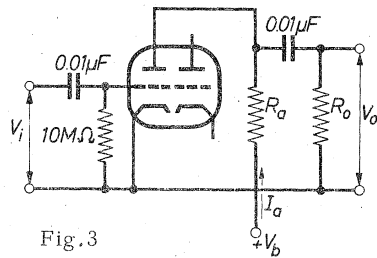

Fig. 3

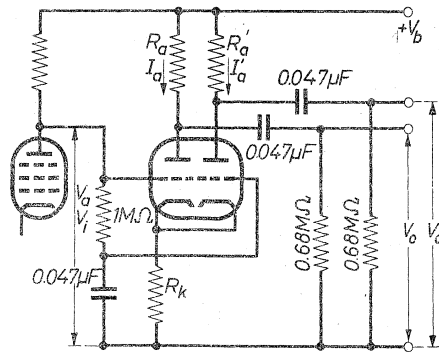

Fig. 4

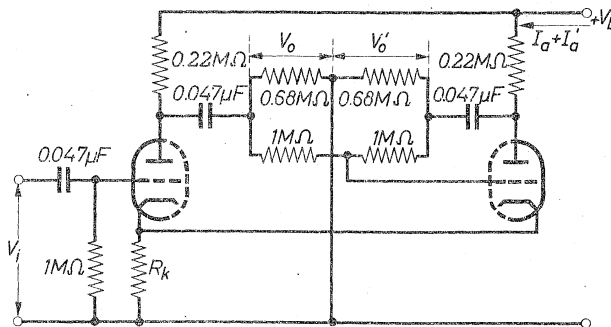
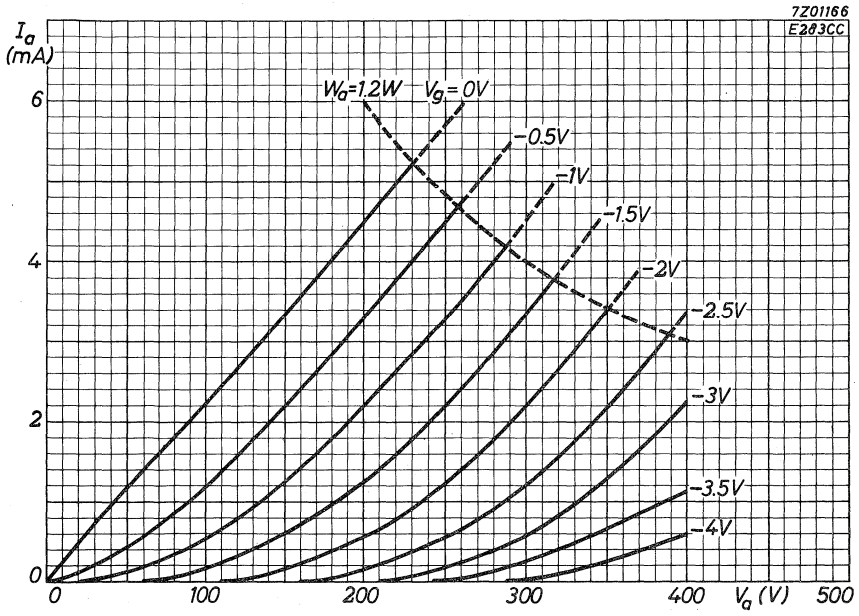

Fig. 5



## S.Q. TUBE

Special quality double triode designed for use in cascode circuits and as R.F. or I.F. amplifier.

### QUICK REFERENCE DATA

Life test	10 000 hours	
Low interface resistance		
Mechanical quality	Shock and vibration resistant	
Base	Noval. Gold plated pins	
Heating	Indirect A.C. or D.C.; parallel supply	
Heater voltage	$V_f$	6.3 V
Heater current	$I_f$	475 mA
Anode current	$I_a$	30 mA
Mutual conductance	$S$	20 mA/V
Equivalent noise resistance (R.F.)	$R_{eq}$	200 $\Omega$
Noise figure	$F$	5.7 dB

### DIMENSIONS AND CONNECTIONS

Dimensions in mm

Base: Noval

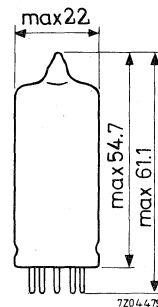
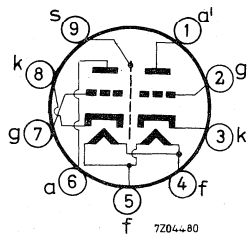

## CHARACTERISTICS

Column I Nominal value or setting of the tube

II Range values for equipment design: Initial spread

III Range values for equipment design: End of life

		I	II	III	
Heater voltage	$V_f$	6.3			V
Heater current	$I_f$	475	450 - 500		mA
Anode supply voltage	$V_{ba}$	100			V
Grid supply voltage	$+V_{bg}$	9			V
Cathode resistor	$R_k$	350			$\Omega$
Anode current	$I_a$	30	28 - 32	min. 26.5	mA
Mutual conductance	S	20	17 - 22.5	min. 14.5	mA/V
Amplification factor	$\mu$	25			
Internal resistance	$R_i$	1.25			k $\Omega$
Equivalent noise resistance	$R_{eq}$	200			$\Omega$
Noise figure in cascode circuit	F	5.7			dB
Adapted to minimum noise					
Negative grid current	$-I_g$		max. 0.2	max. 1	$\mu A$
Anode supply voltage	$V_{ba}$	60			V
Cathode resistor	$R_k$	80			$\Omega$
Anode current	$I_a$	1.5			mA
Mutual conductance	S	15.5			mA/V
Amplification factor	$\mu$	25			
Internal resistance	$R_i$	1.85			k $\Omega$
Noise figure in cascode circuit	F	5			dB
Adapted to minimum noise					



**CAPACITANCES** Each system if applicable

Grid to cathode heater and screen	$C_{g/kfs}$	4.7 pF
Anode to cathode heater and screen	$C_{a/kfs}$	1.9 pF
	$C_{a'/k'fs}$	1.8 pF
Anode to grid	$C_{ag}$	1.8 pF
Cathode to grid heater and screen	$C_{k/gfs}$	7.8 pF
Anode to grid heater and screen	$C_{a/gfs}$	3.5 pF
	$C_{a'/gfs}$	3.4 pF
Anode to cathode	$C_{ak}$	0.25 pF
Anode to anode other section	$C_{aa'}$	max. 0.05 pF
Grid to grid other section	$C_{gg'}$	max. 0.005 pF

**SHOCK AND VIBRATION RESISTANCE**

The following test conditions are applied to assess the mechanical quality of the tube. These conditions are not intended to be used as normal operating conditions.

Shock

The tube is subjected 5 times in each of 4 positions to an acceleration of 500 g supplied by an NRL shock machine with the hammer lifted over an angle of 30°.

Vibration

The tube is subjected during 32 hours in each of 3 positions to a vibration frequency of 50 Hz with an acceleration of 2.5 g.

**LIFE**

Production samples are tested during 10 000 hours.

## LIMITING VALUES (Absolute max. rating system)

Anode voltage	$V_{a0}$	max. 400 V
	$V_a$	max. 250 V
Anode dissipation	$W_a$	max. 3 W
Grid voltage	$-V_g$	max. 50 V
Grid peak voltage	$-V_{gp}$	max. 150 V
Max. pulse duration		10 $\mu$ sec
Max. duty factor		0.01
Grid resistor with automatic bias	$R_g$	max. 1 M $\Omega$
Cathode current	$I_k$	max. 40 mA
Cathode peak current	$I_{kp}$	max. 400 mA
Max. pulse duration		10 $\mu$ sec
Max. duty factor		0.01
Voltage between cathode and heater	$V_{kf}$	max. 150 V
Bulb temperature	$t_{bulb}$	max. 190 $^{\circ}$ C

Heater voltage: The average heater voltage should be 6.3 V.

Variations of the heater voltage exceeding the range of 6.0 V to 6.6 V will shorten the tube life.

The tolerance of heater current (column II) should be taken into account.

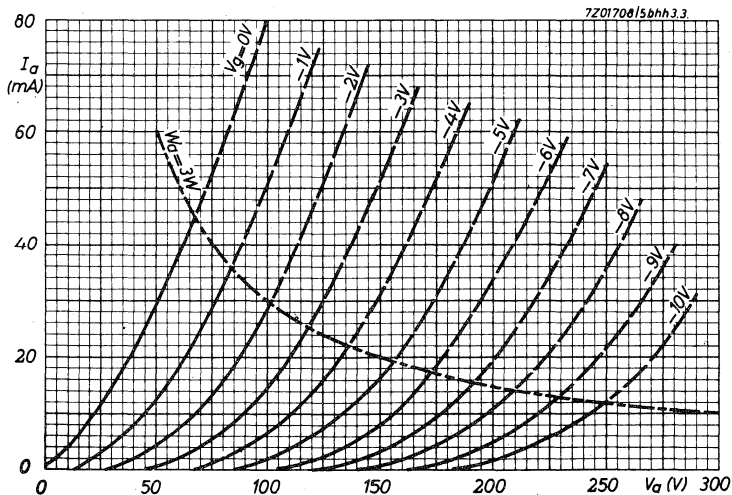

## S.Q. TUBE

Special quality pentode designed for use as wide band amplifier.

### QUICK REFERENCE DATA

Life test	10 000 hours	
Low interface resistance		
Mechanical quality	Shock and vibration resistant	
Base	Noval. Gold plated pins	
Heating	Indirect A.C. or D.C.; Parallel supply	
Heater voltage	$V_f$	6.3 V
Heater current	$I_f$	340 mA
Anode current	$I_a$	35 mA
Mutual conductance	$S$	50 mA/V
Equivalent noise resistance	$R_{eq}$	110 $\Omega$
Quality factor	$\frac{S}{2\pi(C_{g1} + C_a + 5)}$	250 MHz

### DIMENSIONS AND CONNECTIONS

Dimensions in mm

Base: Noval

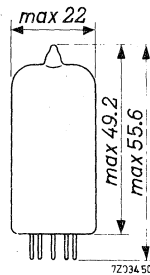
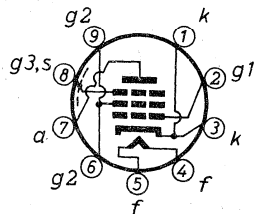

## CHARACTERISTICS

Column I Nominal value or setting of the tube

II Range values for equipment design: Initial spread

III Range values for equipment design: End of life

		I	II	III	
Heater voltage	$V_f$	6.3			V
Heater current	$I_f$	340	320 - 360		mA
Anode supply voltage	$V_{ba}$	135			V
Grid No.3 voltage	$V_{g3}$	0			V
Grid No.2 supply voltage	$V_{bg2}$	165			V
Grid No.1 supply voltage	$+V_{bg1}$	12.5			V
Cathode resistor	$R_k$	360			$\Omega$
Anode current	$I_a$	35	(negligible spread)		mA
Grid No.2 current	$I_{g2}$	5.0	4.4 - 5.6		mA
Mutual conductance	S	50	42 - 58	min. 35	mA/V
Internal resistance	$R_i$	42			k $\Omega$
Amplification factor of grid No.2 to grid No.1	$\mu_{g2g1}$	57			
Negative grid current	$-I_{g1}$		max. 0.1	max. 0.2	$\mu A$
Equivalent noise resistance Frequency = 45 MHz	$R_{eq}$	110			$\Omega$
Input resistance Frequency = 100 MHz	$r_{g1}$	415			$\Omega$
Quality factor $\frac{S}{2\pi(C_{g1}+C_a+5)}$					
a) without shield		250			MHz
b) with shield		245			MHz
Anode supply voltage	$V_{ba}$	120			V
Grid No.3 voltage	$V_{g3}$	0			V
Grid No 2 supply voltage	$V_{bg3}$	150			V
Cathode resistor	$R_k$	47			$\Omega$
Anode current	$I_a$	35	31 - 39		mA

**CHARACTERISTICS (continued)**

Hum voltage

Grid No.1 resistor  $R_{g_1} = 0.5 \text{ M}\Omega$   
 Midtap heater transformer grounded  
 Cathode resistor decoupled

Leakage current between cathode and heater

Voltage between cathode and heater  $V_{kf} = 100 \text{ V}$

Insulation resistance between anode and other electrodes

Measured with  $V = 250 \text{ V}$

	II	III	
$V_{g_1}$	max. 150		$\mu\text{V}$
$I_{kf}$	max. 10	max. 20	$\mu\text{A}$
R	min. 100	min. 40	$\text{M}\Omega$

**CAPACITANCES**

		Without external shield		With external shield		
		I	II	I	II	
Anode to grid No.3, grid No.2, cathode, heater and screen	$C_{a/g_3g_2kfs}$	3.5	3.2-3.8	4.1	3.9-4.3	pF
Grid No.1 to grid No.3, grid No.2, cathode, heater and screen						
( $I_k = 0 \text{ mA}$ )	$C_{g_1/g_3g_2kfs}$	14.5	13- 16	14.5	13- 16	pF
( $I_k = 40 \text{ mA}; f = 100 \text{ Mc/s}$ )	$C_{g_1/g_3g_3kfs}$	24	22- 26	24	22- 26	pF
Anode to grid No.1	$C_{ag_1}$		max. 36		max. 32	mpF
Anode to cathode	$C_{ak}$	60	53- 67	33	26- 40	mpF
Anode to heater	$C_{af}$	31	26- 36	20	12- 28	mpF
Grid No.1 to heater	$C_{g_1f}$	60	40- 80	55	35- 75	mpF
Cathode to heater	$C_{kf}$			5.2	4.2-6.2	pF

**SHOCK AND VIBRATION RESISTANCE**

The following test conditions are applied to assess the mechanical quality of the tube. These conditions are not intended to be used as normal operating conditions.

Shock

The tube is subjected 5 times in each of 4 positions to an acceleration of 500 g supplied by an NRL shock machine with the hammer lifted over an angle of 30°.

Vibration

The tube is subjected during 32 hours in each of 3 positions to a vibration frequency of 50 Hz with an acceleration of 2.5 g.

**LIFE**

Production samples are tested to be within the end of life values (column III) under the following conditions during 10 000 hours.

Anode supply voltage	$V_{ba}$	165 V
Anode resistor	$R_a$	820 $\Omega$
Grid No.3 voltage	$V_{g3}$	0 V
Grid No.2 supply voltage	$V_{bg2}$	165 V
Grid No.1 supply voltage	$+V_{bg1}$	12.5 V
Cathode resistor	$R_k$	360 $\Omega$
Anode current	$I_a$	35 mA
Voltage between cathode and heater	$V_{kf}$	100 V

**LIMITING VALUES** (Absolute max. rating system)

Anode voltage	$V_{a0}$	max. 400 V
	$V_a$	max. 250 V
Anode dissipation	$W_a$	max. 5 W
Grid No.2 voltage	$V_{g20}$	max. 400 V
	$V_{g2}$	max. 200 V
Grid No.2 dissipation	$W_{g2}$	max. 1 W <sup>1)</sup>
Grid No.1 voltage	$-V_{g1}$	max. 25 V
Grid No.1 peak voltage	$-V_{g1p}$	max. 50 V
	$+V_{g1p}$	max. 50 V
Grid No.1 dissipation	$W_{g1}$	max. 10 mW

Maximum averaging time = 1 s

1) Care should be taken not to exceed the rated  $W_{g2}$  value due to switching of positive supply voltages.

## LIMITING VALUES (Absolute max. rating system) (continued)

Grid No.1 resistor

With fixed bias	$R_{g1}$	max.	0.2	$M\Omega$
With automatic bias $R_k = 47 \Omega$	$R_{g1}$	max.	0.6	$M\Omega$
$R_k = 360 \Omega$	$R_{g1}$	max.	3.5	$M\Omega$

Cathode current

 $I_k$  max. 50 mA

Cathode current

 $I_k$  max. 65 mA

(Life expectancy 1000 hours)

Voltage between cathode and heater

 $V_{kf}$  max. 100 V

Bulb temperature

 $t_{bulb}$  max. 200 °C

Bulb temperature

 $t_{bulb}$  max. 220 °C

(Life expectancy 1000 hours)

Heater voltage: The average heater voltage should be 6.3 V.

Variations of the heater voltage exceeding the range of 6.0 V to 6.6 V will shorten the tube life.

The tolerance of heater current (column II) should be taken into account.

## OPERATING CHARACTERISTICS

Output tube class A

Anode supply voltage	$V_{ba}$	155	V
Grid No.3 voltage	$V_{g3}$	0	V
Grid No.2 supply voltage	$V_{bg2}$	165	V
Grid No.1 supply voltage	$+V_{bg1}$	12.5	V
Cathode resistor	$R_k$	360	$\Omega$
Cathode capacitor	$C_k$	1000	$\mu F$
Anode resistor	$R_{a\sim}$	560	$\Omega$
Anode current	$I_a$	35	mA
Anode current, peak to peak	$I_{ap}$	40	mA
Total distortion	$d_{tot}$	7.5	%

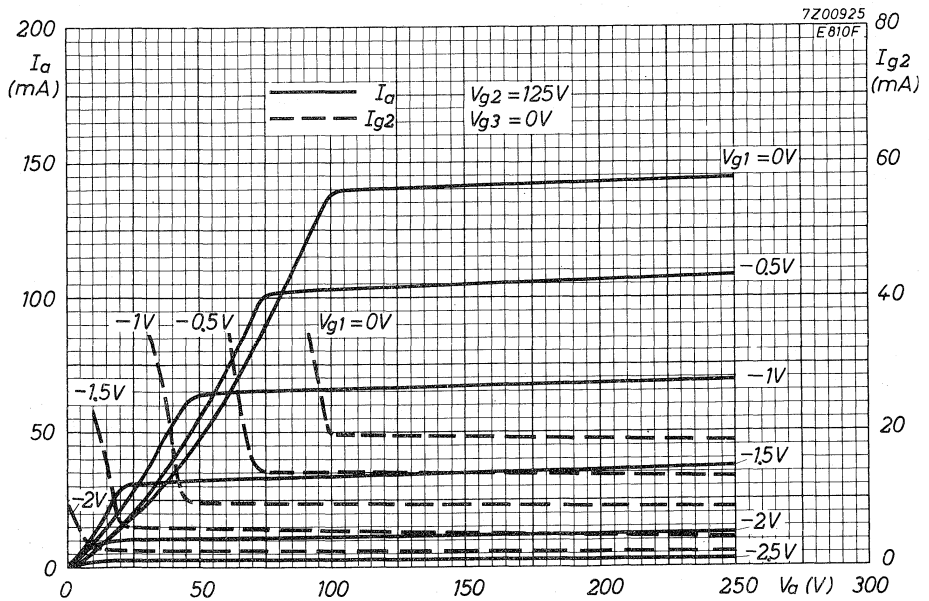
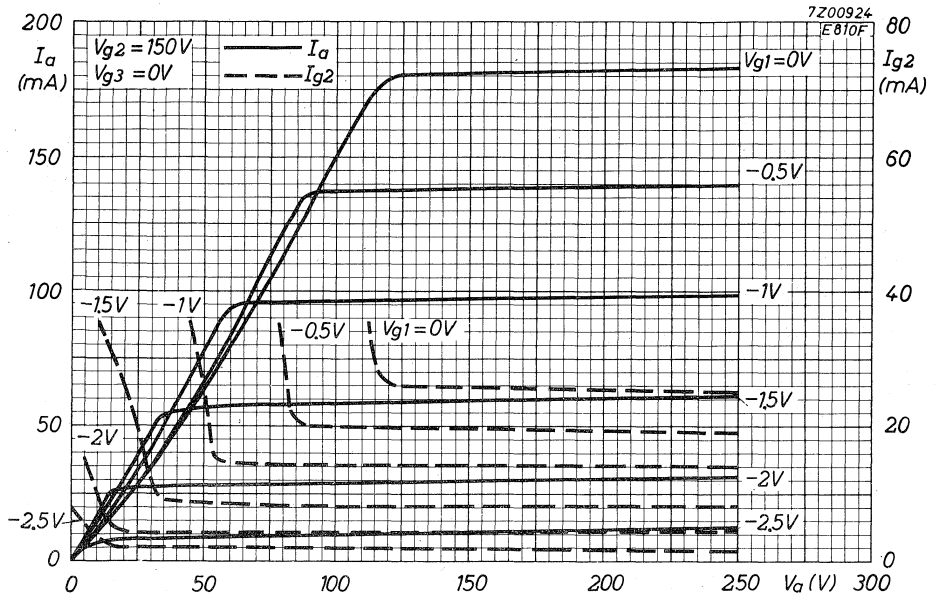



## S.Q. TUBE

Triode designed for use as grounded grid U.H.F. amplifier for frequencies up to 500 MHz.

### QUICK REFERENCE DATA

Life test	500 hours	
Base	Noval. Gold plated pins	
Heating	Indirect A.C. or D.C.; parallel supply	
Heater voltage	$V_f$	6.3 V
Heater current	$I_f$	430 mA
Mutual conductance	S	12 mA/V

### DIMENSIONS AND CONNECTIONS

Dimensions in mm

Base: Noval

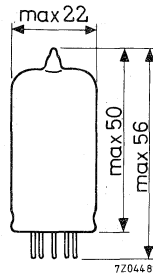
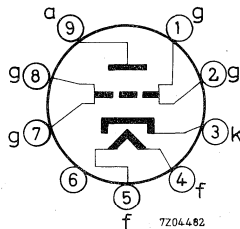

**CHARACTERISTICS**

Anode voltage	$V_a$	250 V
Grid voltage	$-V_g$	1.5 V
Anode current	$I_a$	15 mA
Mutual conductance	$S$	12 mA/V
Amplification factor	$\mu$	80

**CAPACITANCES**

Grid and pin No.6 to cathode and heater	$C_{gp6/kf}$	5.1 pF
Grid, heater and pin No.6 to cathode	$C_{gfp6/k}$	9.3 pF
Anode to cathode	$C_{ak}$	max. 0.075 pF
Anode to cathode and heater	$C_{a/kf}$	max. 0.08 pF
Anode to grid and pin No.6	$C_{a/gp6}$	3.4 pF
Anode to grid, heater and pin No.6	$C_{a/gfp6}$	3.4 pF
Cathode to heater	$C_{kf}$	max. 8 pF

**LIFE**

Production samples are tested during 500 hours.

**LIMITING VALUES** (Design centre rating system)

Anode voltage	$V_{a0}$	max. 550 V
	$V_a$	max. 300 V
Anode dissipation	$W_a$	max. 4 W
Cathode current	$I_k$	max. 15 mA
Voltage between cathode and heater	$V_{kf}$	max. 100 V
Grid resistor	$R_g$	max. 0.3 M $\Omega$

7Z04484-53.hj

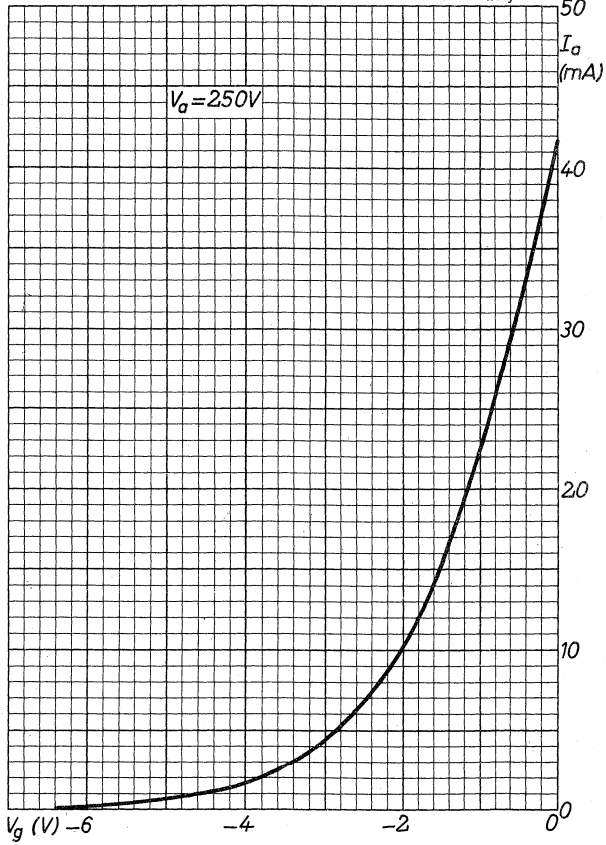

# EC80

7Z04483-5.3.hj

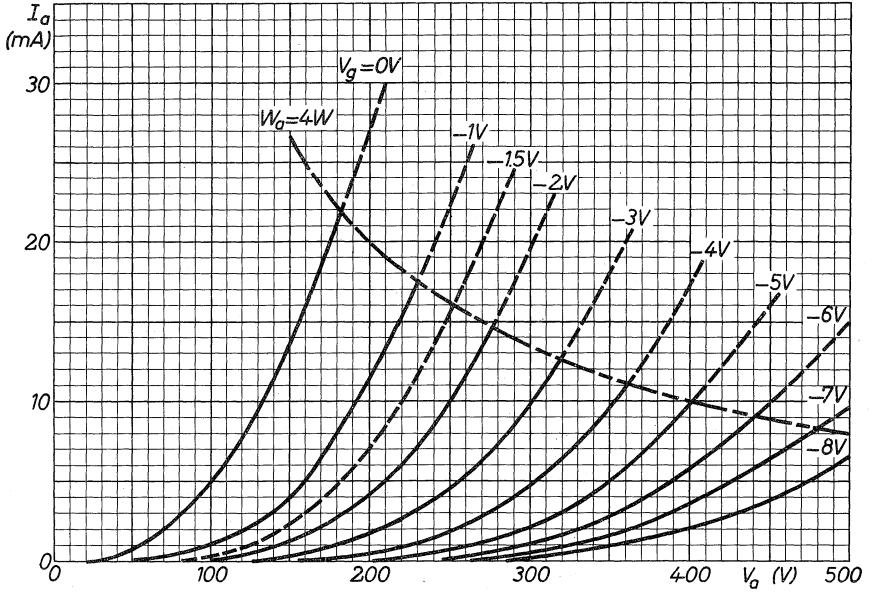

7Z04485-5.3.hj

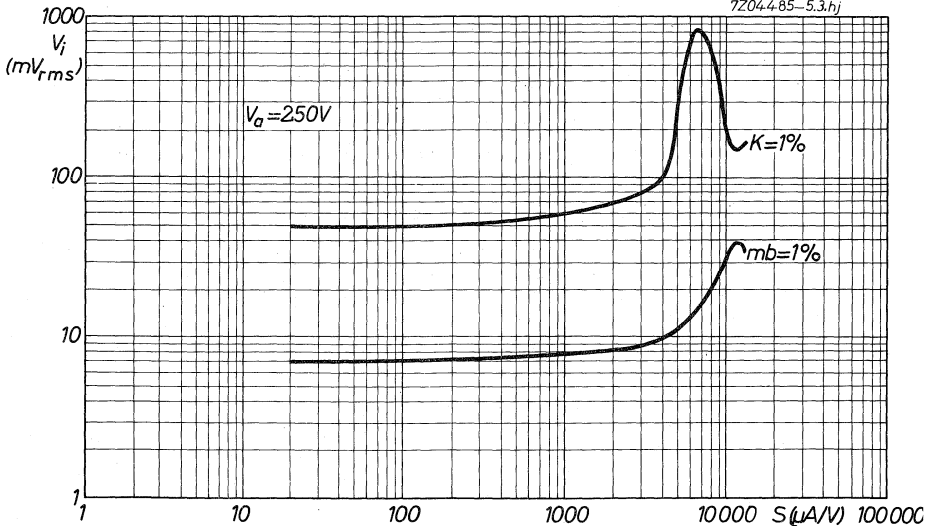

## S.Q. TUBE

U.H.F. oscillator triode for frequencies up to 750 MHz.

QUICK REFERENCE DATA		
Base	Noval. Gold plated pins	
Heating	Indirect A.C. or D.C.; parallel supply	
Heater voltage	$V_f$	6.3 V
Heater current	$I_f$	175 mA
Anode current	$I_a$	30 mA
Mutual conductance	S	5.5 mA/V

### DIMENSIONS AND CONNECTIONS

Dimensions in mm

Base: Noval

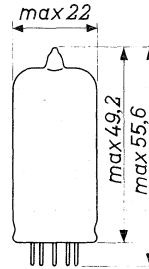
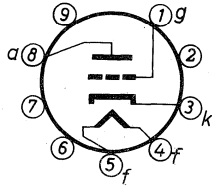

### CAPACITANCES

Grid to all except anode	$C_{g(a)}$	1.8 pF
Anode to all except grid	$C_{a(g)}$	0.7 pF
Anode to grid	$C_{ag}$	1.6 pF
Grid to heater	$C_{gf}$	max. 0.25 pF
Cathode to heater	$C_{kf}$	2.3 pF

### CHARACTERISTICS

Heater voltage	$V_f$	6.3	V
Heater current	$I_f$	175	mA
Anode voltage	$V_a$	120	150 V
Grid voltage	$-V_g$	2	2 V
Anode current	$I_a$	20	30 mA
Mutual conductance	S	4	5.5 mA/V
Amplification factor	$\mu$	16	16

OPERATING CHARACTERISTICS AND LIMITING VALUES

Operation as U.H.F. oscillator

A) Heater supply voltage	$V_f$	6.3	V
Series resistor in heater circuit	R	3	$\Omega$
Wave length	$\lambda$	40      80	cm
Anode voltage	$V_a$	220      275	V
Anode current	$I_a$	18.6      17.2	mA
Grid current	$+I_g$	1.5      2.8	mA
Output power	$W_o$	0.6      2.1	W

LIMITING VALUES Design centre rating system

Anode voltage	$V_{a0}$	max. 550	V
Anode voltage	$V_a$	max. 275	V
Anode dissipation	$W_a$	max. 3.5	W
Cathode current	$I_k$	max. 20	mA
Grid current	$I_g$	max. 7.5	mA
Negative grid voltage	$-V_g$	max. 100	V
Voltage between cathode and heater	$V_{kf}$	max. 100	V
Grid resistor	$R_g$	max. 1	M $\Omega$

B) Heater supply voltage	$V_f$	6.3	V
Series resistor in heater circuit	R	3	$\Omega$
Wave length	$\lambda$	40      80	cm
Anode voltage	$V_a$	290      300	V
Anode current	$I_a$	19.6      18.6	mA
Grid current	$+I_g$	0.4      1.5	mA
Output power	$W_o$	0.7      2.2	W

With these operating conditions the following limiting values should be strictly adhered to

LIMITING VALUES Design centre rating system unless otherwise specified.

Anode voltage	$V_{a_0}$	max.	550 V
Anode voltage (stabilized $\pm 1\%$ )	$V_a$	max.	300 V
Anode dissipation (Abs.max.)	$W_a$	max.	5 W
Cathode current	$I_k$	max.	20 mA
Grid current	$I_g$	max.	7.5 mA
Negative grid voltage	$-V_g$	max.	100 V
Voltage between cathode and heater	$V_{kf}$	max.	100 V
Grid resistor	$R_g$	max.	1 M $\Omega$

C) Heater voltage	$V_f$	6.3		V
Wave length	$\lambda$	40	80	cm
Anode voltage	$V_a$	220	300	V
Anode current	$I_a$	27.7	26.3	mA
Grid current	$I_g$	2.3	4	mA
Output power	$W_o$	1.1	3.8	W

LIMITING VALUES Design centre rating system unless otherwise specified.

Anode voltage	$V_{a_0}$	max.	550 V
Anode voltage (stabilized $\pm 1\%$ )	$V_a$	max.	300 V
Anode dissipation (Abs.max.)	$W_a$	max.	5 W
Cathode current (Abs.max.)	$I_k$	max.	30 mA
Grid current	$+I_g$	max.	7.5 mA
Grid voltage	$-V_g$	max.	100 V
Voltage between cathode and heater	$V_{kf}$	max.	100 V
Grid resistor	$R_g$	max.	1 M $\Omega$

Heater voltage: The average heater voltage should be 6.3 V  
 Variation of the heater voltage should not exceed the range  
 the range of 6.3 V  $\pm 3\%$ .

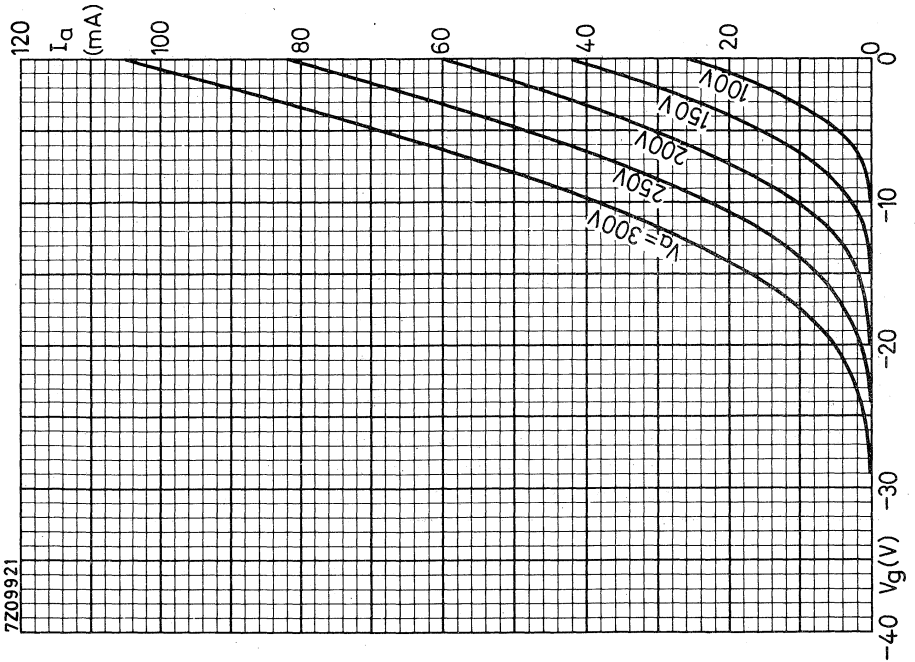
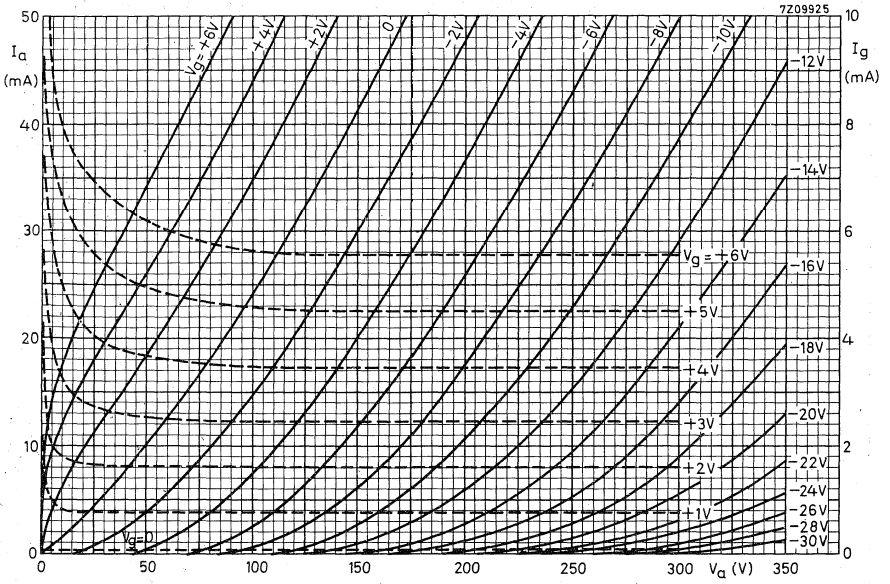



**S.Q. TUBE**

Triode designed for use as grounded grid U. H. F. amplifier for frequencies up to 250 MHz.

**QUICK REFERENCE DATA**

Life test	500 hours
Base	Miniature 7-pin
Heating	Indirect A. C. or D. C. Series or parallel supply
Heater voltage	$V_f$ 6.3 V
Heater current	$I_f$ 300 mA
Mutual conductance	S 8.5 mA/V

**DIMENSIONS AND CONNECTIONS**

Dimensions in mm

Base: Miniature 7-pin

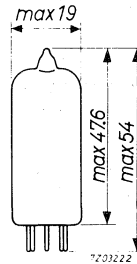
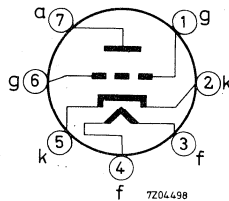

**CHARACTERISTICS**

Anode voltage	$V_a$	250 V
Grid voltage	$-V_g$	1.5 V
Cathode resistor	$R_k$	150 $\Omega$
Anode current	$I_a$	10 mA
Mutual conductance	$S$	8.5 mA/V
Amplification factor	$\mu$	100
Internal resistance	$R_i$	12 k $\Omega$
Equivalent noise resistance	$R_{eq}$	400 $\Omega$

**CAPACITANCES**

Grid to cathode and heater	$C_{g/kf}$	8.5 pF
Anode to cathode and heater	$C_{a/kf}$	max. 0.2 pF
Anode to grid	$C_{ag}$	2.5 pF

**LIFE**

Production samples are tested during 500 hours.

**LIMITING VALUES** (Absolute max. rating system)

Anode voltage	$V_{a0}$	max. 550 V
	$V_a$	max. 250 V
Cathode current	$I_k$	max. 15 mA
Grid voltage	$-V_g$	max. 100 V
Voltage between cathode and heater	$V_{kf}$	max. 150 V
Anode dissipation	$W_a$	max. 2.5 W

## S.Q. TUBE

Special quality triode, designed for use as amplifier in measuring probes.

QUICK REFERENCE DATA	
Life test	1000 hours
Envelope	Subminiature
Low interface resistance	
Mechanical quality	Shock and vibration resistant
Heating	Indirect A. C. or D. C.; parallel supply
Heater voltage	$V_f$ 6.3 V
Heater current	$I_f$ 185 mA
Equivalent grid noise voltage	$V_n$ max. 1 mV
Anode current	$I_a$ 14 mA
Mutual conductance	$S$ 14.5 mA/V

### DIMENSIONS AND CONNECTIONS

Dimensions in mm

Envelope: Subminiature

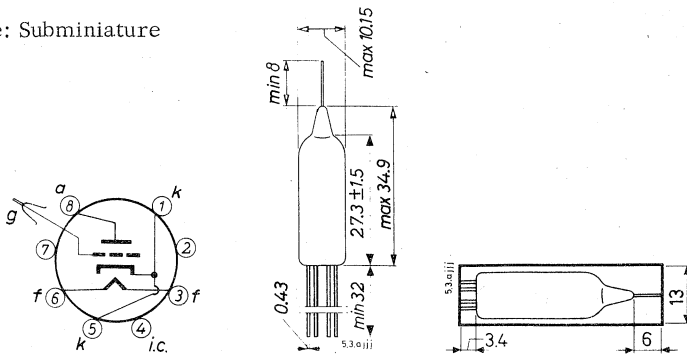

Leads should not be soldered nearer than 5 mm to the seal.

Leads should not be bent nearer than 2 mm to the seal.

Method of shielding. See fig. 1.

CHARACTERISTICS

Column I Nominal value or setting of the tube

II Range values for equipment design: Initial spread

III Range values for equipment design: End of life

		I	II	III	
Heater voltage	$V_f$	6.3			V
Heater current	$I_f$	185	175- 195		mA
Anode voltage	$V_a$	80			V
Grid voltage	$-V_g$	2			V
Anode current	$I_a$	14			mA
Mutual conductance	S	14.5			mA/V
Amplification factor	$\mu$	27.5			
Input resistance	$r_g$	300			$\Omega$
Frequency = 250 MHz					
Input resonance frequency	f	400			MHz
Anode supply voltage	$V_{ba}$	82			V
Cathode resistor	$R_k$	143			$\Omega$
Anode current	$I_a$	14.0	11.2-16.8	min. 8.2	mA
Mutual conductance	S	14.5			mA/V
Anode supply voltage	$V_{ba}$	90			V
Cathode resistor	$R_k$	680			$\Omega$
Grid supply voltage	$+V_{bg}$	7.5			V
Anode current	$I_a$	14			mA
Mutual conductance	S	14.5	12.9-16.1	min. 9.2	mA/V
<u>Negative grid current</u>	$-I_g$		max. 0.01	max. 0.01	$\mu A$
<u>Leakage current between cathode and heater</u>	$I_{kf}$		max. 5	max. 10	$\mu A$

Voltage between cathode and heater = 55 V. Cath. positive

**CHARACTERISTICS (continued)**

Equivalent grid microphony voltage

Peak acceleration = 4 g

Frequency = 50 Hz

	I	II	
$V_g$		max. 1.0	mV <sub>RMS</sub>

Equivalent grid hum voltage

Grid resistor = 0.5 MΩ

Cathode resistor = 100 Ω

Heater centre grounded

$V_g$		max. 1.0	mV <sub>RMS</sub>
-------	--	----------	-------------------

**CAPACITANCES**

Grid to cathode

$C_{gk}$	3.5	2.9 - 4.1	pF
----------	-----	-----------	----

Anode to grid

$C_{ag}$	1.7	1.4 - 2.0	pF
----------	-----	-----------	----

Grid to heater

$C_{gf}$	33	23 - 43	mpF
----------	----	---------	-----

Anode to cathode

$C_{ak}$	450	325 - 575	mpF
----------	-----	-----------	-----

Anode to heater

$C_{af}$	270	185 - 355	mpF
----------	-----	-----------	-----

**SHOCK AND VIBRATION RESISTANCE**

The following test conditions are applied to assess the mechanical quality of the tube. These conditions are not intended to be used as normal operating conditions.

Shock

The tube is subjected 5 times in each of 4 positions to an acceleration of 500 g supplied by an NRL shock machine with the hammer lifted over an angle of 30°.

Vibration

The tube is subjected during 32 hours in each of 3 positions to a vibration frequency of 50 Hz with an acceleration of 2.5 g.

**LIFE**

Production samples are tested to be within the end of life values during 1000 hours.

**LIMITING VALUES** (Absolute max. rating system)

Anode voltage	$V_{a0}$	max.	275 V
	$V_a$	max.	110 V
Anode dissipation	$W_a$	max.	1.5 W
Grid voltage	$-V_g$	max.	55 V
Cathode current	$I_k$	max.	22 mA
Voltage between cathode and heater	$V_{kf}$	max.	55 V
Bulb temperature	$t_{bulb}$	max.	170 °C

Grid resistor: The grid resistance should be restricted to a value such that no limiting values are exceeded at  $-I_g = 0.01 \mu A$ .

The D.C. feed back factor of the operating circuit may be taken into account.

The  $R_g$  value will also be limited by the required current stability and the permissible hum level.

Heater voltage: The average heater voltage should be 6.3 V.

Variations of the heater voltage exceeding the range of 6.0 V to 6.6 V will shorten the tube life.

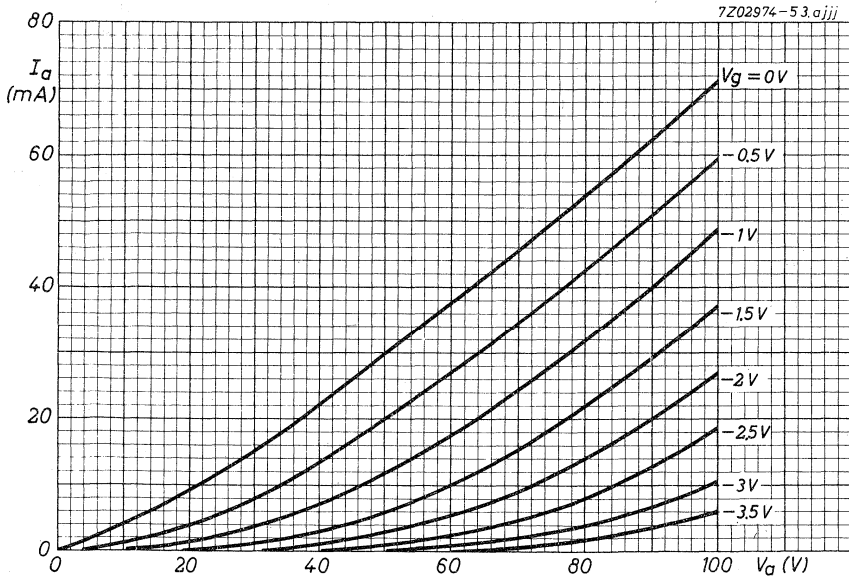

**S.Q. TUBE**

Special quality U.H.F. triode designed for use as R.F. amplifier and oscillator (max. frequency 1000 MHz).

**QUICK REFERENCE DATA**

Life test	10 000 hours	
Low interface resistance		
Mechanical quality	Shock and vibration resistant	
Base	Noval	
Heating	Indirect A.C. or D.C.; parallel supply	
Heater voltage	$V_f$	6.3 V
Heater current	$I_f$	280 mA
Anode current	$I_a$	25 mA
Mutual conductance	S	28 mA/V

**DIMENSIONS AND CONNECTIONS**

Dimensions in mm

Base: Noval

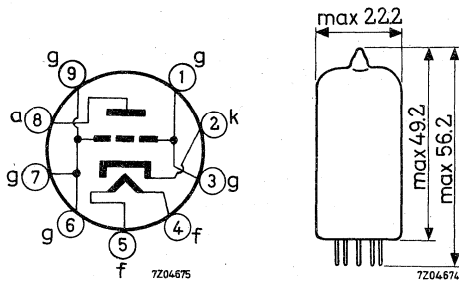

**CHARACTERISTICS**

Anode supply voltage	$V_{ba}$	200 V
Anode resistor	$R_a$	2.4 k $\Omega$
Cathode resistor	$R_k$	47 $\Omega$
Anode current	$I_a$	25 mA
Mutual conductance	S	28 mA/V
Amplification factor	$\mu$	60

**CAPACITANCES**

Without shield

Anode to cathode and heater	$C_{a/kf}$	0.1 pF
Grid to cathode and heater	$C_{g/kf}$	7 pF
Anode to grid	$C_{ag}$	1.4 pF

With external shield

Anode to cathode and heater	$C_{a/kf}$	0.09 pF
Grid and screen to cathode and heater	$C_{gs/kf}$	7.5 pF
Anode to grid and shield	$C_{a/gs}$	1.9 pF

**SHOCK AND VIBRATION RESISTANCE**

The following test conditions are applied to assess the mechanical quality of the tube. These conditions are not intended to be used as normal operating conditions.

Shock

The tube is subjected 5 times in each of 4 positions to an acceleration of 500 g supplied by an NRL shock machine with the hammer lifted over an angle of 30°.

Vibration

The tube is subjected during 32 hours in each of 3 positions to a vibration frequency of 50 Hz with an acceleration of 2.5 g.



**LIMITING VALUES** (Absolute max. rating system)

Anode voltage	$V_{a0}$	max. 400 V
	$V_a$	max. 200 V
Anode dissipation	$W_a$	max. 4.5 W
Grid voltage	$-V_g$	max. 20 V
Cathode current	$I_k$	max. 35 mA
Grid resistor	$R_g$	max. 500 k $\Omega$
Voltage between cathode and heater	$V_{kf}$	max. 100 V

Heater voltage: The average heater voltage should be 6.3 V.

Variations of the heater voltage exceeding the range of 6.0 V to 6.6 V will shorten the tube life.

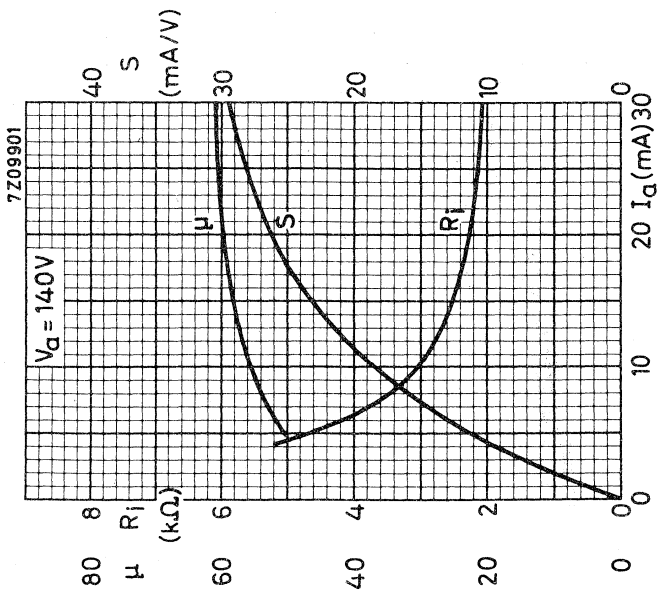
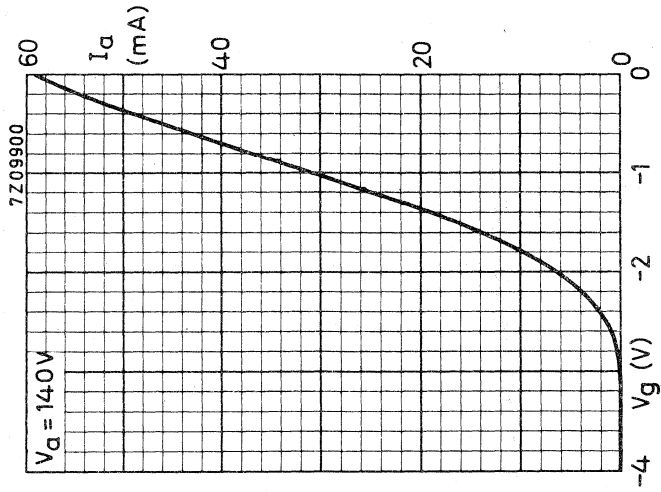

**S.Q. TUBE**

Special quality double triode with neutralisation screen, designed for use as V.H.F. amplifier (max. freq. 300 MHz) in a cascode circuit without external neutralisation, e.g. aerial amplifier for band III and frequency multiplier.

**QUICK REFERENCE DATA**

Life test	10 000 hours			
Low interface resistance				
Mechanical quality	Shock and vibration resistant			
Base	10 pin miniature with gold plated pins			
Heating	Indirect A.C. or D.C.; parallel supply			
Heater voltage	$V_f$	6.3	V	
Heater current	$I_f$	335	mA	
	Input section		Output section	
Anode voltage	90	90	90	90 V
Anode current	15	27	15	27 mA
Mutual conductance	13	17.5	17	22 mA/V

**DIMENSIONS AND CONNECTIONS**

Dimensions in mm

Base: 10 pin miniature

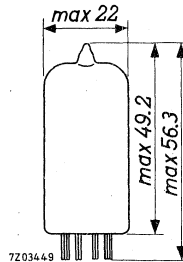
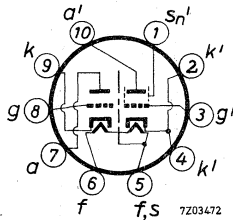

**CHARACTERISTICS**

Heater voltage	$V_f$	6.3		V
Heater current	$I_f$	335		mA
<u>Input section (unit a', g', k')</u>				
Anode voltage	$V_{a'}$	90	90	V
Neutralization screen voltage	$V_{Sn'}$	0	0	V
Grid voltage	$-V_{g'}$	2.1	1.4	V
Anode current	$I_{a'}$	15	27	mA
Mutual conductance	S	13	17.5	mA/V
Amplification factor	$\mu$	27	27	
Equivalent noise resistance	$R_{eq}$	250	200	$\Omega$
<u>Output section (unit a, g, k)</u>				
Anode voltage	$V_a$	90	90	V
Grid voltage	$-V_g$	2.0	1.4	V
Anode current	$I_a$	15	27	mA
Mutual conductance	S	17	22	mA/V
Amplification factor	$\mu$	28	28	
Equivalent noise resistance	$R_{eq}$	200	150	$\Omega$

<u>Insulation resistance between electrodes</u>	$R_{ins}$	Initial	min.	100	$M\Omega$
		End of life	min.	20	$M\Omega$

Leakage current between cathode and heater

Voltage between cathode and heater V = 150 V

Cathode positive	$I_{kf}$	Initial	max.	15	$\mu A$
		End of life	max.	20	$\mu A$

Voltage between cathode and heater V = 50 V

Cathode negative	$I_{kf}$	Initial	max.	15	$\mu A$
		End of life	max.	20	$\mu A$

**CAPACITANCES**Input system (unit a', g', k')

Grid to cathode, filament and neutralisation screen	$C_{g'/k'fsn'}$	5.1 pF
Anode to cathode, filament and neutralisation screen	$C_{a'/k'fsn'}$	5.0 pF
Grid to neutralisation screen	$C_{g'sn'}$	1.4 pF
Anode to grid	$C_{a'g'}$	0.45 pF
Anode to neutralisation screen	$C_{a'sn'}$	3.4 pF

Output system (unit a, g, k)

Cathode to grid and filament	$C_{k/gf}$	6.5 pF
Anode to grid and filament	$C_{a/gf}$	3.2 pF
Anode to cathode	$C_{ak}$	180 mpF
Anode to grid	$C_{ag}$	1.5 pF

**SHOCK AND VIBRATION RESISTANCE**

The following test conditions are applied to assess the mechanical quality of the tube. These conditions are not intended to be used as normal operating conditions.

Shock

The tube is subjected 5 times in each of 4 positions to an acceleration of 500 g supplied by an NRL shock machine with the hammer lifted over an angle of 30°.

Vibration

The tube is subjected during 32 hours in each of 3 positions to a vibration frequency of 50 Hz with an acceleration of 2.5 g.

**LIFE**

Production samples are tested under the following conditions during 10000 hours: (each unit)

Heater voltage	$V_f$	6.3 V
Anode supply voltage	$V_{ba}$	110 V
Grid supply voltage	$V_{bg}$	17 V
Cathode resistor	$R_k$	680 $\Omega$

## LIMITING VALUES (Absolute max. rating system)

(Each unit)

Anode voltage	$V_{a0}$	max. 450 V
	$V_a$	max. 250 V
Anode dissipation	$W_a$	max. 2.7 W
Grid voltage	$-V_g$	max. 50 V
Grid peak voltage	$-V_{gp}$	max. 150 V
Duty factor max. 1%		
Pulse duration max. 10 $\mu$ s		
Cathode current	$I_k$	max. 40 mA
Cathode peak current	$I_{kp}$	max. 400 mA
Duty factor max. 10%		
Pulse duration max. 200 $\mu$ s		
Grid resistor	$R_g$	max. 1 M $\Omega$
Automatic bias		
Voltage between cathode and heater		
Cathode positive	$V_{kf} (k+)$	max. 150 V
Cathode negative	$V_{kf} (k-)$	max. 50 V
Bulb temperature		max. 225 $^{\circ}$ C

OPERATING CHARACTERISTICS

Cascode circuit, Frequency 200 MHz

Supply voltage	$V_b$	200	200 V
Cathode resistor	$R_k'$	1200	680 $\Omega$
Anode current	$I_a$	15.5	26.5 mA
Input resistance	$r_{g'}$	910	670 $\Omega$
Input capacitance	$C_i$	11	12 pF
Noise figure	F	2.5	2.5 $kT_o$

Adapted to minimum noise

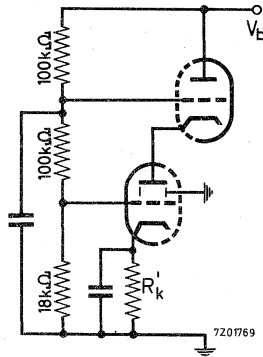





**S.Q. TUBE**

Special quality double triode designed for use as A.F. amplifier, oscillator and multivibrator.

**QUICK REFERENCE DATA**

Life test	1000 hours
Low interface resistance	
Mechanical quality	Shock and vibration resistant
Base	Noval
Heating	Indirect A.C. or D.C.; Parallel supply
Heater voltage	$V_f$ 6.3 or 12.6 V
Heater current	$I_f$ 300 or 150 mA
Anode current	$I_a$ 1.2 mA
Mutual conductance	S 1.6 mA/V
Amplification factor	$\mu$ 100

**DIMENSIONS AND CONNECTIONS**

Dimensions in mm

Base: Noval

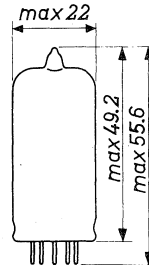
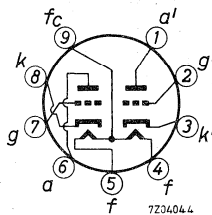

## CHARACTERISTICS Each system if applicable.

Column I Nominal value or setting of the tube

II Range values for equipment design: Initial spread

III Range values for equipment design: End of life

		I	II	III	
Heater voltage	$V_f$	6.3			V
Heater current	$I_f$	300	276- 324		mA
Anode voltage	$V_a$	250			V
Grid voltage	$-V_g$	2			V
Anode current	$I_a$	1.2	0.75-1.75		mA
Mutual conductance	S	1.6	1.25-2.05	min. 1.12	mA/V
Amplification factor	$\mu$	100			
Internal resistance	$R_i$	62.5			k $\Omega$
Difference in anode current of both systems	$ I_a - I_a' $		max. 0.6		mA
Negative grid current	$-I_g$		max. 0.5	max. 0.5	$\mu$ A
<u>Vibrational noise output</u> (units connected parallel)	$V_o$		max. 25		mVRMS
Anode supply voltage $V_{ba} = 250$ V					
Grid voltage $-V_g = 2$ V					
Frequency $f = 25$ Hz					
Acceleration 2.5 g					
Anode resistor $R_a = 2$ k $\Omega$					
<u>Amplification</u>					
Anode supply voltage	$V_{ba}$	100			V
Grid voltage	$V_g$	0			V
Anode resistor	$R_a$	0.5			M $\Omega$
Grid resistor	$R_g$	10			M $\Omega$
Input voltage	$V_i$	0.2			V <sub>RMS</sub>
Output voltage	$V_o$		min. 8.4		V <sub>RMS</sub>

**CHARACTERISTICS** (continued)

		I	II	III	
Anode voltage	$V_a$	100			V
Grid voltage	$-V_g$	1			V
Anode current	$I_a$	0.5			mA
Mutual conductance	S	1.25			mA/V
Amplification factor	$\mu$	100			
Internal resistance	$R_i$	80			k $\Omega$
<u>Insulation resistance between electrodes</u>	$R_{ins}$		min. 100	min. 50	M $\Omega$
Voltage between electrodes V = 100 V					
<u>Leakage current between cathode and heater</u>	$I_{kf}$		max. 10	max. 20	$\mu$ A
Voltage between cathode and heater $V_{kf} = 100$ V					

**CAPACITANCES.** Without external screen.  
Each system if applicable.

Anode to grid, cathode and heater	$C_{a/gkf}$	3.9 pF
Anode to cathode and heater	$C_{a/kf}$	0.4 pF
	$C_{a'/k'f}$	0.3 pF
Grid to anode, cathode and heater	$C_{g/akf}$	3.7 pF
Grid to cathode and heater	$C_{g/kf}$	1.6 pF
Anode to grid	$C_{ag}$	1.7 pF

**SHOCK AND VIBRATION RESISTANCE**

The following test conditions are applied to assess the mechanical quality of the tube. These conditions are not intended to be used as normal operating conditions.

Shock

The tube is subjected 5 times in each of 4 positions to an acceleration of 500 g supplied by an NRL shock machine with the hammer lifted over an angle of 30°.

## SHOCK AND VIBRATION RESISTANCE (continued)

### Vibration

The tube is subjected during 32 hours in each of 3 positions to a vibration frequency of 50 Hz with an acceleration of 2.5 g.

### LIFE

Production samples are tested to be within the end of life values (column III)

### LIMITING VALUES (Absolute max. rating system)

Anode voltage	$V_a$	max.	330 V
Anode dissipation	$W_a$	max.	1.1 W
Cathode current	$I_k$	max.	20 mA
Grid resistor with fixed bias	$R_g$	max.	1 M $\Omega$
Voltage between cathode and heater	$V_{kf}$	max.	100 V
Bulb temperature	$t_{bulb}$	max.	165 °C

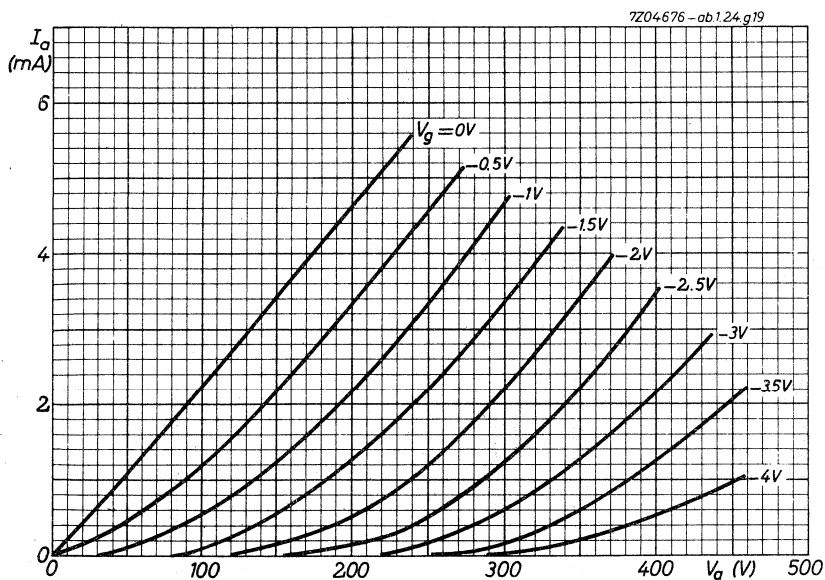

## S.Q. DUAL CONTROL PENTODE

Special quality dual control pentode designed for use as amplifier and mixer.

QUICK REFERENCE DATA	
Life test	1000 hours
Mechanical quality	Shock and vibration resistant
Base	Subminiature
Heating	Indirect
	A. C. or D. C. ; Parallel supply
Heater voltage	$V_f$ 6.3 V
Heater current	$I_f$ 150 mA
Mutual conductance anode to grid No.1	$S_{ag_1}$ 3.2 mA/V
Mutual conductance anode to grid No.3	$S_{ag_3}$ 0.5 mA/V

### DIMENSIONS AND CONNECTIONS

Base: Subminiature

Dimensions in mm

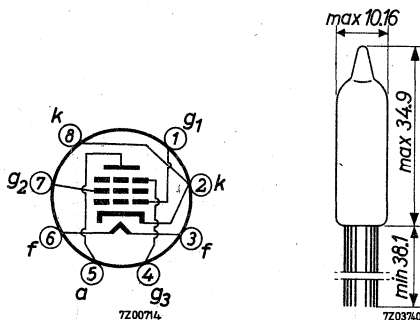

Connections should not be soldered nearer than 5 mm to the seal.

Leads should not be bent nearer than 1.5 mm to the seal.

## CHARACTERISTICS

Column I Nominal value or setting of the tube

II Range values for equipment design: Initial spread

III Range values for equipment design: End of life

		I	II	III	
Heater voltage	$V_f$	6.3			V
Heater current	$I_f$	150	140 - 160		mA
Anode voltage	$V_a$	100			V
Grid No.2 voltage	$V_{g2}$	100			V
Grid No.3 voltage	$V_{g3}$	0			V
Cathode resistor	$R_k$	150			$\Omega$
Anode current	$I_a$	5.3	3.7 - 6.9		mA
Grid No.2 current	$I_{g2}$	4.0	2.8 - 5.4		mA
Mutual conductance;					
anode to grid No.1	$S_{ag1}$	3.2	2.7 - 4.0	$\Delta S$ : max. 20 %	mA/V
anode to grid No.3	$S_{ag3}$	0.5			mA/V
Internal resistance	$R_i$	110			k $\Omega$
<u>Negative grid No.1 current</u>	$-I_{g1}$		max. 0.3	max. 1.0	$\mu A$
Grid No.1 resistor $R_{g1} = 1 M\Omega$					
Anode voltage	$V_a$	100			V
Grid No.2 voltage	$V_{g2}$	100			V
Grid No.3 voltage	$V_{g3}$	-1			V
Cathode resistor	$R_k$	150			$\Omega$
Anode current	$I_a$	4.0			mA
Grid No.2 current	$I_{g2}$	5.8			mA
Mutual conductance;					
anode to grid No.1	$S_{ag1}$	1.95			mA/V
anode to grid No.3	$S_{ag3}$		0.5 - 1.8		mA/V
Internal resistance	$R_i$	50			k $\Omega$

## CHARACTERISTICS (continued)

		I	II	III	
<u>Grid No. 1 cut-off voltage</u>	$-V_{g1}$		max. 7.5		V
Anode voltage	$V_a$	100			V
Grid No. 2 voltage	$V_{g2}$	100			V
Anode current	$I_a$	100			$\mu A$
<u>Grid No. 3 cut-off voltage</u>	$-V_{g3}$		max. 8.0		V
Anode voltage	$V_a$	100			V
Grid No. 2 voltage	$V_{g2}$	100			V
Anode current	$I_a$	100			$\mu A$
<u>Leakage current between cathode and heater</u>	$I_{kf}$		max. 5	max. 10	$\mu A$
Voltage between cathode and heater $V_{kf} = 100$ V					
<u>Insulation resistance between two electrodes</u>	$R_{ins}$		min. 100	min. 50	$M\Omega$
Voltage between electrodes = 100 V					
<u>Vibrational noise output</u>	$V_o$		max. 40		mV
Anode supply voltage	$V_{ba}$	100			V
Anode resistor	$R_a$	10			$k\Omega$
Grid No. 2 voltage	$V_{g2}$	100			V
Grid No. 3 voltage	$V_{g3}$	0			V
Cathode by pass capacitor $C = 1000 \mu F$					
Cathode resistor $R_k = 150 \Omega$					
Vibration frequency 40 Hz					
Acceleration 15 g					

**CAPACITANCES:** With external shield

		I	II	
Grid No.1 to grid No.2, grid No.3, cathode and heater	$C_{g_1/g_2g_3}$ kf	4.0	3.5 - 4.5	pF
Grid No.3 to grid No.1, grid No.2, cathode and heater	$C_{g_3/g_2g_1}$ kf	4.0	3.5 - 4.5	pF
Anode to grid No.2, grid No.3, cathode and heater	$C_{a/g_2g_3}$ kf	3.4	2.9 - 3.9	pF
Anode to grid No.1	$C_{ag_1}$		max.0.02	pF
Anode to grid No.3	$C_{ag_3}$		max. 1.1	pF
Grid No.1 to grid No.3	$C_{g_1g_3}$		max.0.15	pF

**SHOCK AND VIBRATION RESISTANCE**

The following test conditions are applied to assess the mechanical quality of the tube. These conditions are not intended to be used as normal operating conditions.

Shock

The tube is subjected 5 times in each of 4 positions to an acceleration of 500 g supplied by an NRL shock machine with the hammer lifted over an angle of 30°.

Vibration

The tube is subjected during 32 hours in each of 3 positions to a vibration frequency of 25 Hz with an acceleration of 2.5 g.

**LIFE**

Production samples are tested to be within the end of life values (column III) during 1000 hours.



**LIMITING VALUES** (Absolute max. rating system)

Anode voltage	$V_{a_0}$	max.	330 V
Anode voltage	$V_a$	max.	165 V
Anode dissipation	$W_a$	max.	1.1 W
Grid No.3 voltage	$V_{g_3}$	max.	30 V
Grid No.3 negative voltage	$-V_{g_3}$	max.	55 V
Grid No.2 voltage	$V_{g_2}$	max.	155 V
Grid No.2 dissipation	$W_{g_2}$	max.	0.7 W
Grid No.1 voltage	$V_{g_1}$	max.	0 V
Grid No.1 negative voltage	$-V_{g_1}$	max.	55 V
Grid No.1 resistor	$R_{g_1}$	max.	1.2 M $\Omega$
Cathode current	$I_k$	max.	16 mA
Voltage between cathode and heater;			
D.C. component	$V_{kf}$	max.	200 V
peak value	$V_{kfp}$	max.	200 V
Bulb temperature	$t_{bulb}$	max.	220 °C

Heater voltage: The average heater voltage should be 6.3 V.

Variations of the heater voltage exceeding the range of 6.0 V to 6.6 V will shorten the tube life.

The tolerance of heater current (column II) should be taken into account.

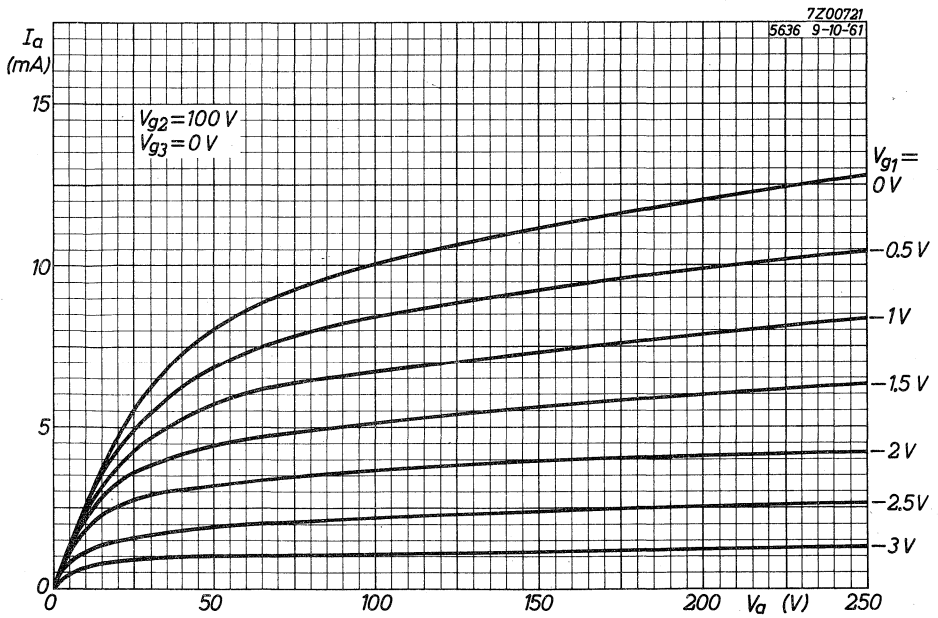
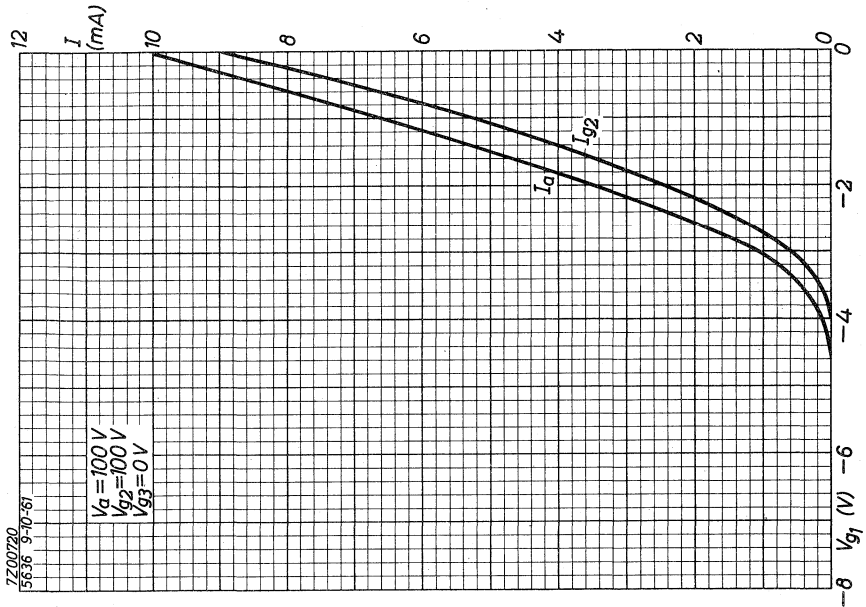

## S.Q. OUTPUT PENTODE

Special quality pentode designed for use as output tube and video amplifier.

QUICK REFERENCE DATA	
Life test	1000 hours
Mechanical quality	Shock and vibration resistant
Base	Subminiature
Heating	Indirect A.C. or D.C., parallel supply
Heater voltage	$V_f$ 6.3 V
Heater current	$I_f$ 450 mA
Mutual conductance	S 9 mA/V
Anode current	$I_a$ 21 mA

### DIMENSIONS AND CONNECTIONS

Base: Subminiature

Dimensions in mm

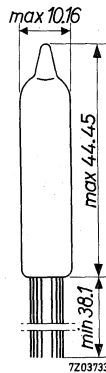
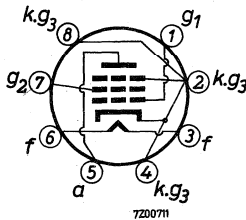

Connections should not be soldered nearer than 5 mm to the seal.  
Leads should not be bent nearer than 1.5 mm to the seal.

## CHARACTERISTICS

Column I Nominal value or setting of the tube

II Range values for equipment design: Initial spread

III Range values for equipment design: End of life value

		I	II	III	
Heater voltage	$V_f$	6.3			V
Heater current	$I_f$	450	420-480		mA
Anode voltage	$V_a$	150			V
Grid No. 2 voltage	$V_{g_2}$	100			V
Cathode resistor	$R_k$	100			$\Omega$
Anode current	$I_a$	21	14-28		mA
Grid No. 2 current	$I_{g_2}$	4.0	2-6		mA
Mutual conductance	S	9.0	7.5-10.5	$\Delta S$ : max. 20%	mA/V
Internal resistance	$R_i$	50			k $\Omega$
<u>Negative grid No. 1 current</u>	$-I_{g_1}$		max. 1.0	max. 2.0	$\mu A$
Grid No. 1 resistor $R_{g_1} = 1 M\Omega$					
<u>Grid No. 1 cut-off voltage</u>	$-V_{g_1}$	14			
Anode voltage	$V_a$	150			V
Grid No. 2 voltage	$V_{g_2}$	100			V
Anode current	$I_a$		max. 75		$\mu A$
<u>Leakage current between cathode and heater</u>	$I_{kf}$		max. 15	max. 60	$\mu A$
Voltage between cathode and heater $V_{kf} = 100 V$					
<u>Insulation resistance between two electrodes</u>	$R_{ins}$		min. 100	min. 50	$M\Omega$
Voltage between electrodes $V = 100 V$					

## CHARACTERISTICS (continued)

	I	II	III	
<u>Vibrational noise output</u>	$V_o$	max. 100		$mV_{eff}$
Anode supply voltage	$V_{ba}$	150		V
Anode resistor	$R_a$	2		$k\Omega$
Grid No.2 voltage	$V_{g2}$	100		V
Cathode resistor	$R_k$	100		$\Omega$
Cathode by pass capacitor $C_k = 1000 \mu F$				
Grid No.1 resistor $R_{g1} = 0.1 M\Omega$				
Vibration frequency = 40 Hz				
Acceleration = 15 g				

## CAPACITANCES With external shield, inside diameter 10.3 mm

	I	II	
Grid No.1 to grid No.2, grid No.3, cathode and heater	$C_{g1/g2} k_{g3f}$	9	8-10 pF
Anode to grid No.2, grid No.3, cathode and heater	$C_a/g2 k_{g3f}$	8	7-9 pF
Anode to grid No.1	$C_{ag1}$		max.0.13 pF

## SHOCK AND VIBRATION RESISTANCE

The following test conditions are applied to assess the mechanical quality of the tube. These conditions are not intended to be used as normal operating conditions.

Shock

The tube is subjected 5 times in each of 4 positions to an acceleration of 500 g supplied by an NRL shock machine with the hammer lifted over an angle of  $30^\circ$ .

Vibration

The tube is subjected during 32 hours in each of 3 positions to a vibration frequency of 50 Hz with an acceleration of 2.5 g.

**LIFE**

Production samples are tested to be within the end of life values (column III) during 1.000 hours.

**LIMITING VALUES** (Absolute max. rating system)

Anode voltage	$V_{a_0}$	max.	330 V
Anode voltage	$V_a$	max.	165 V
Anode dissipation	$W_a$	max.	4 W
Grid No. 2 voltage	$V_{g_2}$	max.	155 V
Grid No. 2 dissipation	$W_{g_2}$	max.	1 W
Grid No. 1 voltage	$V_{g_1}$	max.	0 V
Grid No. 1 negative voltage	$-V_{g_1}$	max.	55 V
Grid No. 1 resistor with fixed bias	$R_{g_1}$	max.	100 k $\Omega$
with automatic bias	$R_{g_1}$	max.	500 k $\Omega$
Cathode current	$I_k$	max.	40 mA
Voltage between cathode and heater, d. c. component	$V_{kf}$	max.	200 V
peak value	$V_{kfp}$	max.	200 V
Bulb temperature	$t_{bulb}$	max.	220 $^{\circ}$ C

Heater voltage: The average heater voltage should be 6.3 V

Variations of the heater voltage exceeding the range of 6.0 to 6.6 V will shorten the tube life.

**OPERATING CHARACTERISTICS**Output tube class A

Anode voltage	$V_a$	150 V
Grid No. 2 voltage	$V_{g_2}$	100 V
Cathode resistor	$R_k$	100 $\Omega$
Load resistance	$R_{a\sim}$	9 k $\Omega$
Input voltage	$V_i$	2 $V_{RMS}$
Output power	$W_o$	1 W

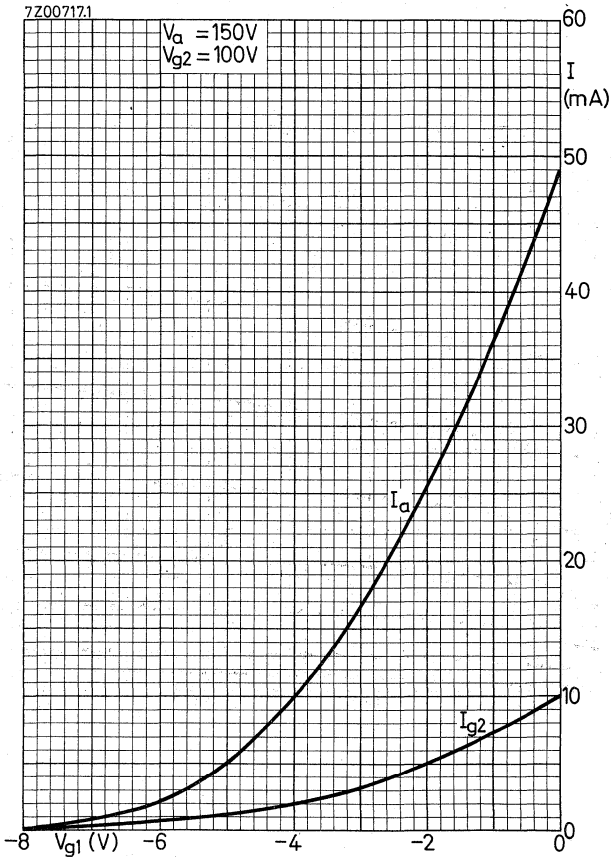

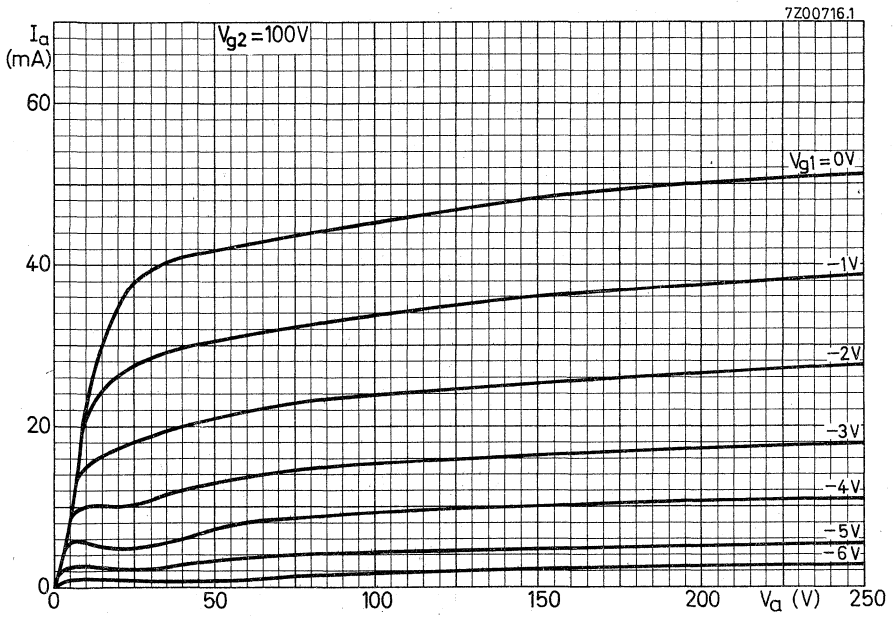



## S.Q. TUBE

Special quality pentode designed for use as wide-band amplifier.

QUICK REFERENCE DATA	
Life test	1000 hours
Mechanical quality	Shock and vibration resistant
Base	Miniature 7 pin
Heating	Indirect A.C. or D.C.; parallel supply
Heater voltage	$V_f$ 6.3 V
Heater current	$I_f$ 175 mA
Mutual conductance	$S$ 5 mA/V
Sharp cut off	

### DIMENSIONS AND CONNECTIONS

Dimensions in mm

Base: Miniature 7 pin

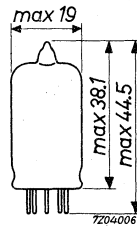
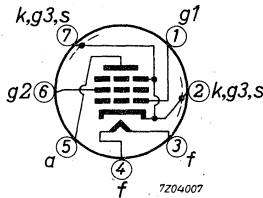

## CHARACTERISTICS

Column I Nominal value or setting of the tube

II Range values for equipment design: Initial spread

		I	II	
Heater voltage	$V_f$	6.3		V
Heater current	$I_f$	175	160 - 190	mA
Anode voltage	$V_a$	120		V
Grid No.2 voltage	$V_{g2}$	120		V
Grid No.1 voltage	$-V_{g1}$	2		V
Anode current	$I_a$	7.5	5 - 11	mA
Grid No.2 current	$I_{g2}$	2.5	0.8 - 4.0	mA
Mutual conductance	S	5	3.8 - 6.2	mA/V
Internal resistance	$R_i$	0.34		MΩ
Negative grid current	$-I_{g1}$		max. 0.1	μA
Anode supply voltage	$V_{ba}$	120		V
Grid No.2 voltage	$V_{g2}$	120		V
Anode resistor	$R_a$	0.1		MΩ
Grid No.1 voltage	$-V_{g1}$	10		V
Anode current	$I_a$		max. 200	μA
<u>Grid No.1 cut off voltage</u>	$-V_{g1}$	8.5		V
Anode voltage	$V_a$	120		V
Grid No.2 voltage	$V_{g2}$	120		V
Anode current	$I_a$	10		μA
<u>Leakage current between cathode and heater</u>	$I_{kf}$		max. 10	μA
Voltage between cathode and heater $V_{kf} = 100$ V				
<u>Insulation resistance between two electrodes</u>	R		min. 100	MΩ

**CAPACITANCES.** With external shield

Grid No.1 to grid No.2, grid No.3  
cathode and heater

	I	II	
$C_{g_1/g_2g_3kf}$	4.0	3.4 - 4.6	pF

Anode to grid No.2, grid No.3  
cathode and heater

$C_{a/g_2g_3kf}$	2.85	2.45 - 3.25	pF
------------------	------	-------------	----

Anode to grid No.1

$C_{ag_1}$		max. 0.02	pF
------------	--	-----------	----

Grid No.1 to grid No.2

$C_{g_1g_2}$	1.4		pF
--------------	-----	--	----

**SHOCK AND VIBRATION RESISTANCE**

The following test conditions are applied to assess the mechanical quality of the tube. These conditions are not intended to be used as normal operating conditions.

Shock

The tube is subjected 5 times in each of 4 positions to an acceleration of 500 g supplied by an NRL shock machine with the hammer lifted over an angle of 30°.

Vibration

The tube is subjected during 32 hours in each of 3 positions to a vibration frequency of 50 Hz with an acceleration of 2.5 g.

**LIFE**

Production samples are tested to be within the end of life values (column III) during 1000 hours.

**LIMITING VALUES** (Absolute max. rating system)

Anode voltage	$V_{a_0}$	max.	600 V
	$V_a$	max.	200 V
Grid No.2 voltage	$V_{g_{20}}$	max.	600 V
	$V_{g_2}$	max.	155 V
Grid No.1 voltage	$-V_{g_1}$	max.	50 V
	$+V_{g_1}$	max.	0 V
Anode dissipation	$W_a$	max.	1.65 W
Grid No.2 dissipation	$W_{g_2}$	max.	0.55 W
Cathode current	$I_k$	max.	20 mA
Grid No.1 current	$I_{g_1}$	max.	1 mA
Grid No.1 resistor	$R_{g_1}$	max.	0.1 M $\Omega$
Voltage between cathode and heater	$V_{kf}$	max.	135 V
Bulb temperature	$t_{bulb}$	max.	165 °C <sup>1)</sup>

Heater voltage: The average heater voltage should be 6.3 V.

Variations of the heater voltage exceeding the range of 5.7 V to 7.0 V will shorten the tube life.

The tolerance of heater current (column II) should be taken into account.

<sup>1)</sup> Tube life and reliability of performance will be enhanced by operation at lower temperatures.

**S.Q. TRIODE**

Special quality triode designed for use as R.F. amplifier, oscillator (max. frequency 1000 MHz), and AF amplifier.

QUICK REFERENCE DATA	
Life test	500 hours
Mechanical quality	Shock and vibration resistant
Base	Subminiature
Heating	Indirect
	A.C. or D.C., Parallel supply
Heater voltage	$V_f$ 6.3 V
Heater current	$I_f$ 150 mA
Anode current	$I_a$ 13 mA
Mutual conductance	S 6.5 mA/V

**DIMENSIONS AND CONNECTIONS**

Base : Subminiature

Dimensions in mm

Socket: BI 506 81

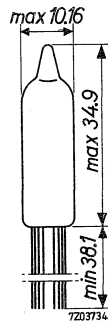
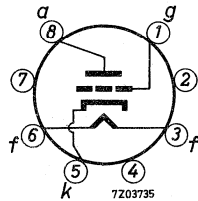

Connections should not be soldered nearer than 5 mm to the seal.

Leads should not be bent nearer than 1.5 mm to the seal.

On request the tube can also be delivered with shortened leads of 4.7-5.4 mm.

## CHARACTERISTICS

Column I Nominal value or setting of the tube

II Range values for equipment design: Initial spread

III Range values for equipment design: End of life

		I	II	III	
Heater voltage	$V_f$	6.3			V
Heater current	$I_f$	150	138 - 162		mA
Anode voltage	$V_a$	100			V
Cathode resistor	$R_k$	150			$\Omega$
Anode current	$I_a$	8.5	6 - 11		mA
Mutual conductance	S	5.8	4.8 - 6.8	$\Delta S: \text{max. } 20\%$	mA/V
Internal resistance	$R_i$	4.65			k $\Omega$
Amplification factor	$\mu$	27	23 - 31		-
Anode voltage	$V_a$	100			V
Negative grid voltage	$-V_g$		max. 7		V
Anode current	$I_a$	100			$\mu A$
<u>Cut off voltage</u>	$-V_g$	7			V
Anode voltage	$V_a$	100			V
Anode current	$I_a$	10			$\mu A$
Anode voltage	$V_a$	150			V
Cathode resistor	$R_k$	180			$\Omega$
Anode current	$I_a$	13			mA
Mutual conductance	S	6.5			mA/V
Internal resistance	$R_i$	4.15			k $\Omega$
Amplification factor	$\mu$	27			-
Negative grid current ( $R_k = 380 \Omega$ )	$-I_g$		max.0.4	max.0.6	$\mu A$
<u>Cut off voltage</u>	$-V_g$	11			V
Anode voltage	$V_a$	150			V
Anode current	$I_a$	10			$\mu A$

**CHARACTERISTICS** (continued)

		I	II	III	
<u>Leakage current between cathode and heater</u>	$I_{kf}$			max. 10	$\mu A$
Voltage between cathode and heater = 100 V					
<u>Insulation between two electrodes</u>	$R_{ins}$			min. 50	$M\Omega$

**CAPACITANCES**

		With external shield		Without shield	
		I	I	II	
Anode to cathode and heater	$C_{a/kf}$	2.4	0.7	0.5 - 0.9	pF
Grid to cathode and heater	$C_{g/kf}$	2.4	2.2	1.6 - 2.8	pF
Anode to grid	$C_{ag}$	1.3	1.45	1.1 - 1.8	pF

**SHOCK AND VIBRATION RESISTANCE**

The following test conditions are applied to assess the mechanical quality of the tube. These conditions are not intended to be used as normal operating conditions.

Shock

The tube is subjected 5 times in each of 4 positions to an acceleration of 500 g supplied by an NRL shock machine with the hammer lifted over an angle of 30°.

Vibration

The tube is subjected during 32 hours in each of 3 positions to a vibration frequency of 50 Hz with an acceleration of 2.5 g.

**LIFE**

Production samples are tested to be within the end of life values (column III) under the following conditions during 500 hours:

Anode voltage	$V_a$	=	100 V
Cathode resistor	$R_k$	=	150 $\Omega$
Grid resistor	$R_g$	=	1 $M\Omega$
Voltage between cathode and heater (cath. neg.)	$V_{kf}$	=	200 V

**LIMITING VALUES** (Absolute max. rating system)

Anode voltage	$V_a$	max.	165 V
Grid voltage	$-V_g$	max.	55 V
Anode dissipation	$W_a$	max.	3.3 W
Anode current	$I_a$	max.	22 mA
Grid current	$I_g$	max.	5.5 mA
Grid resistor	$R_g$	max.	1.2 $M\Omega$
Voltage between cathode and heater	$V_{kf}$	max.	200 V
Bulb temperature <sup>1)</sup>	$t_{bulb}$	max.	250 °C

Heater voltage: The average heater voltage should be 6.3 V.

Variations of the heater voltage exceeding the range of 6.0 V to 6.6 V will shorten the tube life.

The tolerance of heater current (column II) should be taken into account.

**OPERATING CHARACTERISTICS**As R.F. amplifier

Anode voltage	$V_a$	100	150 V
Cathode resistor	$R_k$	150	180 $\Omega$
Anode current	$I_a$	8.5	13 mA
Mutual conductance	S	5.8	6.5 mA/V

As oscillator

Anode voltage	$V_a$	150	V
Anode current	$I_a$	20	mA
Output power	$W_o$	0.9	W
Frequency	f	500	MHz

<sup>1)</sup> In the interest of optimum life performance it is recommended to reduce the bulb temperature by fixing the bulb directly to the chassis with a metal clamp. (ZE1100)



## OPERATING CHARACTERISTICS (continued)

As A.F. amplifier Fig.1

Anode supply voltage	$V_b$	100	200	100	200	100	200	V
Anode resistor	$R_a$	47	47	100	100	270	270	$k\Omega$
Grid resistor	$R_g$	270	270	270	270	270	270	$k\Omega$
Grid resistor next stage	$R_g$	100	100	270	270	470	470	$k\Omega$
Cathode resistor	$R_k$	1.0	0.82	2.2	1.8	8.2	5.6	$k\Omega$
Input voltage	$V_i$	0.5	1.0	0.5	1.0	0.5	1.0	$V_{RMS}$
Voltage gain	$V_o/V_i$	16.4	19.0	16.4	18.6	14.8	16.2	-
Total distortion	$d_{tot}$	3.9	4.0	3.0	3.2	2.8	3.2	%

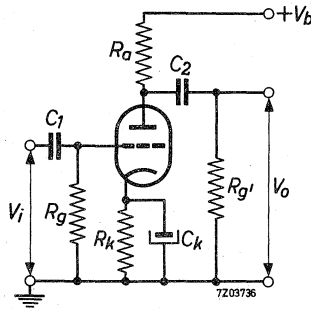
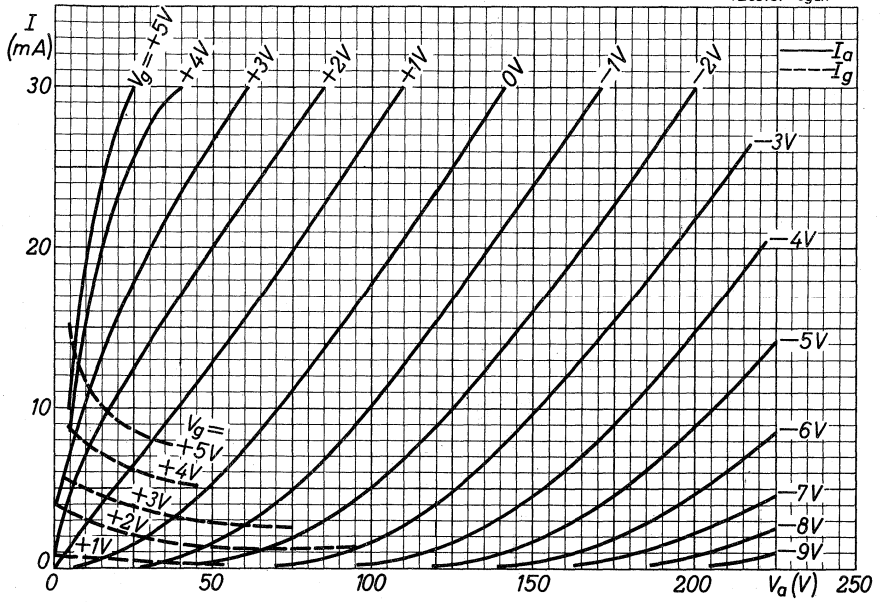

Fig.1

7203737-egah



## S.Q. TUBE

Special quality pentode designed for use as R.F. amplifier.

### QUICK REFERENCE DATA

Life test	1000 hours	
Mechanical quality	Shock and vibration resistant	
Base	Miniature 7 pin	
Heating	Indirect A.C. or D.C.; parallel supply	
Heater voltage	$V_f$	6.3 V
Heater current	$I_f$	175 mA
Sharp cut-off		
Double control		

### DIMENSIONS AND CONNECTIONS

Dimensions in mm

Base: Miniature 7 pin

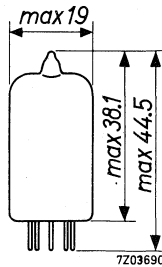
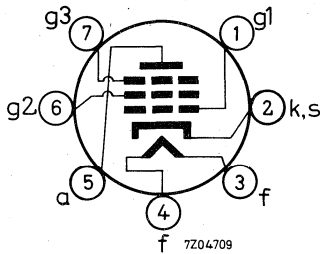

## CHARACTERISTICS

Column I Nominal value or setting of the tube

II Range values for equipment design: Initial spread

III Range values for equipment design: End of life

		I	II	III	
Heater voltage	$V_f$	6.3			V
Heater current	$I_f$	175	160 - 190		mA
Anode voltage	$V_a$	120			V
Grid No.2 voltage	$V_{g2}$	120			V
Grid No.3 voltage	$V_{g3}$	0			V
Grid No.1 voltage	$-V_{g1}$	2			V
Anode current	$I_a$	5.2	2.5 - 9.0		mA
Grid No.2 current	$I_{g2}$	3.5	max.5.5		mA
Mutual conductance, grid No.1	$S_{g1}$	3.2	2.5 - 4.5	$\Delta S$ max.20%	mA/V
Mutual conductance, grid No.3	$S_{g3}$	0.47			mA/V
Internal resistance	$R_i$	150			k $\Omega$
Negative grid No.1 current	$-I_{g1}$		max.0.1	max. 0.2	$\mu A$
Anode voltage	$V_a$	120			V
Grid No.2 voltage	$V_{g2}$	120			V
Grid No.3 voltage	$-V_{g3}$	3			V
Grid No.1 voltage	$-V_{g1}$	2			V
Anode current	$I_a$	3.6			mA
Grid No.2 current	$I_{g2}$	4.8			mA
Mutual conductance, grid No.1	$S_{g1}$	1.85			mA/V
Mutual conductance, grid No.3	$S_{g3}$	0.7			mA/V
Anode voltage	$V_a$	120			V
Grid No.2 voltage	$V_{g2}$	120			V
Grid No.3 voltage	$-V_{g3}$	5			V
Grid No.1 voltage	$-V_{g1}$	2			V
Mutual conductance, grid No.3	$S_{g3}$	1.2	0.7 - 1.7		mA/V

## CHARACTERISTICS (continued)

		I	II	III	
<u>Cut-off voltage</u>	$-V_{g1}$	8			V
Anode voltage	$V_a$	120			V
Grid No.2 voltage	$V_{g2}$	120			V
Grid No.3 voltage	$V_{g3}$	0			V
Anode current	$I_a$		max. 50		$\mu A$
<u>Cut-off voltage</u>	$-V_{g1}$	6			V
Anode voltage	$V_a$	120			V
Grid No.2 voltage	$V_{g2}$	120			V
Grid No.3 voltage	$V_{g3}$	0			V
Anode current	$I_a$		min. 5		$\mu A$
<u>Cut-off voltage</u>	$-V_{g1}$	3			V
	$-V_{g3}$	5.5			V
Anode voltage	$V_a$	120			V
Grid No.2 voltage	$V_{g2}$	120			V
Anode current	$I_a$		min. 5		$\mu A$
<u>Cut-off voltage</u>	$-V_{g1}$	3			V
	$-V_{g3}$	10			V
Anode voltage	$V_a$	120			V
Grid No.2 voltage	$V_{g2}$	120			V
Anode current	$I_a$		max. 50		$\mu A$
<u>Cut-off voltage</u>	$-V_{g1}$	2			V
	$-V_{g2}$	15			V
Anode voltage	$V_a$	120			V
Grid No.2 voltage	$V_{g2}$	120			V
Anode current	$I_a$	10			$\mu A$
<u>Leakage current between cathode and heater</u>	$I_{kf}$		max. 10	max. 10	$\mu A$
Voltage between cathode and heater $V_{kf} = 100$ V					
Cathode negative					

**CHARACTERISTICS** (continued)Vibrational noiseAnode voltage  $V_a = 120$  VGrid No.2 voltage  $V_{g_2} = 120$  VGrid No.1 voltage  $-V_{g_1} = 2$  VGrid No.3 voltage  $V_{g_3} = 0$  VAnode resistor  $R_a = 10$  k $\Omega$ 

Vibration frequency = 50 Hz

Acceleration = 10 g

 $V_o$ 

I

II

max. 150 mV

**CAPACITANCES** With external screenAnode to grid No.3, grid No.2,  
cathode, heater and screen $C_{a/g_3g_2kfs}$ 

3.0

2.6 - 3.4

pF

Grid No.1 to grid No.3, grid No.2,  
cathode, heater and screen $C_{g_1/g_3g_2kfs}$ 

4.0

3.5 - 4.5

pF

Grid No.1 to grid No.3

 $C_{g_1g_3}$ 

max. 150

mpF

Anode to grid No.1

 $C_{ag_1}$ 

max. 20

mpF

Grid No.1 to grid No.3, grid No.2,  
cathode, heater and screen $C_{g_1/g_3g_2kfs}$ 

5.5

pF

Cathode current  $I_k = 12$  mA

Frequency = 100 MHz

**SHOCK AND VIBRATION RESISTANCE**

The following test conditions are applied to assess the mechanical quality of the tube. These conditions are not intended to be used as normal operating conditions.

Shock

The tube is subjected 5 times in each of 4 positions to an acceleration of 500 g supplied by an NRL shock machine with the hammer lifted over an angle of  $30^\circ$ .

Vibration

The tube is subjected during 32 hours in each of 3 positions to a vibration frequency of 50 Hz with an acceleration of 2.5 g.

**LIFE**

Production samples are tested to be within the end of life values (column III) during 1000 hours.

**LIMITING VALUES** (Absolute max. rating system)

Anode voltage	$V_a$	max.	200 V
Grid No.2 voltage	$V_{g2}$	max.	155 V
Grid No.3 voltage	$V_{g3}$	max.	30 V
Anode dissipation	$W_a$	max.	1.85 W
Grid No.2 dissipation	$W_{g2}$	max.	0.85 W
Cathode current	$I_k$	max.	20 mA
Voltage between cathode and heater	$V_{kf}$	max.	100 V
Grid resistor with fixed bias	$R_{g1}$	max.	1 M $\Omega$
Bulb temperature	$t_{bulb}$	max.	165 °C

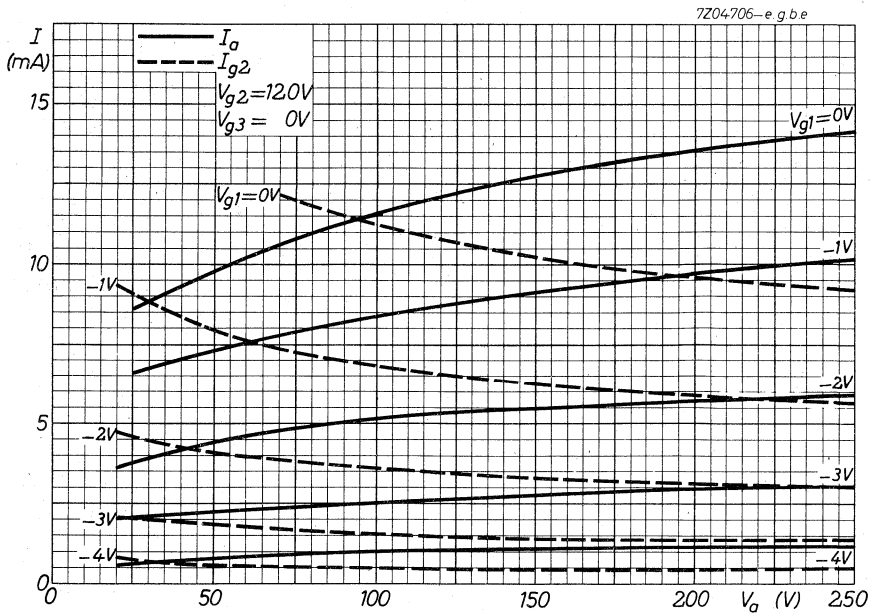

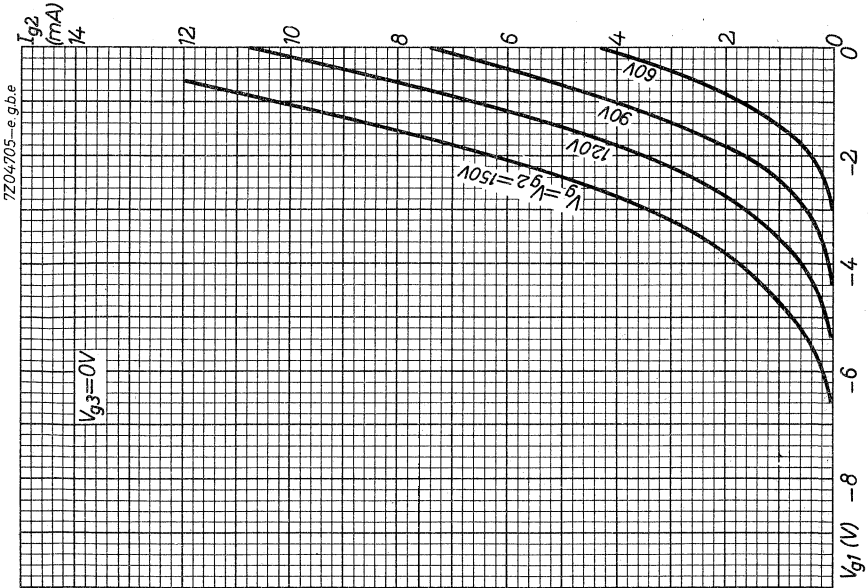
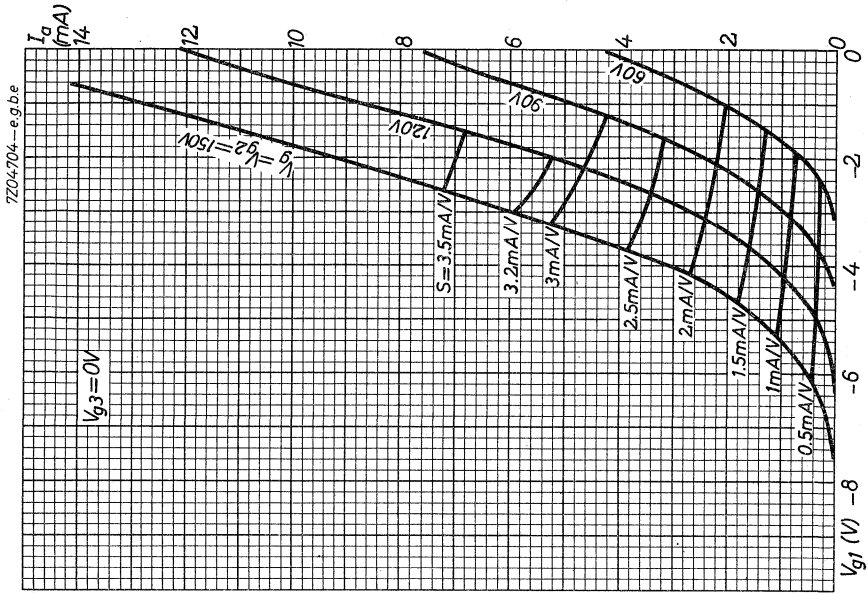



## S.Q. DOUBLE DIODE

Special quality double diode designed for use as detector or low-current power rectifier.

### QUICK REFERENCE DATA

Life test	1000 hours	
Mechanical quality	Shock and vibration resistant	
Base	Miniature 7 pin	
Heating	Indirect	
	A. C. or D. C.	
	Series or parallel supply	
Heater voltage	$V_f$	6.3 V
Heater current	$I_f$	300 mA
Diode current	$I_d$	10 mA
Inverse peak voltage	$V_{invp}$	360 V

### DIMENSIONS AND CONNECTIONS

Base: Miniature 7 pin

Dimensions in mm

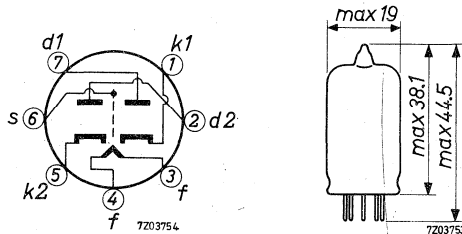

**CHARACTERISTICS** (both systems if applicable)

Column I Nominal value or setting of the tube

II Range values for equipment design: Initial spread

		I	II	
Heater voltage	$V_f$	6.3		V
Heater current	$I_f$	300	275 - 325	mA
<u>Diode current</u>	$I_d$		min. 40	mA
Diode voltage	$V_d$	10		V
<u>Diode current</u>	$I_{do}$		2 - 20	$\mu$ A
Diode voltage	$V_d$	0		V
Series resistor	R	40		k $\Omega$
<u>Difference in diode current</u>	$ I_d - I_d' $		max. 5	$\mu$ A
Diode voltage	$V_d$	0		V
Series resistor	R	40		k $\Omega$
<u>Leakage current between cathode and heater</u>	$I_{kf}$		max. 10	$\mu$ A
Voltage between cathode and heater $V_{kf} = 100$ V				
<u>Insulation resistance between two electrodes</u>	$R_{ins}$		min. 100	M $\Omega$
Voltage between electrodes = 300 V				
<u>Resonant frequency</u>		700		MHz
<b>CAPACITANCES</b>				
Diode to cathode heater and screen	$C_d/kfs$	3.2	2.4 - 4	pF
Cathode to diode heater and screen	$C_k/dfs$	3.9	3.1 - 4.7	pF
Diode No.1 to diode No.2	$C_{d_1d_2}$		max.0.026	pF

**SHOCK AND VIBRATION RESISTANCE**

The following test conditions are applied to assess the mechanical quality of the tube. These conditions are not intended to be used as normal operating conditions.

Shock

The tube is subjected 5 times in each of 4 positions to an acceleration of 700 g supplied by an NRL shock machine with the hammer lifted over an angle of 45°.

Vibration

The tube is subjected during 32 hours in each of 3 positions to a vibration frequency of 50 Hz with an acceleration of 2.5 g.

**LIFE**

Production samples are tested during 1000 hours.

**LIMITING VALUES** (Absolute max. rating system) (Per system if applicable)

Inverse peak voltage	$V_{invp}$	max.	360 V
Diode current	$I_d$	max.	10 mA
Diode peak current	$I_{dp}$	max.	60 mA
Peak voltage between cathode and heater	$V_{kfp}$	max.	360 V
Bulb temperature	$t_{bulb}$	max.	165 °C

Heater voltage: The average heater voltage should be 6.3 V.

Variations of the heater voltage exceeding the range of 5.7 V to 7.0 V will shorten the tube life.

**OPERATING CHARACTERISTICS**As full wave power rectifier

A.C. supply voltage	$V_{tr}$	2 x 165	$V_{RMS}$
Capacitance	C	8	$\mu F$
Series resistor per diode	$R_s$	300	$\Omega$
Load resistor	$R_l$	11	$k\Omega$
D.C. current	$I_o$	min. 16	mA

As half wave rectifier (per system)

A.C. supply voltage	$V_{tr}$	117	$V_{RMS}$
Capacitance	C	8	$\mu F$
Series resistor	$R_s$	300	$\Omega$
D.C. current	$I_o$	9	mA

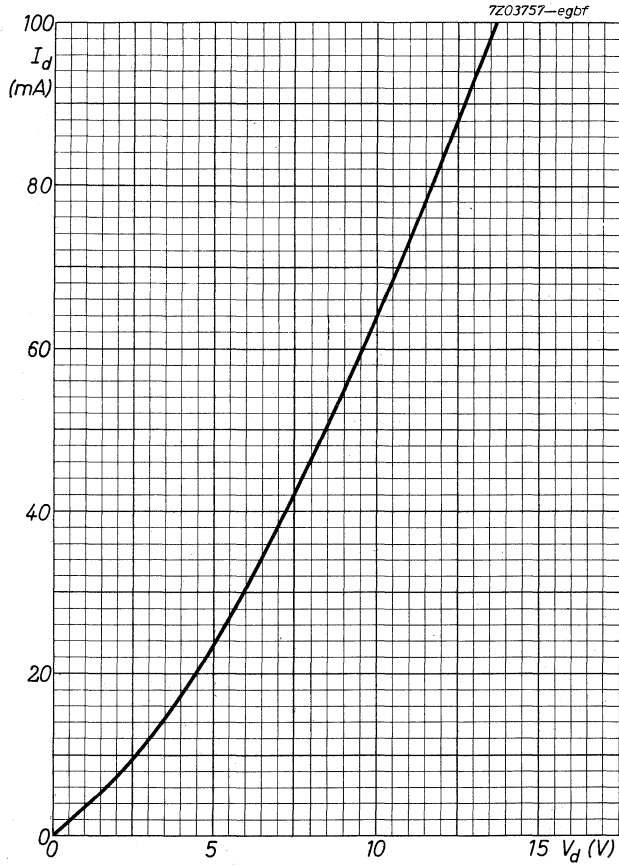

**S.Q. TUBE**

Special quality pentode designed for use A.F. and R.F. amplifier (max. frequency 400 MHz)



QUICK REFERENCE DATA		
Life test	1000 hours	
Mechanical quality	Shock and vibration resistant	
Base	Subminiature	
Heating	Indirect	
	A.C. or D.C.; parallel supply	
Heater voltage	$V_f$	6.3 V
Heater current	$I_f$	150 mA
Mutual conductance	S	5 mA/V
Anode current	$I_a$	7.5 mA

**DIMENSIONS AND CONNECTIONS**

Dimensions in mm

Base: Subminiature

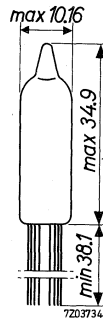
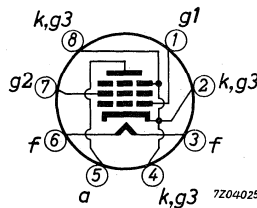

Leads should not be soldered nearer than 5 mm to the seal  
 Leads should not be bent nearer than 2 mm to the seal.

## CHARACTERISTICS

Column I Nominal value or setting of the tube

II Range values for equipment design: Initial spread

III Range values for equipment design: End of life

		I	II	III	
Heater voltage	$V_f$	6.3			V
Heater current	$I_f$	150	140 - 160		mA
Anode supply voltage	$V_{ba}$	100			V
Grid No.2 supply voltage	$V_{bg_2}$	100			V
Cathode resistor	$R_k$	150			$\Omega$
Anode current	$I_a$	7.5	5.5 - 9.5		mA
Grid No.2 current	$I_{g_2}$	2.4	1.5 - 3.3		mA
Mutual conductance	S	5	4.2 - 5.8	min. 3.5	mA/V
Internal resistance	$R_i$	260	min. 175		k $\Omega$
Negative grid No.1 current	$-I_{g_1}$		max. 0.3	max. 0.8	$\mu$ A
<u>Cut-off voltage</u>	$-V_{g_1}$	9			V
Anode voltage	$V_a$	100			V
Grid No.2 voltage	$V_{g_2}$	100			V
Anode current	$I_a$	10	max. 50		$\mu$ A
<u>Leakage current between cathode and heater</u>	$I_{kf}$		max. 5	max. 10	$\mu$ A
Voltage between cathode and heater $V_{kf} = 100$ V					
<u>Vibrational noise output</u>	$V_o$		max. 60		mV <sub>RMS</sub>
Anode supply voltage $V_{ba} = 100$ V					
Grid No.2 supply voltage $V_{bg_2} = 100$ V					
Cathode resistor $R_k = 150 \Omega$					
Anode resistor $R_a = 10$ k $\Omega$					
Cathode by-pass capacitor $C_k = 1000 \mu$ F					
Vibration frequency = 50 Hz					
Acceleration = 15 g					
Insulation resistance					
a to all at V = 300 V	$R_{ins}$		min. 100		M $\Omega$
g <sub>1</sub> to all at V = 100 V	$R_{ins}$		min. 100		M $\Omega$

**CAPACITANCES**

		With external screen		Without external shield		
		I	II	I	II	
Anode to grid No. 2, cathode, heater and screen	$C_{a/g_2}$ kfs	3.4	2.9-3.9	1.9		pF
Grid No. 1 to grid No. 2, cathode, heater and screen	$C_{g_1/g_2}$ kfs	4.2	3.5-4.9	4.0		pF
Anode to grid No. 1	$C_{ag_1}$		max. 15		max. 30	mpF

**SHOCK AND VIBRATION RESISTANCE**

The following test conditions are applied to assess the mechanical quality of the tube. These conditions are not intended to be used as normal operating conditions.

Shock

The tube is subjected 5 times in each of 4 positions to an acceleration of 500 g supplied by an NRL shock machine with the hammer lifted over an angle of 30°.

Vibration

The tube is subjected during 32 hours in each of 3 positions to a vibration frequency of 50 Hz with an acceleration of 2.5 g.

**LIFE**

Production samples are tested to be within the end of life values (column III) under the following conditions during 1000 hours.

Anode supply voltage	$V_{ba}$	100 V
Grid No. 2 supply voltage	$V_{bg_2}$	100 V
Cathode resistor	$R_k$	150 $\Omega$

**LIMITING VALUES** (Absolute max. rating system)

Anode voltage	$V_{a_0}$	max. 330 V
	$V_a$	max. 165 V
Grid No. 2 voltage	$V_{g_{20}}$	max. 330 V
	$V_{g_2}$	max. 155 V
Anode dissipation	$W_a$	max. 1.1 W
Grid No. 2 dissipation	$W_{g_2}$	max. 0.55 W

**LIMITING VALUES** (continued)

Cathode current	$I_k$	max. 16.5 mA
Grid No.1 voltage	$-V_{g1}$	max. 55 V
Voltage between cathode and heater	$V_{kf}$	max. 200 V
Grid No.1 resistor	$R_{g1}$	max. 1.1 M $\Omega$
Bulb temperature	$t_{bulb}$	max. 220 °C

**OPERATING CHARACTERISTICS** Fig.1

Supply voltage	V	100	150	100	150	100	150	V
Anode resistor	$R_a$	100	100	270	270	470	470	k $\Omega$
Grid No.2 resistor	$R_{g2}$	0.22	0.27	0.68	0.82	1.2	1.5	k $\Omega$
Grid No.1 resistor	$R_{g1}$	0.27	0.27	0.47	0.47	1.0	1.0	M $\Omega$
Total distortion ( $V_i = 0.1$ VRMS)	$d_{tot}$	2.8	1.5	2.5	2.4	2.3	3.0	%
Voltage gain ( $V_i = 0.1$ VRMS)	$V_o/V_i$	82	115	95	132	117	167	
Total distortion ( $+I_{g1} = 0.3$ $\mu$ A)	$d_{tot}$	4.9	4.8	4.7	4.9	5.0	4.8	%
Voltage gain ( $+I_{g1} = 0.3$ $\mu$ A)	$V_o/V_i$	77	109	91	128	114	159	
Input voltage ( $+I_{g1} = 0.3$ $\mu$ A)	$V_i$	0.23	0.2	0.15	0.16	0.14	0.14	VRMS

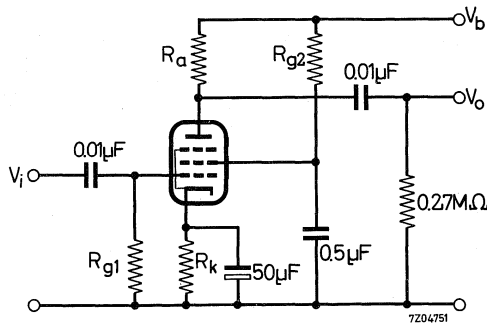
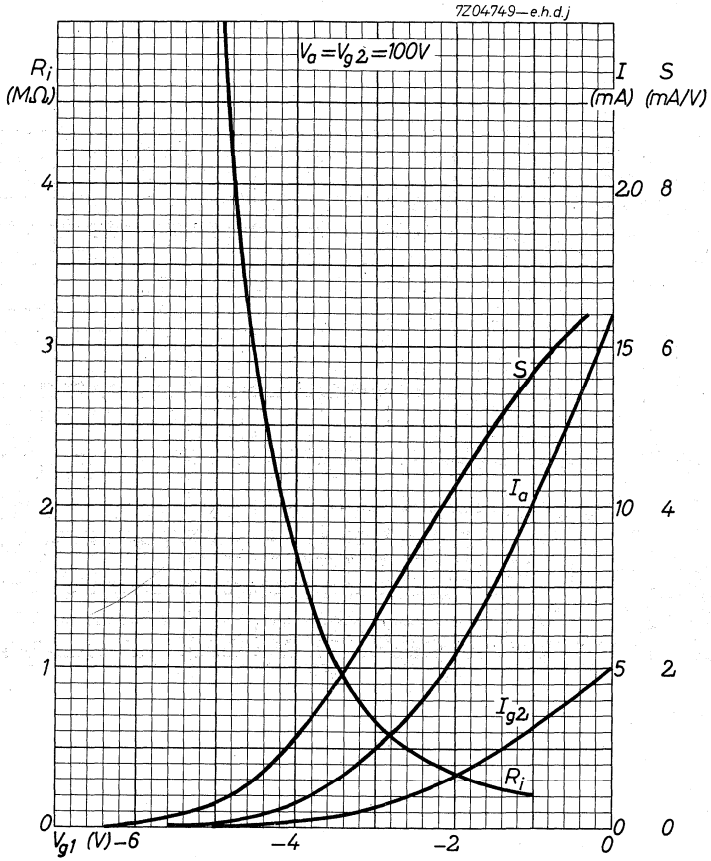
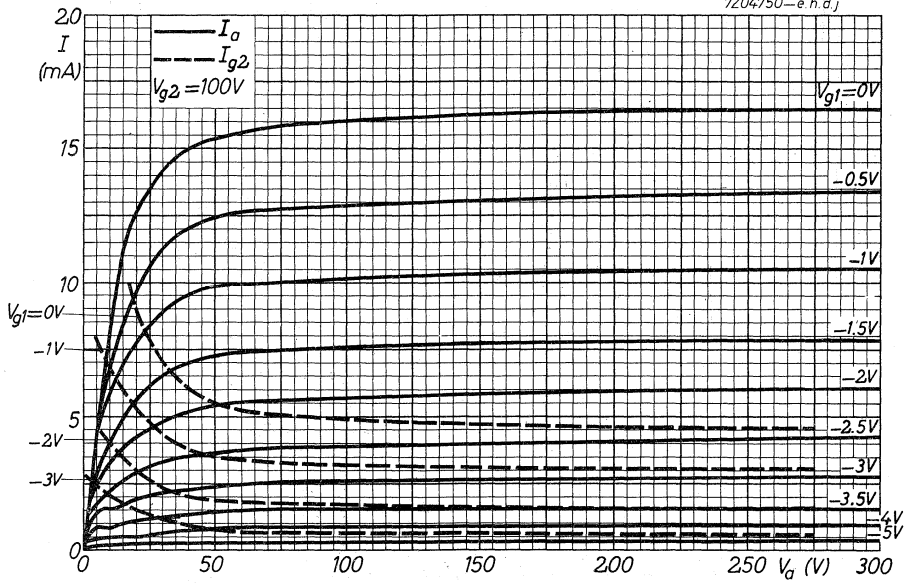

Fig.1





7204750-e.h.d.j



**S.Q. TUBE**

Special quality pentode designed for use as controlled R.F. or I.F. amplifier (max. freq. 400 MHz).

**QUICK REFERENCE DATA**

Life test	1 000 hours	
Mechanical quality	Shock and vibration resistant	
Base	Subminiature	
Heating	Indirect A.C. or D.C.; parallel supply	
Heater voltage	$V_f$	6.3 V
Heater current	$I_f$	150 mA
Anode current	$I_a$	7.2 mA
Mutual conductance	S	4.5 mA/V

**DIMENSIONS AND CONNECTIONS**

Dimensions in mm

Base: Subminiature

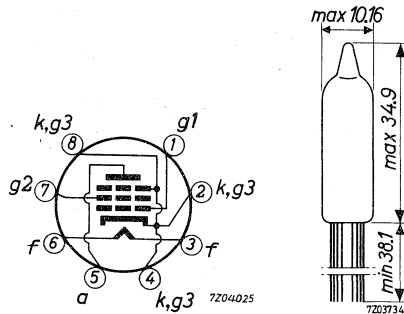

Leads should not be soldered nearer than 5 mm to the seal  
 Leads should not be bent nearer than 2 mm to the seal

## CHARACTERISTICS

Column I Nominal value or setting of the tube

II Range values for equipment design: Initial spread

III Range values for equipment design: End of life

		I	II	III	
Heater voltage	$V_f$	6.3			V
Heater current	$I_f$	150	140-160		mA
Anode voltage	$V_a$	100			V
Grid No.2 voltage	$V_{g2}$	100			V
Cathode resistor	$R_k$	120			$\Omega$
Anode current	$I_a$	7.2	5.2-9.2		mA
Grid No.2 current	$I_{g2}$	2.0	1.0-3.0		mA
Mutual conductance	S	4.5	3.8-5.2	$\Delta S$ max. 25%	mA/V
Internal resistance	$R_i$	260	min.175		k $\Omega$
Negative grid No.1 current	$-I_{g1}$		max.0.3	max. 0.8	$\mu A$
Mutual conductance	S	25	1- 75		$\mu A/V$
Grid No.1 voltage	$-V_{g1}$	14			V
<u>Leakage current between cathode and heater</u>	$I_{kf}$		max. 5	max. 10	$\mu A$
Voltage between cathode and heater $V_{kf} = 100$ V					
Insulation resistance between electrodes	$R_{ins}$		min.100		M $\Omega$

## CHARACTERISTICS (continued)

		I	II		
<u>Vibrational noise output</u>		$V_o$	max. 60	mV <sub>RMS</sub>	
Anode supply voltage					
$V_{ba} = 100 \text{ V}$					
Grid No.2 supply voltage					
$V_{bg_2} = 100 \text{ V}$					
Cathode resistor $R_k = 120 \Omega$					
Anode resistor $R_a = 10 \text{ k}\Omega$					
Grid No.1 resistor $R_{g_1} = 1 \text{ M}\Omega$					
Cathode bypass capacitor					
$C_k = 1000 \mu\text{F}$					
Vibration frequency = 50 Hz					
Acceleration = 15 g					
<b>CAPACITANCES</b> With external shield					
Anode to grid No.2, cathode heater and screen		$C_{a/g_2\text{kfs}}$	3.4	2.9 - 3.9	pF
Grid No.1 to grid No.2, cathode heater and screen		$C_{g_1/g_2\text{kfs}}$	4.2	3.8 - 4.8	pF
Anode to grid No.1		$C_{ag_1}$		max. 15	mpF

**SHOCK AND VIBRATION RESISTANCE**

The following test conditions are applied to assess the mechanical quality of the tube. These conditions are not intended to be used as normal operating conditions.

Shock

The tube is subjected 5 times in each of 4 positions to an acceleration of 500 g supplied by an NRL shock machine with the hammer lifted over an angle of  $30^\circ$ .

Vibration

The tube is subjected during 32 hours in each of 3 positions to a vibration frequency of 50 Hz with an acceleration of 2.5 g.

**LIFE**

Production samples are tested to be within the end of life values (column III) under the following conditions during 1000 hours.

Anode voltage	$V_a$	100 V
Grid No.2 voltage	$V_{g2}$	100 V
Cathode resistor	$R_k$	120 $\Omega$

**LIMITING VALUES** (Absolute max. rating system)

Anode voltage	$V_a$	max.	165 V
Grid No.2 voltage	$V_{g2}$	max.	155 V
Anode dissipation	$W_a$	max.	1.1 W
Grid No.2 dissipation	$W_{g2}$	max.	0.55 W
Cathode current	$I_k$	max.	16.5 mA
Voltage between cathode and heater	$V_{kf}$	max.	200 V
Grid No.1 resistor	$R_{g1}$	max.	1.2 $M\Omega$
Bulb temperature	$t_{bulb}$	max.	220 $^{\circ}C$

## S.Q. TUBE

Special quality pentode designed for use as A. F. power output tube.

QUICK REFERENCE DATA	
Life test	1000 hours
Mechanical quality	Shock and vibration resistant
Base	Subminiature
Heating	Indirect A. C. or D. C. ; parallel supply
Heater voltage	$V_f$ 6.3 V
Heater current	$I_f$ 450 mA
Anode current	$I_a$ 30 mA
Output power	$W_o$ 1.0 W

## DIMENSIONS AND CONNECTIONS

Dimensions in mm

Base: Subminiature

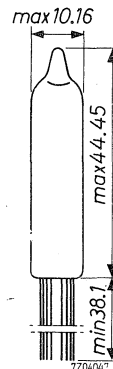
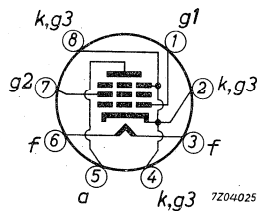

The leads should not be soldered nearer than 5 mm to the seal and should not be bent nearer than 1.5 mm to the seal.

## CHARACTERISTICS

- Column I Nominal value or setting of the tube  
 II Range values for equipment design: Initial spread  
 III Range values for equipment design: End of life

		I	II	III	
Heater voltage	$V_f$	6.3			V
Heater current	$I_f$	450	420 - 480		mA
Anode voltage	$V_a$	100			V
Grid No. 2 voltage	$V_{g_2}$	100			V
Grid No. 1 voltage	$-V_{g_1}$	9			V
Anode current	$I_a$	30			mA
Grid No. 2 current	$I_{g_2}$	2.2			mA
Mutual conductance	S	4.2			mA/V
Anode supply voltage	$V_{ba}$	109			V
Grid No. 2 supply voltage	$V_{bg_2}$	109			V
Cathode resistor	$R_k$	270			$\Omega$
Anode current	$I_a$	30	23 - 37		mA
Grid No. 2 current	$I_{g_2}$	2.2	max. 4.0		mA
Mutual conductance	S	4.2	3.5 - 4.9		mA/V
Internal resistance	$R_i$	15	min. 10		$k\Omega$
<u>Negative grid No. 1 current</u>	$-I_{g_1}$	1		2	$\mu A$
<u>Output power</u>	$W_o$	1.0	min. 0.75	$\Delta W_o$ : max. 25%	W
Load resistance $R_{a\sim} = 3 k\Omega$					
<u>Leakage current between cathode and heater</u>	$I_{kf}$		max. 15	max. 60	$\mu A$
Voltage between cathode and heater $V_{kf} = 100 V$					



**CHARACTERISTICS** (continued)Vibrational noise output

	II	
$V_o$	max. 100	mVRMS

Anode supply voltage  $V_{ba} = 110$  V

Grid No. 2 supply voltage  $V_{bg_2} = 110$  V

Cathode resistor  $R_k = 270 \Omega$

Cathode by-pass capacitor  $C_k = 1000$  pF

Anode resistor  $R_a = 2$  k $\Omega$

Vibration frequency = 50 Hz

Acceleration = 15 g

**CAPACITANCES**

Anode to grid No. 2, cathode,  
heater and screen

	I	II	
$C_{a/g_2kfs}$	7.2	6.5 - 8.5	pF
Grid No. 1 to grid No. 2 cathode, heater and screen	$C_{g_1/g_2kfs}$	6.5	5.5 - 7.5 pF
Anode to grid No. 1	$C_{ag_1}$	max. 0.2	pF

**SHOCK AND VIBRATION RESISTANCE**

The following test conditions are applied to assess the mechanical quality of the tube. These conditions are not intended to be used as normal operating conditions.

Shock

The tube is subjected 5 times in each of 4 positions to an acceleration of 500 g supplied by an NRL shock machine with the hammer lifted over an angle of 30°.

Vibration

The tube is subjected during 32 hours in each of 3 positions to a vibration frequency of 50 Hz with an acceleration of 2.5 g.

**LIFE**

Production samples are tested to be within the end of life values (column III) under the following conditions during 1000 hours

Anode supply voltage	$V_{ba}$	109	V
Grid No.2 supply voltage	$V_{bg2}$	109	V
Cathode resistor	$R_k$	270	$\Omega$

**LIMITING VALUES** (Absolute max. rating system)

Anode voltage	$V_{a0}$	max.	330	V
	$V_a$	max.	165	V
Grid No. 2 voltage	$V_{g20}$	max.	310	V
	$V_{g2}$	max.	155	V
Grid No. 1 voltage	$-V_{g1}$	max.	55	V
Anode dissipation	$W_a$	max.	4	W
Grid No. 2 dissipation	$W_{g2}$	max.	1	W
Cathode current	$I_k$	max.	50	mA
Peak voltage between cathode and heater	$V_{kf}$	max.	200	V
Grid No. 1 resistor, fixed bias	$R_{g1}$	max.	0.1	$M\Omega$
	automatic bias	$R_{g1}$	max.	0.55 $M\Omega$
Bulb temperature	$t_{bulb}$	max.	220	$^{\circ}C$

**S.Q. TUBE**

Special quality double triode designed for use as R.F. amplifier and oscillator.

QUICK REFERENCE DATA		
Life test	1000 hours	
Mechanical quality	Shock and vibration resistant	
Base	Subminiature	
Heating	Indirect	
	A.C. or D.C.; parallel supply	
Heater voltage	$V_f$	6.3 V
Heater current	$I_f$	300 mA
Anode current	$I_a$	6.5 mA
Mutual conductance	S	5.4 mA/V

**DIMENSIONS AND CONNECTIONS**

Dimensions in mm

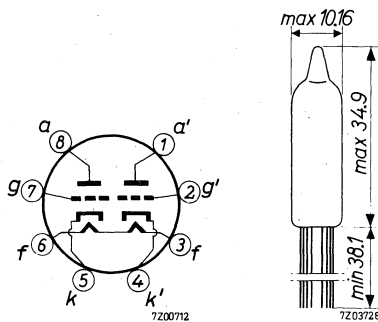

Connections should not be soldered nearer than 5 mm to the seal.

Leads should not be bent nearer than 1.5 mm to the seal.

## CHARACTERISTICS (both sections if applicable)

Column I Nominal value or setting of the tube

II Range values for equipment design: Initial spread

III Range values for equipment design: End of life

		I	II	III	
Heater voltage	$V_f$	6.3			V
Heater current	$I_f$	300	280 - 320		mA
Anode voltage	$V_a$	100			V
Cathode resistor	$R_k$	150			$\Omega$
Anode current	$I_a$	6.5	4.5 - 8.5		mA
Difference in anode current of both systems	$ I_a - I_a' $		max. 1.6		mA
Mutual conductance	$S$	5.4	4.45 - 6.35	$\Delta S$ : max. 25 %	mA/V
Amplification factor	$\mu$	35	30 - 40		
Internal resistance	$R_i$	6.5			k $\Omega$
<u>Cut-off voltage</u>	$-V_g$		max. 6.5		V
Anode voltage	$V_a$	100			V
Anode current	$I_a$	100			$\mu$ A
<u>Negative grid current</u>	$-I_g$		max. 0.3	max. 1.0	$\mu$ A
Anode voltage	$V_a$	150			V
Cathode resistor	$R_k$	300			$\Omega$
Grid resistor	$R_g$	1			M $\Omega$
<u>Leakage current between cathode and heater</u>	$I_{kf}$		max. 5	max. 10	$\mu$ A
Voltage between cathode and heater $V_{kf} = 100$ V					
<u>Insulation resistance between two electrodes</u>	$R_{ins}$		min. 100	min. 50	M $\Omega$
Voltage between electrodes = 100 V					

## CHARACTERISTICS (continued)

		I	II	III	
<u>Vibrational noise output</u>	$V_o$		max. 35		mV <sub>RMS</sub>
Anode supply voltage $V_{ba}$					
Anode resistor $R_a$					
Cathode resistor $R_k$					
Cathode by pass capacitor $C$					
Vibration frequency					
Acceleration					
<b>CAPACITANCES</b>					
Grid to cathode and heater	$C_{g/kf}$	2.4	1.8 - 3.0		pF
Anode to cathode and heater	$C_{a/kf}$	0.28	0.20 - 0.36		pF
	$C_{a^*/k^*f}$	0.32	0.22 - 0.42		pF
Anode to grid	$C_{ag}$	1.5	1.2 - 1.8		pF
Grid to grid other section	$C_{gg'}$		max. 0.013		pF
Anode to anode other section	$C_{aa'}$		max. 0.52		pF

**SHOCK AND VIBRATION RESISTANCE**

The following test conditions are applied to assess the mechanical quality of the tube. These conditions are not intended to be used as normal operating conditions.

Shock

The tube is subjected 5 times in each of 4 positions to an acceleration of 500 g supplied by an NRL shock machine with the hammer lifted over an angle of 30°.

Vibration

The tube is subjected during 32 hours in each of 3 positions to a vibration frequency of 50 Hz with an acceleration of 2.5 g.

**LIFE**

Production samples are tested to be within the end of life values (column III) under the following conditions during 1000 hours:

Anode voltage  $V_a = 100$  V

Cathode resistor  $R_k = 150 \Omega$

Voltage between  
cathode and heater  $V_{kf} = 200$  V

**LIMITING VALUES** (Absolute max. rating system)

Anode voltage	$V_{aO}$	max.	330 V
Anode voltage	$V_a$	max.	165 V
Anode dissipation	$W_a$	max.	0.7 W
Anode current	$I_a$	max.	22 mA
Grid voltage	$-V_g$	max.	55 V
Grid current	$I_g$	max.	5.5 mA
Grid resistor	$R_g$	max.	1.1 M $\Omega$
Voltage between cathode and heater d. c. or peak value	$V_{kf}$	max.	200 V
Bulb temperature	$t_{bulb}$	max.	220 °C

Heater voltage: The average heater voltage should be 6.3 V.

Variations of the heater voltage exceeding the range of 6.0 V to 6.6 V will shorten the tube life.

The tolerance of heater current (column II) should be taken into account.

## S.Q. TUBE

Special quality double triode designed for use as series regulator tube in d.c. power supplies, in servo application and as booster triode.

## QUICK REFERENCE DATA

Life test	500 hours
Mechanical quality	Shock and vibration resistant
Base	Octal
Heating	Indirect A.C. or D.C.; parallel supply
Heater voltage	$V_f$ 6.3 V
Heater current	$I_f$ 2.5 A
Anode current	$I_a$ 100 mA (each section)
Mutual conductance	S 6.5 mA/V
Internal resistance	$R_i$ 300 $\Omega$

## DIMENSIONS AND CONNECTIONS

Dimensions in mm

Base: Octal

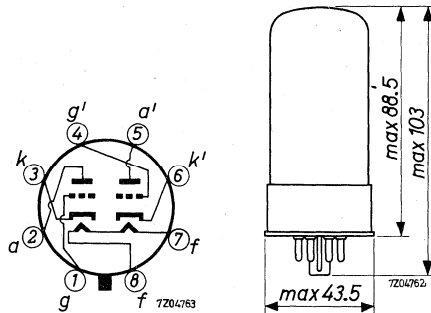

**CHARACTERISTICS**      Each section if applicable

Column I   Nominal value or setting of the tube

II   Range values for equipment design: Initial spread

		I	II	
Heater voltage	$V_f$	6.3		V
Heater current	$I_f$	2.5	2.26 - 2.74	A
Anode voltage	$V_a$	100		V
Cathode resistor	$R_k$	300		$\Omega$
Anode current	$I_a$	100		mA
Mutual conductance	S	6.5		mA/V
Amplification factor	$\mu$	2		
Internal resistance	$R_i$	300		$\Omega$
Anode supply voltage	$V_{ba}$	135		V
Cathode resistor	$R_k$	250		$\Omega$
Anode current      1)	$I_a$	125	100 - 150	mA
Mutual conductance	S	7.0	5.8 - 8.2	mA/V
Amplification factor	$\mu$	2.0	1.4 - 2.6	
Internal resistance	$R_i$	280		$\Omega$
Negative grid current (g connected to g')	$-I_g$		max. 4.0	$\mu A$

1) Max. duration 1 s

 Operation with  $W_a$  and  $I_a$  at the absolute maximum limiting values.



**CHARACTERISTICS** (continued)

	I	II	
<u>Vibrational noise output</u>	$V_o$	max. 0.2	$V_{RMS}$
Two sections in parallel			
Anode supply voltage $V_{ba} = 135$ V			
Grid voltage $-V_g = 7$ V			
Anode resistor $R_a = 2$ k $\Omega$			
Vibration frequency = 25 Hz			
Acceleration = 2.5 g			
<b>CAPACITANCES</b> Each system if applicable			
Anode to grid	$C_{ag}$	8.6	pF
Anode to cathode and heater	$C_{a/kf}$	2.5	pF
Grid to cathode and heater	$C_{g/kf}$	5.5	pF
Cathode to heater	$C_{kf}$	7	pF
Anode to anode other section	$C_{aa'}$	2.2	pF
Grid to grid other section	$C_{gg'}$	0.5	pF

**SHOCK AND VIBRATION RESISTANCE**

The following test conditions are applied to assess the mechanical quality of the tube. These conditions are not intended to be used as normal operating conditions.

Shock

The tube is subjected 5 times in each of 4 positions to an acceleration of 500 g supplied by an NRL shock machine with the hammer lifted over an angle of 30°.

Vibration

The tube is subjected during 32 hours in each of 3 positions to a vibration frequency of 25 Hz with an acceleration of 2.5 g.

**LIFE**

Production samples are tested during 500 hours.

**LIMITING VALUES** (Absolute max. rating system)

Anode voltage	$V_{a0}$	max. 550 V
	$V_a$	max. 250 V
Anode inverse peak voltage	$V_{a\text{ inv}p}$	max. 3 kV
Duty factor max. 0.15		
Pulse duration max. 10 $\mu$ sec		
Cathode current	$I_k$	max. 125 mA
Grid peak voltage	$-V_{gp}$	max. 2.3 kV
Duty factor max. 0.15		
Pulse duration max. 10 $\mu$ sec		
Anode dissipation	$W_a$	max. 13 W
Voltage between cathode and heater, peak	$V_{kfp}$	max. 300 V
Grid resistor	Automatic bias	$R_g$ max. 1.0 $M\Omega$
	Fixed bias	$R_g$ max. 0.1 $M\Omega$ <sup>1)</sup>
Bulb temperature	$t_{bulb}$	max. 260 $^{\circ}C$

<sup>1)</sup> With fixed bias the anode circuit should contain a protective resistance to provide a minimum drop of 15 V d.c. at the normal operating conditions. When two or more sections are used in parallel at dissipations approaching the rated maximum, separate anode and cathode resistors must be used to assist load sharing.

When combined fixed and automatic bias is used, the cathode bias portion should have a minimum value of 7.5 V d.c. at the normal operating conditions.  $R_g$  should then not exceed 0.1  $M\Omega$ .

## S.Q. TUBE

Special quality double triode designed for use as amplifier mixer and oscillator.

QUICK REFERENCE DATA	
Life test	1000 hours
Mechanical quality	Shock and vibration resistant
Base	Subminiature
Heating	Indirect A.C. or D.C.; parallel supply
Heater voltage	$V_f$ 6.3 V
Heater current	$I_f$ 300 mA
Anode current	$I_a$ 8.5 mA
Mutual conductance	$S$ 5 mA/V

## DIMENSIONS AND CONNECTIONS

Dimensions in mm

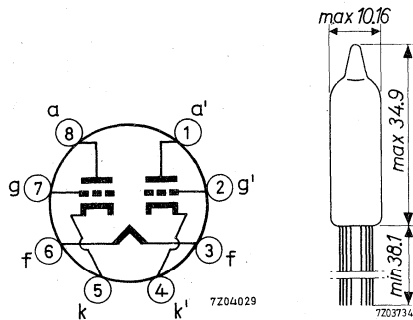

The leads should not be soldered nearer than 5 mm to the seal and should not be bent nearer than 1.5 mm to the seal.

**CHARACTERISTICS** (Each system if applicable)

Column I Nominal values or setting of the tube

II Range values for equipment design: Initial spread

III Range values for equipment design: End of life

		I	II	III	
Heater voltage	$V_f$	6.3			V
Heater current	$I_f$	300	280 - 320		mA
Anode voltage	$V_a$	100			V
Grid voltage	$-V_g$	1.9			V
Anode current	$I_a$	8.5			mA
Mutual conductance	S	5			mA/V
Amplification factor	$\mu$	20	17 - 23		
Internal resistance	$R_i$	4			k $\Omega$
Anode voltage	$V_a$	100			V
Cathode resistor	$R_k$	220			$\Omega$
Anode current	$I_a$	8.5	6.0 - 11		mA
Difference in anode current of two sections	$ I_a - I_a' $		max. 2		mA
Mutual conductance	S	5	4.1 - 5.9	min. 3.5	mA/V
<u>Negative grid current</u>	$-I_g$		max. 0.3	max. 1.0	$\mu$ A
<u>Cut-off voltage</u>	$-V_g$	9			V
Anode voltage	$V_a$	100			V
Anode current	$I_a$		max. 100		$\mu$ A
<u>Leakage current between cathode and heater</u>	$I_{kf}$		max. 5	max. 10	$\mu$ A

Voltage between cathode  
and heater  $V_{kf} = 100$  V

**CHARACTERISTICS** (continued)Vibrational noise output

Anode supply voltage  $V_{ba} = 100$  V  
 Cathode resistor  $R_k = 220 \Omega$   
 Anode resistor  $R_a = 10 \text{ k}\Omega$   
 Grid resistor  $R_g = 0.1 \text{ M}\Omega$   
 Cathode by-pass capacitor  $C_k = 1000 \mu\text{F}$   
 Vibration frequency = 50 Hz  
 Acceleration = 15 g

	I	II	
$V_o$		max. 50	mVRMS
$C_{a/kf}$	0.28	0.2-0.36	pF
$C_{a'/k'f}$	0.32	0.22-0.42	pF
$C_{g/kf}$	1.9	1.4- 2.4	pF
$C_{ag}$	1.5	1.2- 1.8	pF
$C_{gg'}$		max. 13.0	mpF
$C_{aa'}$		max. 0.5	pF

**CAPACITANCES**

Anode to cathode and heater	$C_{a/kf}$	0.28	0.2-0.36	pF
	$C_{a'/k'f}$	0.32	0.22-0.42	pF
Grid to cathode and heater	$C_{g/kf}$	1.9	1.4- 2.4	pF
Anode to grid	$C_{ag}$	1.5	1.2- 1.8	pF
Grid to grid other section	$C_{gg'}$		max. 13.0	mpF
Anode to anode other section	$C_{aa'}$		max. 0.5	pF

**SHOCK AND VIBRATION RESISTANCE**

The following test conditions are applied to assess the mechanical quality of the tube. These conditions are not intended to be used as normal operating conditions.

Shock

The tube is subjected 5 times in each of 4 positions to an acceleration of 500 g supplied by an NRL shock machine with the hammer lifted over an angle of 30°.

Vibration

The tube is subjected during 32 hours in each of 3 positions to a vibration frequency of 50 Hz with an acceleration of 2.5 g.

**LIFE**

Production samples are tested to be within the end of life values (column III) under the following conditions during 1000 hours.

Anode voltage	$V_a$	100 V
Cathode resistor	$R_k$	220 $\Omega$

**LIMITING VALUES** (Absolute max. rating system)

Anode voltage	$V_{a0}$	max. 330	V
	$V_a$	max. 165	V
Grid voltage	$+V_g$	max. 0	V
	$-V_g$	max. 55	V
Grid current	$I_g$	max. 5.5	mA
Anode dissipation	$W_a$	max. 1.1	W
Cathode current	$I_k$	max. 22	mA
Peak voltage between cathode and heater	$V_{kf_p}$	max. 200	V
Grid resistor	$R_g$	max. 1	M $\Omega$
Bulb temperature	$t_{bulb}$	max. 220	$^{\circ}\text{C}$

## S.Q. TUBE

Special quality double triode designed for use as A.F. amplifier.

QUICK REFERENCE DATA	
Life test	1000 hours
Mechanical quality	Shock and vibration resistant
Base	Noval
Heating	Indirect A.C. or D.C.; Parallel supply
Heater voltage	$V_f$ 6.3 or 12.6 V
Heater current	$I_f$ 300 or 150 mA
Anode current	$I_a$ 11.8 mA
Mutual conductance	S 3.2 mA/V

### DIMENSIONS AND CONNECTIONS

Dimensions in mm

Base: Noval

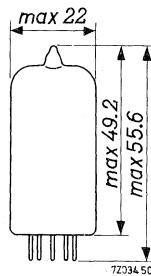
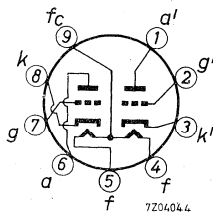

## CHARACTERISTICS (Both sections if applicable)

- Column I Nominal values or setting of the tube  
 II Range values for equipment design: Initial spread  
 III Range values for equipment design: End of life

		I	II	III	
Heater voltage (pin 9 and 4+5)	$V_f$	6.3			V
Heater current	$I_f$	300	276-324		mA
Heater voltage (pin 4 and 5)	$V_f$	12.6			V
Heater current	$I_f$	150			mA
Anode voltage	$V_a$	100			V
Grid voltage	$-V_g$	0			V
Anode current	$I_a$	11.8			mA
Mutual conductance	S	3.2	2.5-4.0		mA/V
Amplification factor	$\mu$	19.5			
Internal resistance	$R_i$	6.25			k $\Omega$
Anode voltage	$V_a$	250			V
Grid voltage	$-V_g$	8.5			V
Anode current	$I_a$	10.5	6.5-14.5		mA
Mutual conductance	S	2.2	1.8-2.6	min. 1.5	mA/V
Amplification factor	$\mu$	17	15.5-18.5		
Internal resistance	$R_i$	7.7			k $\Omega$
<u>Negative grid current</u>	$-I_g$		max. 0.5	max. 0.5	$\mu$ A
<u>Cathode peak current</u>	$I_{kp}$		min. 400		mA
Anode voltage	$V_a$	250			V
Grid voltage	$V_g$	55			V
<u>Cut-off voltage</u>	$-V_g$	25			V
Anode voltage	$V_a$	250			V
Anode current	$I_a$		max. 20		$\mu$ A



## CHARACTERISTICS (continued)

		I	II	III	
<u>Leakage current between cathode and heater</u>	$I_{kf}$		max. 5	max. 5	$\mu A$
Voltage between cathode and heater $V_{kf} = 100$ V					
<u>Vibrational noise output</u>	$V_o$		max. 100		$mV_{RMS}$
Anode voltage $V_a = 250$ V					
Grid voltage $-V_g = 8.5$ V					
Anode resistor $R_a = 2$ k $\Omega$					
Grid resistor $R_g = 0.1$ M $\Omega$					
Vibration frequency = 50 Hz					
Acceleration = 10 g					
<b>CAPACITANCES</b>					
Anode to cathode and heater	$C_{a/kf}$	0.5	0.3- 0.7		pF
	$C_{a'/k'f}$	0.4	0.2- 0.6		pF
Grid to cathode and heater	$C_{g/kf}$	1.6	1.25-1.95		pF
Anode to grid	$C_{ag}$	1.5	1.2- 1.8		pF

**SHOCK AND VIBRATION RESISTANCE**

The following test conditions are applied to assess the mechanical quality of the tube. These conditions are not intended to be used as normal operating conditions.

Shock

The tube is subjected 5 times in each of 4 positions to an acceleration of 500 g supplied by an NRL shock machine with the hammer lifted over an angle of 30°.

Vibration

The tube is subjected during 32 hours in each of 3 positions to a vibration frequency of 50 Hz with an acceleration of 2.5 g.

**LIFE**

Production samples are tested to be within the end of life values (column III) under the following conditions during 1000 hours.

Anode voltage	$V_a$	250 V
Grid voltage	$-V_g$	8.5 V

**LIMITING VALUES** (Absolute max. rating system)

Anode voltage	$V_a$	max. 330 V
Anode dissipation	$W_a$	max. 3 W
Cathode current	$I_k$	max. 22 mA
Grid resistor: fixed bias	$R_{g1}$	max. 0.5 MΩ
	automatic bias	$R_{g1}$
Voltage between cathode and heater	$V_{kf}$	max. 110 V
Bulb temperature	$t_{bulb}$	max. 165 °C

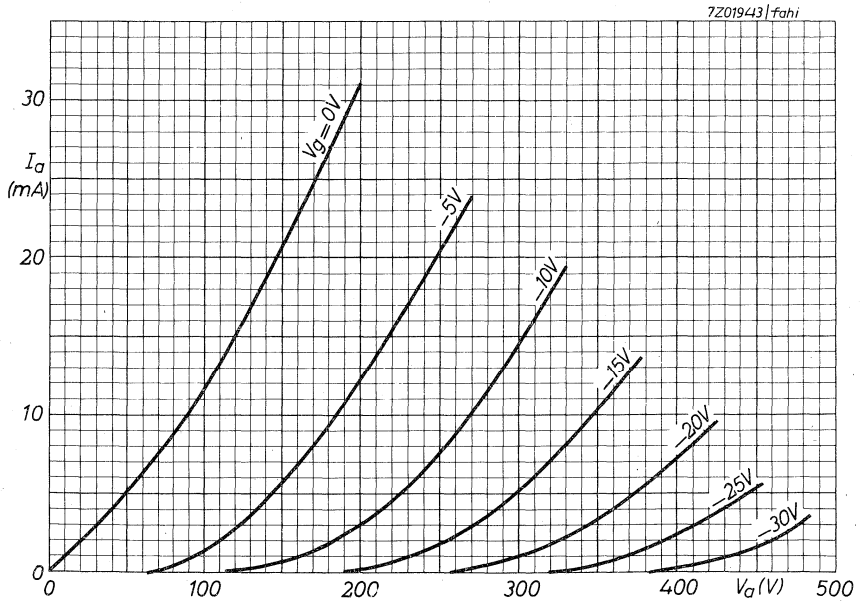

### S.Q. TUBE

Special quality double triode designed for use as R.F. amplifier in grounded grid circuits, frequency changer (max. freq. 300 MHz) in mobile and industrial equipment with intermittent operation, and on-off control applications where operation under cut-off conditions is required.



QUICK REFERENCE DATA	
Life test	500 hours
Low interface resistance	
Mechanical quality	Shock and vibration resistant
Base	Noval. Gold plated pins
Heating	Indirect A.C. or D.C. Parallel or series supply
Heater voltage	$V_f$ 6.3 or 12.6 V
Heater current	$I_f$ 300 or 150 mA
Anode current	$I_a$ 10 mA
Mutual conductance	S 5.5 mA/V

#### DIMENSIONS AND CONNECTIONS

Dimensions in mm

Base: Noval

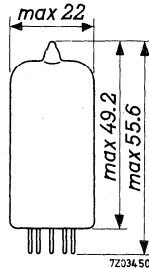
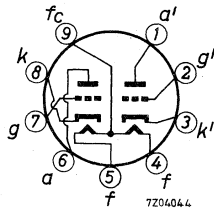

## CHARACTERISTICS

- Column I Nominal value or setting of the tube  
 II Range values for equipment design: Initial spread  
 III Range values for equipment design: End of life

		I	II	III	
Heater voltage (pin 9 and 4 + 5)	$V_f$	6.3			V
Heater current	$I_f$	300			mA
Heater voltage (pin 4 and 5)	$V_f$	12.6			V
Heater current	$I_f$	150	138 - 162		mA
Anode voltage	$V_a$	100			V
Cathode resistor	$R_k$	270			$\Omega$
Anode current	$I_a$	3.3			mA
Mutual conductance	S	4.0			mA/V
Internal resistance	$R_i$	14.3			$k\Omega$
Amplification factor	$\mu$	57			
<u>Cut-off voltage</u>	$-V_g$	5			V
Anode voltage	$V_a$	100			V
Anode current	$I_a$	10			$\mu A$
Anode voltage	$V_a$	250			V
Cathode resistor	$R_k$	200			$\Omega$
Anode current	$I_a$	10	7 - 14		mA
Mutual conductance	S	5.5	4.5 - 6.5	min. 3.8	mA/V
Internal resistance	$R_i$	10.9			$k\Omega$
Amplification factor	$\mu$	60	50 - 70		
Difference in anode current of two systems	$ I_a - I_a' $		max. 3.2		mA
<u>Negative grid current</u>	$-I_g$		max. 0.7	max. 0.7	$\mu A$
<u>Cut-off voltage</u>	$-V_g$	12			V
Anode voltage	$V_a$	250			V
Anode current	$I_a$	10			$\mu A$

**CHARACTERISTICS** (continued)

	I	II	III	
<u>Cut-off voltage</u>	$-V_g$	20		V
Anode supply voltage $V_a = 250$ V	$V_a$	250		V
Anode resistor $R_a = 0.1$ M $\Omega$	$R_a$	0.1		M $\Omega$
Anode current $I_a = \text{max. } 100$ $\mu$ A	$I_a$	max. 100		$\mu$ A
<u>Vibrational noise output</u>	$V_o$	max. 100		mV <sub>RMS</sub>
Anode supply voltage $V_{ba} = 200$ V				
Grid voltage $-V_g = 3$ V				
Anode resistor $R_a = 2$ k $\Omega$				
(two sections in parallel)				
Vibration frequency 25 Hz				
Acceleration 2.5 g				
<u>Leakage current between cathode and heater</u>	$I_{kf}$	max. 10	max. 10	$\mu$ A
Voltage between cathode and heater $V_{kf} = 100$ V				
<u>Insulation resistance between grid and cathode (<math>V = 100</math> V)</u>	$R_{ins}$	min. 100	min. 50	M $\Omega$
anode and cathode ( $V = 300$ V)	$R_{ins}$	min. 100	min. 50	M $\Omega$

**CAPACITANCES** (Both sections if applicable)Without external shield

	I	II	
Anode to grid	$C_{ag}$	1.6	1.3 - 1.9 pF
Grid to cathode and heater	$C_{g/kf}$	2.5	2.0 - 3.0 pF
Anode to cathode and heater	$C_{a/kf}$	0.45	0.2 - 0.7 pF
	$C_{a'/k'f}$	0.38	0.16 - 0.60 pF
Cathode to heater	$C_{kf}$	2.8	2.1 - 3.5 pF
Anode to anode other section	$C_{aa'}$	0.24	0.15 - 0.33 pF
Cathode to grid and heater	$C_{k/gf}$	5.0	pF
Anode to grid and heater	$C_{a/gf}$	1.9	pF
	$C_{a'/g'f}$	1.8	pF
Anode to cathode	$C_{ak}$	0.2	pF
	$C_{a'k'}$	0.24	pF

**CAPACITANCES** (Both sections if applicable) (continued)With external shield connected to the applicable cathode

Anode to grid	$C_{ag}$	1.6 pF
Grid to cathode and heater	$C_{g/kf}$	2.5 pF
Anode to cathode and heater	$C_{a/kf}$	1.2 pF
	$C_{a' / k' f}$	1.3 pF
Cathode to heater	$C_{kf}$	2.8 pF

With external shield connected to the applicable grid

Cathode to grid and heater	$C_{k/gf}$	5.0 pF
Anode to grid and heater	$C_{a/gf}$	2.7 pF
Anode to cathode	$C_{ak}$	0.18 pF
	$C_{a' k'}$	0.2 pF

**SHOCK AND VIBRATION RESISTANCE**

The following test conditions are applied to assess the mechanical quality of the tube. These conditions are not intended to be used as normal operating conditions

Shock

The tube is subjected 5 times in each of 4 positions to an acceleration of 600 g supplied by an NRL shock machine with the hammer lifted over an angle of 42°

Vibration

The tube is subjected during 32 hours in each of 3 positions to a vibration frequency of 25 Hz with an acceleration of 2.5 g

**LIFE**

Production samples are tested to be within the end of life values (column III) under the following conditions during 500 hours

Anode supply voltage	$V_{ba}$	=	250	V
Cathode resistor	$R_k$	=	200	$\Omega$



## OPERATING CHARACTERISTICS

As A.F. amplifier

Resistance of voltage source = 200  $\Omega$ 

Anode supply voltage	$V_{ba}$	90	90	90	90	90	90	V
Anode resistor	$R_a$	0.1	0.1	0.24	0.24	0.51	0.51	M $\Omega$
Cathode resistor	$R_k$	1600	1800	3800	4200	8000	9600	$\Omega$
Grid resistor of next stage	$R_{g'}$	0.1	0.24	0.24	0.51	0.51	1.0	M $\Omega$
Output voltage ( $d_{tot} = 5\%$ )	$V_o$	5.3	7.8	7.2	9.4	8.3	10	V <sub>RMS</sub>
Voltage gain ( $V_o = 2$ V <sub>RMS</sub> )	$V_o/V_i$	26	29	28	30	28	29	
Anode supply voltage	$V_{ba}$	180	180	180	180	180	180	V
Anode resistor	$R_a$	0.1	0.1	0.24	0.24	0.51	0.51	M $\Omega$
Cathode resistor	$R_k$	1100	1400	2800	3300	5600	6700	$\Omega$
Grid resistor of next stage	$R_{g'}$	0.1	0.24	0.24	0.51	0.51	1.0	M $\Omega$
Output voltage ( $d_{tot} = 5\%$ )	$V_o$	12	17	16	20	18	23	V <sub>RMS</sub>
Voltage gain ( $V_o = 2$ V <sub>RMS</sub> )	$V_o/V_i$	31	33	32	33	31	32	
Anode voltage	$V_{ba}$	300	300	300	300	300	300	V
Anode resistor	$R_a$	0.1	0.1	0.24	0.24	0.51	0.51	M $\Omega$
Cathode resistor	$R_k$	1000	1200	3300	2800	4900	6000	$\Omega$
Grid resistor of next stage	$R_{g'}$	0.1	0.24	0.24	0.51	0.51	1.0	M $\Omega$
Output voltage ( $d_{tot} = 5\%$ )	$V_o$	22	30	28	35	31	38	V <sub>RMS</sub>
Voltage gain ( $V_o = 2$ V <sub>RMS</sub> )	$V_o/V_i$	32	33	34	33	33	33	



## OPERATING CHARACTERISTICS (continued)

Resistance of voltage source 100 k $\Omega$ 

Anode supply voltage	$V_{ba}$	90	90	90	90	90	90	V
Anode resistor	$R_a$	0.1	0.1	0.24	0.24	0.51	0.51	M $\Omega$
Cathode resistor	$R_k$	2000	2400	4700	5300	9300	11000	$\Omega$
Grid resistor of next stage	$R_{g'}$	0.1	0.24	0.24	0.51	0.51	1.0	M $\Omega$
Output voltage ( $d_{tot} = 5\%$ )	$V_o$	9.9	13	12	15	13	16	V <sub>RMS</sub>
Voltage gain ( $V_o = 2 V_{RMS}$ )	$V_o/V_i$	25	27	27	28	27	28	
Anode supply voltage	$V_{ba}$	180	180	180	180	180	180	V
Anode resistor	$R_a$	0.1	0.1	0.24	0.24	0.51	0.51	M $\Omega$
Cathode resistor	$R_k$	1200	1400	2900	3600	6000	7100	$\Omega$
Grid resistor of next stage	$R_{g'}$	0.1	0.24	0.24	0.51	0.51	1.0	M $\Omega$
Output voltage ( $d_{tot} = 5\%$ )	$V_o$	17	28	25	31	27	33	V <sub>RMS</sub>
Voltage gain ( $V_o = 2 V_{RMS}$ )	$V_o/V_i$	31	33	32	33	31	32	
Anode supply voltage	$V_{ba}$	300	300	300	300	300	300	V
Anode resistor	$R_a$	0.1	0.1	0.24	0.24	0.51	0.51	M $\Omega$
Cathode resistor	$R_k$	900	1200	2300	2900	5000	6400	$\Omega$
Grid resistor of next stage	$R_{g'}$	0.1	0.24	0.24	0.51	0.51	1.0	M $\Omega$
Output voltage ( $d_{tot} = 5\%$ )	$V_o$	35	47	42	52	45	55	V <sub>RMS</sub>
Voltage gain ( $V_o = 2 V_{RMS}$ )	$V_o/V_i$	33	33	34	34	33	34	

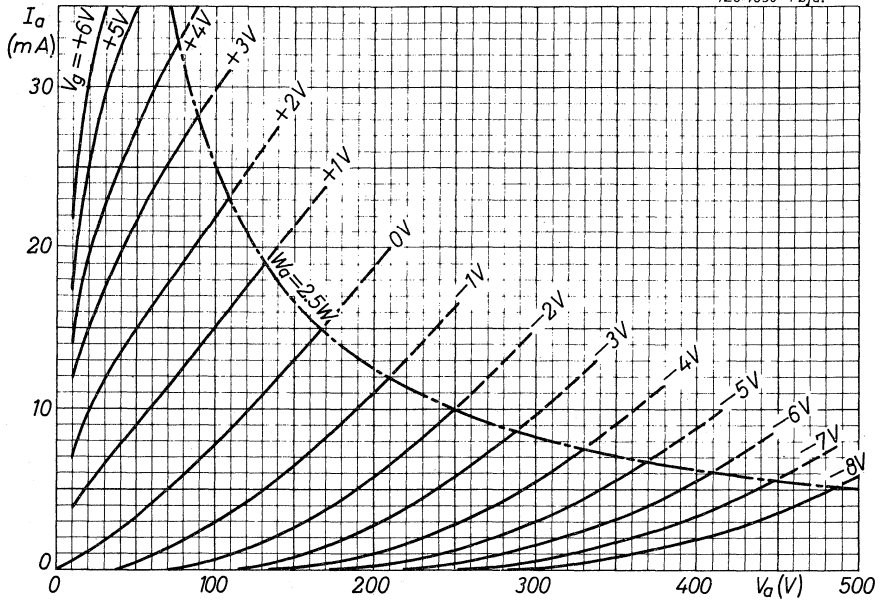

## S.Q. TUBE

Pentode designed for use in telephone equipment.

### QUICK REFERENCE DATA

Life test	10 000 hours	
Low interface resistance		
Base	Noval	
Heating	Indirect A.C. or D.C. Series or parallel supply	
Heater voltage	$V_f$	18 V
Heater current	$I_f$	100 mA
Anode current	$I_a$	10 mA
Mutual conductance	S	9 mA/V

### DIMENSIONS AND CONNECTIONS

Dimensions in mm

Base: Noval

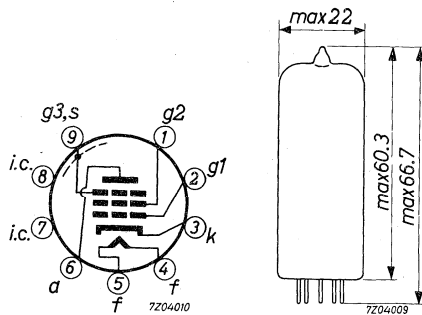

## CHARACTERISTICS

- Column I Nominal value or setting of the tube  
 II Range values for equipment design: Initial spread  
 III Range values for equipment design: End of life

		I	II	III	
Heater voltage	$V_f$	18			V
Heater current	$I_f$	100	95 - 105		mA
Anode voltage	$V_a$	210			V
Grid No.3 voltage	$V_{g3}$	0			V
Grid No.2 voltage	$V_{g2}$	120			V
Cathode resistor	$R_k$	165			$\Omega$
Anode current	$I_a$	10	8.7 - 11.3	min. 7	mA
Grid No.2 current	$I_{g2}$	2.1	1.7 - 2.5	min. 1.25	mA
Mutual conductance	S	9	7.8 - 10.2	min. 6.4	mA/V
Internal resistance	$R_i$	0.5	min. 0.3		M $\Omega$
Amplification factor	$\mu_{g2g1}$	38			
Equivalent noise resistance					
R.F.	$R_{eq}$	750	max. 1000		$\Omega$
A.F. (0 - 10 kHz)	$R_{eq}$		max. 36		k $\Omega$
Negative grid current	$-I_{g1}$		max. 0.5	max. 1.0	$\mu$ A
<u>Cut-off voltage</u>	$-V_g$		max. 5.25		V
Anode voltage	$V_a$	210			V
Grid No.3 voltage	$V_{g3}$	0			V
Grid No.2 voltage	$V_{g2}$	120			V
Anode current	$I_a$	0.5			mA
<u>Hum voltage</u>	$V_{g1}$		max. 0.5		mV <sub>RMS</sub>
Grid No.1 resistor $R_{g1} = 0.5$ M $\Omega$					
<u>Leakage current between cathode and heater</u>	$I_{kf}$		max. 20		$\mu$ A
Voltage between cathode and heater $V_{kf} = 100$ V					

**CAPACITANCES**

Anode to grid No.2, grid No.3,  
cathode and heater

	I	II	
$C_{a/g_2g_3kfs}$	3.5	max. 4.1	pF

Grid No.1 to grid No.2, grid No.3,  
cathode, heater and screen

$C_{g_1/g_2g_3kfs}$	8.0	max. 8.7	pF
---------------------	-----	----------	----

Anode to grid No.1

$C_{ag_1}$		max. 0.015	pF
------------	--	------------	----

Grid No.1 to heater

$C_{g_{1f}}$		max. 0.15	pF
--------------	--	-----------	----

Cathode to heater

$C_{kf}$	4		pF
----------	---	--	----

Grid No.1 to grid No.2, grid No.3,  
cathode, heater and screen

$C_{g_1/g_2g_3kfs}$	11.3		pF
---------------------	------	--	----

Cathode current = 12.1 mA

Radiation capacitance:

Anode to surrounding box, inner  
diam. 52 mm, height 98 mm

$C_{ra}$		max. 0.025	pF
----------	--	------------	----

Grid No.1 to surrounding box, inner  
diam. 52 mm, height 98 mm

$C_{rg_1}$		max. 0.025	pF
------------	--	------------	----

**LIFE**

Production samples are tested to be within the end of life values (column III) during 10 000 hours.

**LIMITING VALUES** Design centre rating system

Anode voltage	$V_{a_0}$	max. 550	V
	$V_a$	max. 210	V
Anode dissipation	$W_a$	max. 2.1	W
Grid No.2 voltage	$V_{g_{2_0}}$	max. 550	V
	$V_{g_2}$	max. 210	V
Grid No.2 dissipation	$W_{g_2}$	max. 0.35	W
Cathode current	$I_k$	max. 16	mA
Grid No.1 resistor (automatic bias)	$R_{g_1}$	max. 1	MΩ
Voltage between cathode and heater	$V_{kf}$	max. 100	V
Bulb temperature	$t_{bulb}$	max. 170	°C

**LIMITING VALUES** (continued)

Heater voltage: The average heater voltage should be 18 V.

Variations of the heater voltage exceeding the range of 17.1 to 18.9 V will shorten the tube life.

The tolerance of heater current (column II) should be taken into account.

**OPERATING CHARACTERISTICS**Output tube class A

Anode voltage	$V_a$	120		210		V		
Grid No.3 voltage	$V_{g_3}$	0		0		V		
Grid No.2 supply voltage	$V_{bg_2}$	120		120		V		
Grid No.2 resistor	$R_{g_2}$	5.6		5.6		$k\Omega$		
Cathode resistor	$R_k$	180		180		$\Omega$		
Anode current	$I_a$	8.3		8.3		mA		
Grid No.2 current	$I_{g_2}$	1.7		1.7		mA		
Mutual conductance	$S$	8.2		8.2		mA/V		
Internal resistance	$R_i$	0.42		0.44		$M\Omega$		
Load resistance	$R_{a\sim}$	10		20		$k\Omega$		
Output power	$W_o$	340	400	50	660	870	50	mW
Input voltage	$V_i$	1.1	-	0.35	1.1	-	0.25	$V_{RMS}$
Total distortion	$d_{tot}$	10	-	-	10	-	-	%
Grid No.1 current	$+I_g$	-	0.3	-	-	0.3	-	$\mu A$
Grid No.1 resistor	$R_{g_1}$	-	0.33	-	-	0.33	-	$M\Omega$

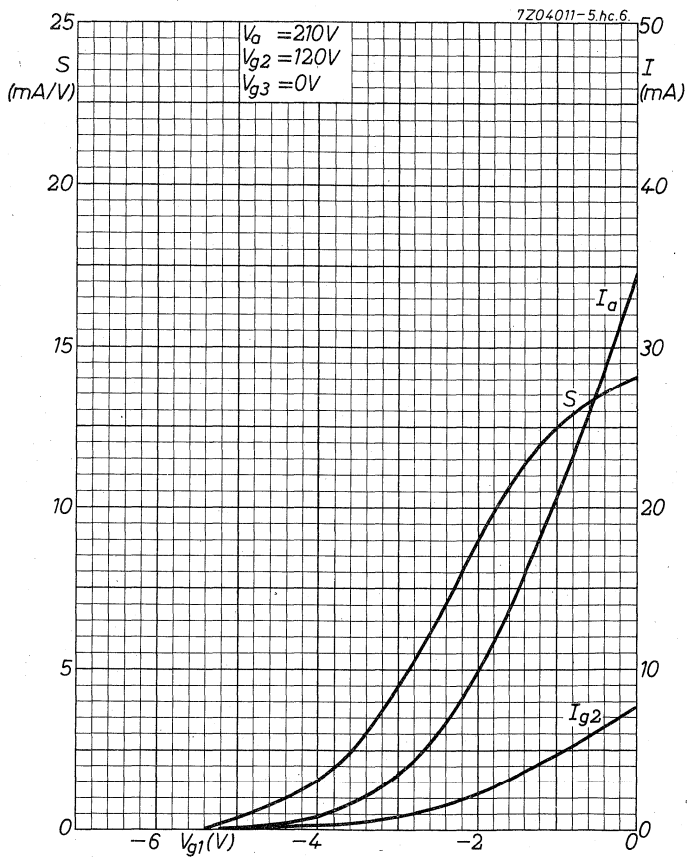

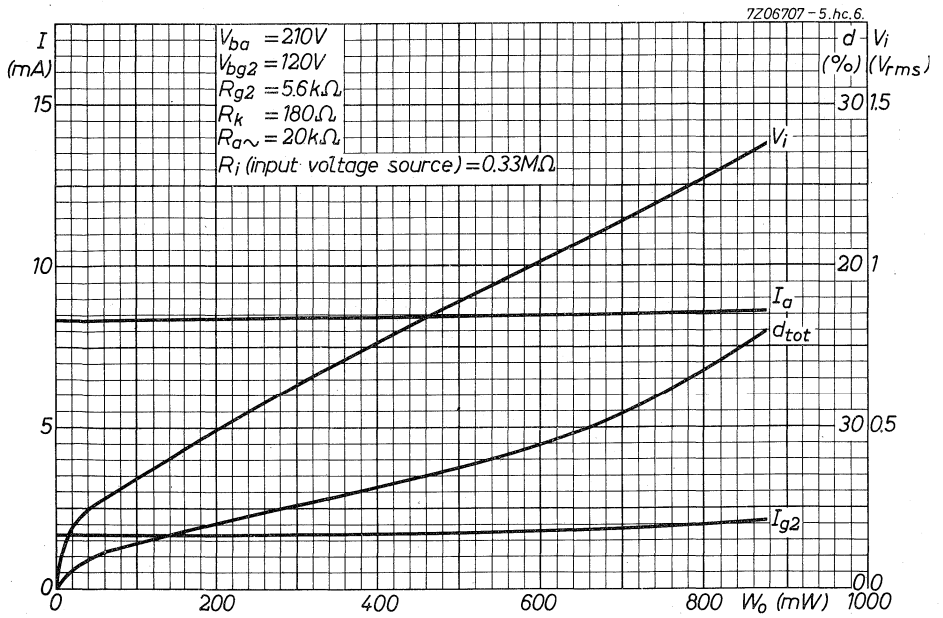
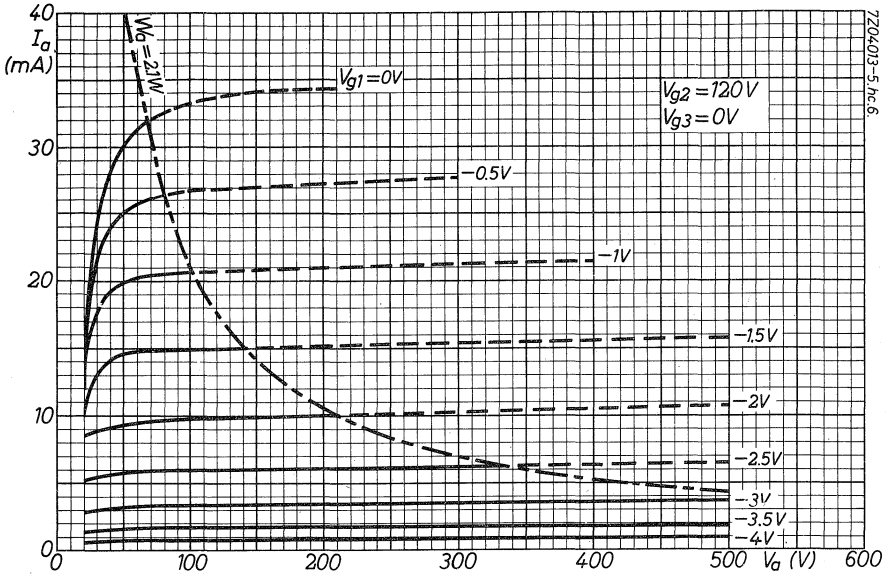



## S.Q. TUBE

Output pentode designed for use in telephone equipment.

QUICK REFERENCE DATA	
Life test	10000 hours
Base	Noval
Heating	Indirect A.C. or D.C. Series or parallel supply
Heater voltage	$V_f$ 18 V
Heater current	$I_f$ 130 mA
Anode current	$I_a$ 20 mA
Output power, Class A	$W_o$ 1 W

### DIMENSIONS AND CONNECTIONS

Dimensions in mm

Base: Noval

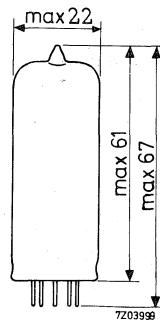
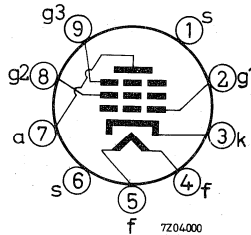

## CHARACTERISTICS

Column I Nominal value or setting of the tube

II Range values for equipment design: Initial spread

III Range values for equipment design: End of life

		I	II	III	
Heater voltage	$V_f$	18			V
Heater current	$I_f$	130	123 - 137		mA
Anode voltage	$V_a$	210			V
Grid No.3 voltage	$V_{g_3}$	0			V
Grid No.2 voltage	$V_{g_2}$	210			V
Cathode resistor	$R_k$	120			$\Omega$
Anode current	$I_a$	20	17 - 23	min. 13.5	mA
Grid No.2 current	$I_{g_2}$	5.3	4.1 - 6.5	min. 3.1	mA
Mutual conductance	S	11	9.5 - 12.5	min. 7.8	mA/V
Internal resistance	$R_i$	0.3	min. 0.2		$M\Omega$
Output power	$W_o$	1.0	min. 0.7		W
Load resistance $R_{a\sim} = 15 k\Omega$					
Total distortion $d_{tot} = 5\%$					
Total distortion at $W_o = 0.1 W$	$d_{tot}$	1.2	max. 2		%
Amplification factor	$\mu_{g_2g_1}$	36			
Equivalent noise resistance (R.F.)	$R_{eq}$	1.2			$k\Omega$
<u>Negative grid current</u>	$-I_{g_1}$		max. 0.5	max. 1.0	$\mu A$
<u>Cut-off voltage</u>	$-V_{g_1}$		max. 8.5		V
Anode current	$I_a$	0.5			mA
<u>Hum voltage</u>	$V_{g_1}$		max. 0.2		$mV_{RMS}$
$R_{g_1} = 0.5 M\Omega$					
Heater centre earthed					
<u>Insulation resistance between two electrodes</u>	$R_{ins}$		min. 100		$M\Omega$

**CHARACTERISTICS** (continued)Leakage current between  
cathode and heaterVoltage between cathode and  
heater  $V_{kf} = 120$  V

Cathode heating time

Cathode cooling time

**CAPACITANCES**Anode to grid No.2, grid No.3,  
cathode, heater and screenGrid No.1 to grid No.2, grid No.3,  
cathode, heater and screenGrid No.1 to grid No.2, grid No.3,  
cathode, heater and screenCathode current  $I_k = 25$  mA

Anode to grid No.1

Grid No.1 to heater

Cathode to heater

Radiation capacitance: Anode to  
surrounding box, inner dia. 52 mm,  
height 98 mmRadiation capacitance: Grid No.1 to  
surrounding box, inner dia. 52 mm,  
height 98 mm

	I	II	
$I_{kf}$		max. 24	$\mu$ A
	16	max. 22	sec
	15	min. 7	sec
$C_{a/g_2g_3kfs}$	6.5	5.8 - 7.2	pF
$C_{g_1/g_2g_3kfs}$	11.2	10 - 12.4	pF
$C_{g_1/g_2g_3kfs}$	14.3		pF
$C_{ag_1}$		max.0.02	pF
$C_{g_1f}$		max. 0.2	pF
$C_{kf}$	4.2		pF
$C_{ra}$		max.0.06	pF
$C_{rg_1}$		max.0.12	pF

**LIFE**Production samples are tested to be within the end of life values (column III)  
during 10 000 hours.

**LIMITING VALUES** (Design centre rating system)

Anode voltage	$V_{a_0}$	max. 550 V
	$V_a$	max. 210 V
Anode dissipation	$W_a$	max. 4.5 W
Grid No.2 voltage	$V_{g_{2_0}}$	max. 550 V
	$V_{g_2}$	max. 210 V
Grid No.2 dissipation	$W_{g_2}$	max. 1.2 W
Cathode current	$I_k$	max. 30 mA
Voltage between cathode and heater	$V_{kf}$	max. 120 V
Bulb temperature	$t_{bulb}$	max. 170 °C
Grid resistor, automatic bias	$R_{g_1}$	max. 0.5 MΩ
fixed bias	$R_{g_1}$	max. 0.25 MΩ

**OPERATING CHARACTERISTICS**As pre-amplifier

Anode voltage	$V_a$	210 V
Grid No.3 voltage	$V_{g_3}$	0 V
Grid No.2 voltage	$V_{g_2}$	210 V
Cathode resistor	$R_k$	180 Ω
Anode resistance	$R_{a\sim}$	20 kΩ
Anode current	$I_a$	15 mA
Grid No.2 current	$I_{g_2}$	4 mA
Mutual conductance	$S$	10 mA/V
Internal resistance	$R_i$	0.4 MΩ
Voltage gain	$g$	5.15 Neper

OPERATING CHARACTERISTICS (continued)

As output tube class A

Anode voltage	$V_a$	210 V
Grid No.3 voltage	$V_{g3}$	0 V
Grid No.2 voltage	$V_{g2}$	210 V
Cathode resistor	$R_k$	120 $\Omega$
Anode current	$I_a$	20 mA
Grid No.2 current	$I_{g2}$	5.3 mA
Mutual conductance	$S$	11 mA/V
Internal resistance	$R_i$	0.3 $M\Omega$
Anode resistance	$R_{a\sim}$	15 $k\Omega$
Input voltage	$V_i$	0.95 $V_{RMS}$
Output power	$W_o$	1 W
Total distortion	$d_{tot}$	5 %

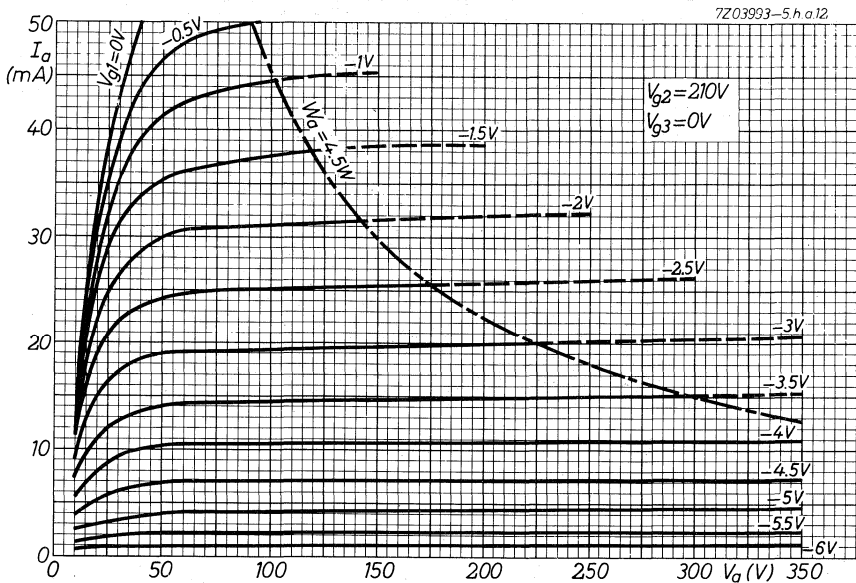

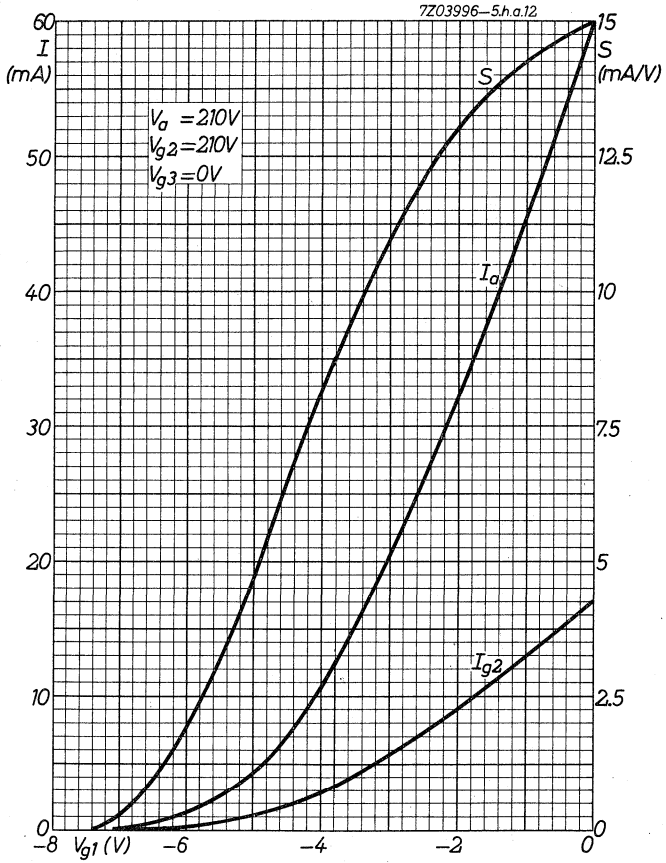

## Miscellaneous devices







OBSOLESCENT TYPE ←

**TH71 TH73  
TH75**

## THERMOCOUPLES

Indirectly heated thermocouples in subminiature construction.

### DIMENSIONS AND CONNECTIONS

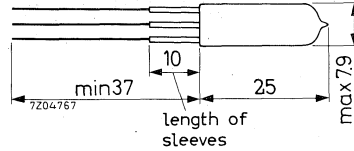
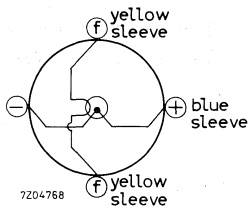

### CHARACTERISTICS AND LIMITING VALUES (Absolute max. rating system)

		TH71	TH73	TH75	
Heater current	$I_f$	0 to 15	0 to 75	0 to 300	mA
Heater current <sup>1)</sup>	$I_f$	0 to 5	0 to 20	0 to 100	mA
Heater current at $E = 12$ mV	$I_f$	10	40	200	mA
Heater current ( $T = \text{max. } 1 \text{ m}$ )	$I_f$	max.	20	100	350 mA
Heater resistance	$R_f$	68	7.0	1.2	$\Omega$
Resistance of thermocouple	$R_{TH}$	6.0	3.5	3.5	$\Omega$
Response time <sup>2)</sup>	$T$	10	10	10	s
at heater current $I_f =$		10	40	200	mA
Heater to thermocouple voltage	$V_f/TH$	max.	100	100	100 V

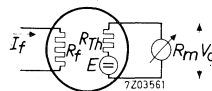
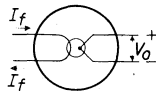

- 1) In approximately this range  $V_0$  is proportional to the square of  $I_f$
- 2) Time between the moment of switching on of  $I_f$  and the moment of reaching max. voltage (See page 4).

**REMARK**

The electrical characteristics of the types TH71, TH73 and TH75 are identical to those of the types TH1, TH3, TH5 and TH91, TH93 and TH95 respectively and therefore can be used as replacement for these types.

**GENERAL INFORMATION**

The "hot" weld of the thermocouple consists of an iron constantan junction.

The "cold" welds are iron to copper and constantan to copper junctions inside the vacuum envelope.

The tube has copper leads.

The measuring results are practically independent of the ambient temperature of the tube so that no corrections need to be made for the temperature of the "cold" weld.

**TH71 TH73  
TH75**

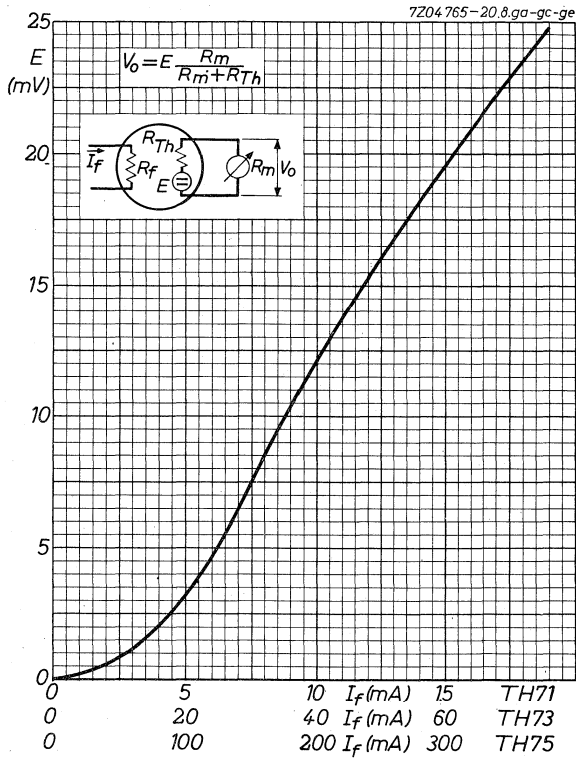

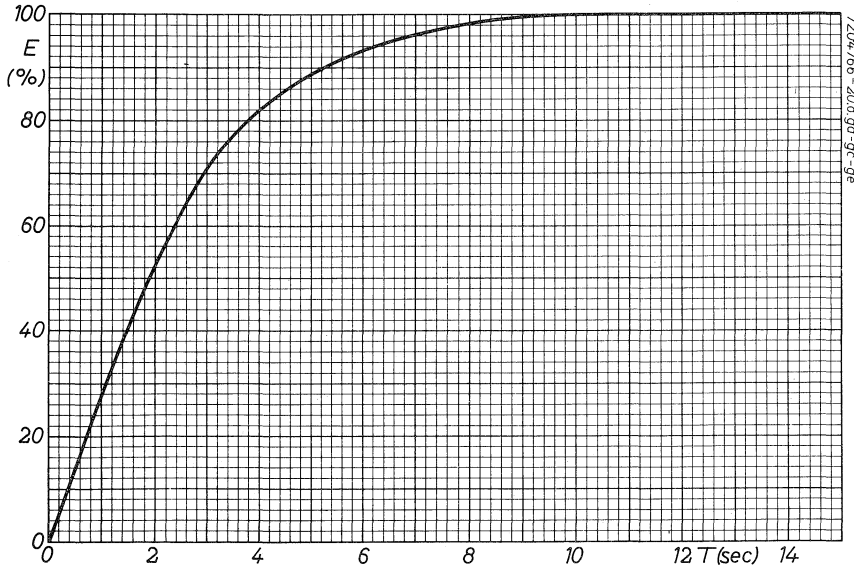

## INDEX OF TYPENUMBERS

Type no.	Section	Type no.	Section	Type no.	Section
C3m	SQ	EC91	SQ	6922	see E88CC
D3a	SQ	EC1000	SQ	6977	see DM160
DM160	SQ	EC8010	SQ	7062	see E180CC
E55L	SQ	ECC2000	SQ	7119	see E182CC
E80CC	SQ	TH71, 73, 75	M	7308	see E188CC
E80CF	SQ	6Q4	see EC80	7320	see E84L
E80F	SQ	6R4	see EC81	7534	see E130L
E80L	SQ	12AX7S	SQ	7643	see E80CF
E81L	SQ	5639	SQ	7721	see D3a
E82CC	SQ	5654	SQ	7722	see E280F
E83CC	SQ	5718	SQ	7737	see E186F
E83F	SQ	5725	SQ	7788	see E810F
E84L	SQ	5726	SQ	8223	see E288CC
E86C	SQ	5840	SQ	8233	see E55L
E88C	SQ	5899	SQ	8254	see EC1000
E88CC	SQ	5902	SQ	8255	see E88CC
E90CC	SQ	5920	see E90CC	18042	SQ
E130L	SQ	6021	SQ	18045	SQ
E180CC	SQ	6080	SQ		
E180F	SQ	6084	see E80F		
E182CC	SQ	6085	see E80CC		
E186F	SQ	6086	see 18042		
E188CC	SQ	6111	SQ		
E280F	SQ	6189	SQ		
E282F	SQ	6201	SQ		
E283CC	SQ	6227	see E81L		
E288CC	SQ	6681	see E83CC		
E810F	SQ	6686	see E81L		
EC80	SQ	6688	see E180F		
EC81	SQ	6689	see E83F		

SQ = Special Quality tubes

M = Miscellaneous



---

Special Quality tubes

---

Miscellaneous devices

---

Index

---



